

KM-Tugs (KMT-T15) 1500kg 1565x723x1160mm

This smart tow tractor with its 1500kg capacity makes it a simple machine to tow, trailers, boats, light planes, cars and caravans. Predominantly used in airports, warehouses and other facilities, this tugger is great for compact and condensed areas when open space is limited. It not only has the ability to pull loads, but push them as well without extreme stress or strain on the user's body. Easy to reach button controls are centrally located on steering handle. Unit includes batteries, battery charger and battery level gauge.

Features

- Durable steel construction.
- Large tires for increased traction.
- DC operated for consistent power supply.
- Powder coated surface for long term toughness.
- Easy to connect to the adjustable tow bar or front towing hitch.



Specifications

Model		KMT-T15
Capacity	(kg)	1500
Drive Bridge	(v/w)	DC24V/800W
Front Wheel	(mm)	310x115 pneumatic
Rear Wheel	(mm)	200x50
Support Wheel		-----
Battery	(v/Ah)	2*12V/70Ah
Charger	(v/A)	24V/10A
Traction Speed	(km/h)	0-5km/h
Turning R.	(mm)	1450
Overall Size	(mm)	1565x723x1160 (940)

Visit www.mitaco.com.au for more photos and details



Mitaco has national sales and distribution capabilities, our sales office and warehouse is located in Brisbane. Large inventory holdings enable fast-track dispatch of stock orders. This combined with an easy to use online ordering system makes the delivery of stocked products simple, fast and reliable.

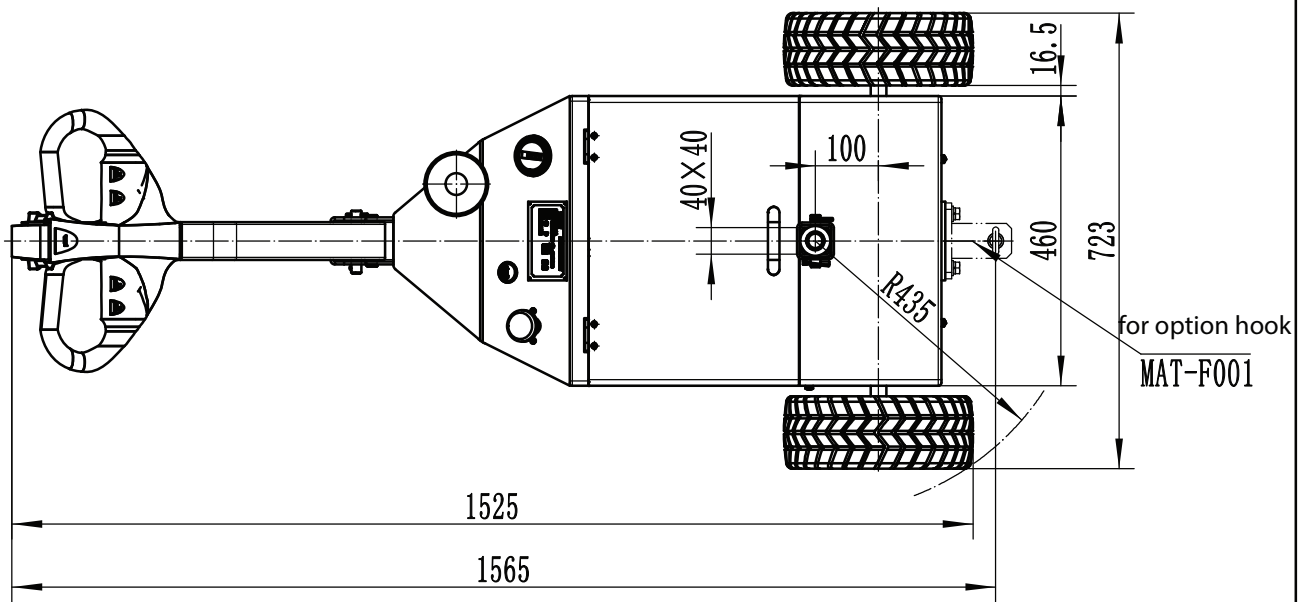
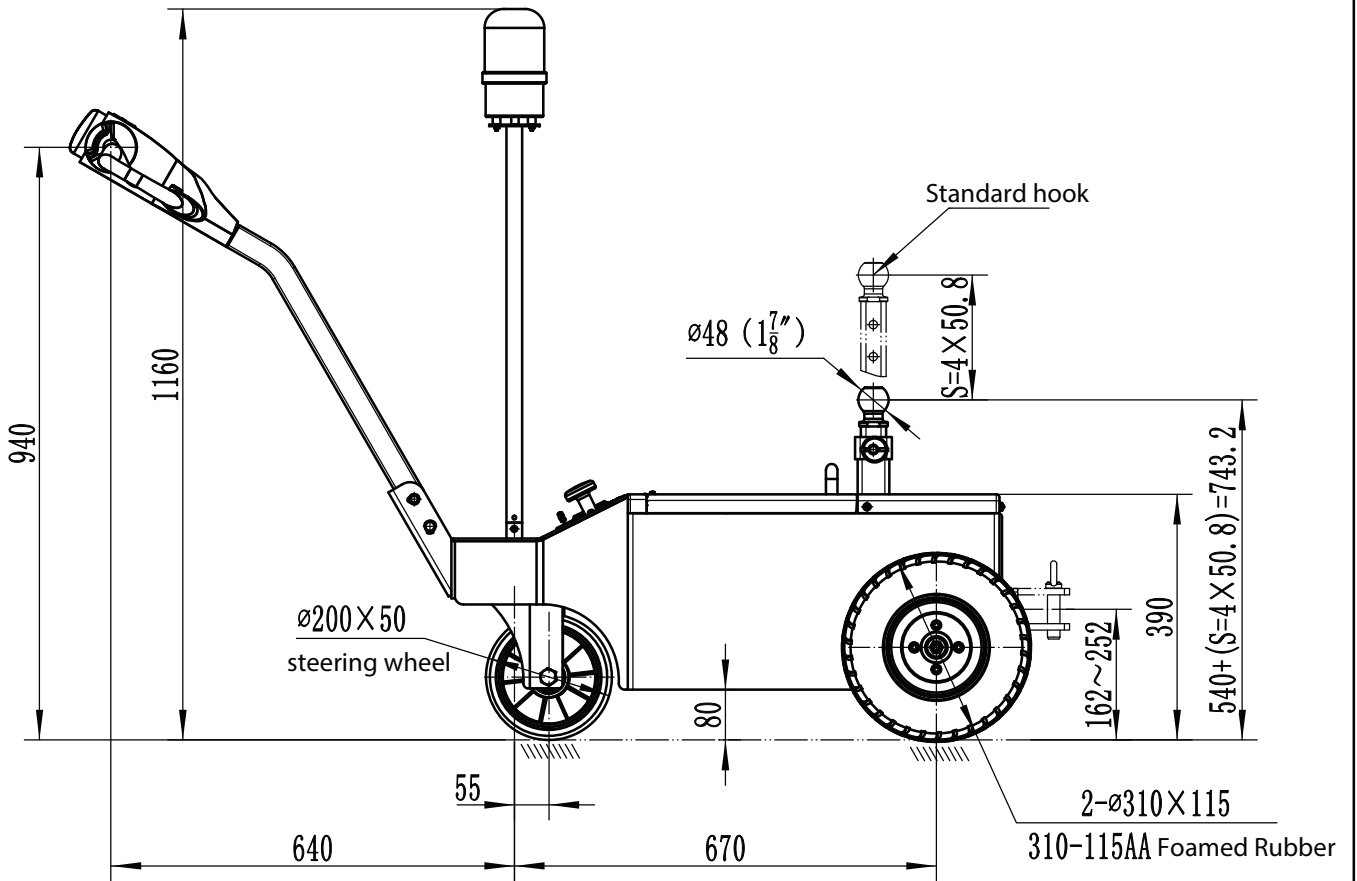

Specification:

1. Traction Cap. 1500kg
2. Drive bridge: DC24V/800W
3. Battery: 2*12V/70Ah
4. Charger: 24V/15A
5. Traction speed: 0-5km/h

Model:		KMT-T15	
Descrip:			
Design:		Date:	

Customer: