

Model 1620



## Active hoist

A quick solution for toilet transfers



- For a quick transfer from seat to seat
- Highly mobile and compact
- Exchangeable battery box with integrated charger
- Adjustable knee support
- Emergency operation
- Safety belt for lower legs



Lift & Care systems for people with reduced mobility

[www.handimove.com](http://www.handimove.com)

# Active hoist

## ● Dimensions and specifications

A.....	Max. height .....	1690 mm
B.....	Min. height .....	1070 mm
C.....	Mast Height .....	740 mm
D.....	Base height .....	110 mm
E.....	Max. base width .....	920 mm
F.....	Min. base width .....	635 mm
G.....	Base length .....	990 mm
H.....	Caster height .....	100 mm

Safe working load .....	150 kg
Batteries .....	2 x 12 volt 2,9 ah rechargeable
Charger - input .....	220/230 V AC
Charger -output .....	27.4/29.0 V DC
Weight .....	43.5 kg
Emergency down .....	mechanical
Number of lifts with fully charged batteries .....	40

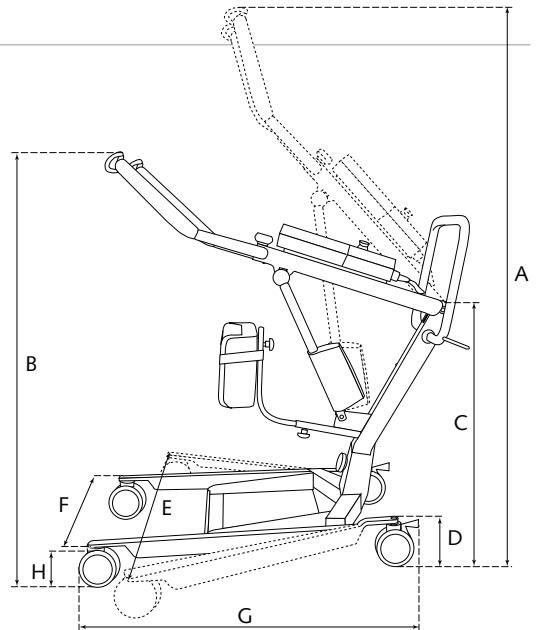

## ● Active sling

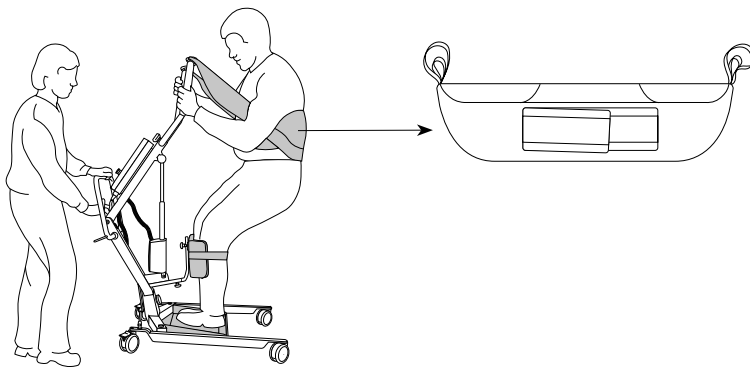

## ● Control box and removable battery box

A.....	Removable batterybox
B.....	Emergency switch
C.....	Battery status indicator (LCD)
D.....	Electrical emergency controls
E.....	Charging procedure indicator led
F.....	Charger current indicator led

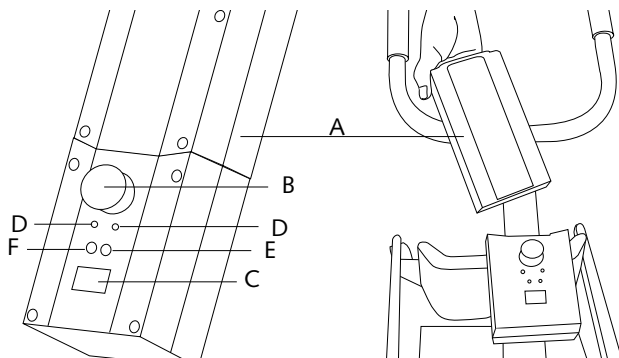

For free demonstration or further information

