

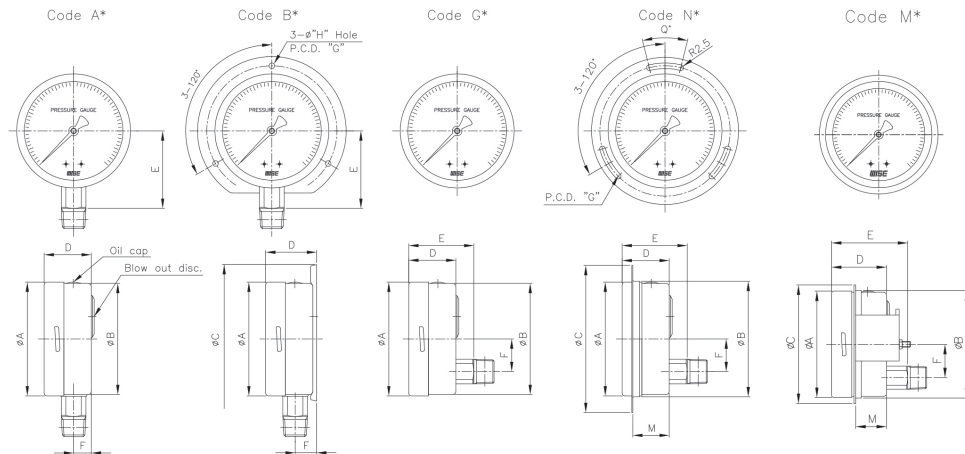

100mm Industrial Quality Pressure Gauge

Case and bezel material:	304 Stainless Steel Liquid Fillable
Connection:	Copper alloy 2.0460
Bourdon tube material:	<10,000 kPa = Copper alloy 2.0460, >10,000 kPa = 316 Stainless Steel
Working temperature:	Ambient = -20~65°C, Process = + 60°C
Dial:	Aluminium, Black print on White Background
Ranges:	-100~0 kPa to 0~100,000 kPa
Connection:	3/8" BSPT Lower Mount & Lower Back Mount
Window:	Laminated Safety Glass
Blowout Protection:	Rubber Disc on the Back
Over Range Protection:	130% of Full Scale
Movement:	304 Stainless Steel
Pointer:	Micro-adjustable
Accuracy:	1.0% of Full Scale
Protection Rating:	IP65



Dimensions in mm

Type	Available Code	A	B	C	D	E	F	G	M	Q
P 253 100mm Dial	A*	101.3			50	83	16			
	B*	101.3		133	54.4	83	19.4	116		
	G*	101.3	99		50	83	29			
	N*	101.3	103.1	131	50	83	29	116	45	28
	M*	101.3	101	107.5	50	65	29		29.5	

Range (in kPa)	Lower Mount Code A *	Lower Back Mount	Range (in kPa)	Lower Mount Code A *	Lower Back Mount Code M *	Accessories	
-100-0	2702000	On request	0-1600	2702022	On request	Back Flange	
-100/+150	On request	On request	0-2500	2702024	2702341	P/N: 2701997	
-100/+300	2702002	On request	0-4000	2702026	2702342		
-100/+500	On request	On request	0-6000	On request	2702343	Internal Restrictor	
-100/+900	2702003	On request	0-8000	On request	On request		
-100/+1500	On request	On request	0-10000	On request	2702344	Glycerine Filling	
0-100	2702010	On request	0-16000	2702034	On request	P/N: 2701999	
0-160	2702012	On request	0-25000	On request	On request		
0-250	2702014	On request	0-40000	On request	On request	Polycarbonate Lens	
0-400	2702016	On request	0-60000	On request	On request	P/N: 2701992	
0-600	2702017	On request	0-80000	On request	On request		
0-800	2702018	On request	0-100000	On request	On request		
0-1000	2702020	On request					
Weight gms			Add 320 gms for glycerine filling				

Revision: 0719

The data provided above is for information purposes only and no warranty of accuracy or reliability is given.
Ross Brown Sales Pty Limited reserves the right to change or modify this data without prior notice.