



# PEDESTRIAN TRACTOR MP13

## CAPACITY 1300 KG | SERIES 8904

### Safety

The MP13 eliminates the physical effort which causes physical stress and strain to users. The position of the tiller places the operator in a safe, yet comfortable, working distance from the truck. The efficient braking systems ensure inherent safety. The MP13 features an effective parking brake to hold the truck safely on slopes or on truck tail lifts.

### Performance

With the MP13 moving trolleys, roll cages, or shopping carts has never been so easy. Equipped with a 0.4 kW drive motor, the MP13 offers a highly cost-effective and productive solution for short distance transfer duties of loads up to 1300 kg. Its compactness guarantees maximum maneuverability when operating in a busy area or in confined spaces.

### Comfort

The dual butterfly lever on the ergonomic tiller head ensures precise traction control with either hand. The inclination of the tiller can be

easily and conveniently adjusted to suit every operator's preferences. A built-in charger enables the battery to be charged at any convenient power point for optimum uptime.

### Reliability

The durable drive unit of the MP13 delivers consistent high performance and reliability. It is equipped with a maintenance-free gel battery. The battery discharge indicator, with an operating hour meter, informs you at any time about the charging status of the battery.

### Productivity

The DC drive motor optimizes uptime ratios between routine service periods and reduces service costs, while a reliable, energy-efficient controller delivers smooth handling performance. Fast and easy access to all internal components ensures service tasks are completed with a minimum of delay.

# TECHNICAL DATA

## ACCORDING TO VDI 2198

Characteristics	1.1	Manufacturer		Linde
	1.2	Model designation		<b>MP13</b>
	1.3	Power unit		Battery
	1.4	Operation		Pedestrian
	1.5	Rated capacity	Q (t)	1.3
	1.7	Rated drawbar pull	F (N)	200
	1.9	Wheelbase	y (mm)	315
Weight	2.1	Service weight (include battery)	kg	98
	2.2	Axle loading, laden driving side/loading side	kg	98/0
	2.3	Axle loading without load, (front) drive/(rear) load	kg	78/20
Wheels and types	3.1	Tyre, (front) drive/(rear) load		Pneumatic
	3.2	Tyre size, (front)drive wheel	mm	2 x Ø250 x 85
	3.3	Tyre size, (rear)load wheel	mm	2 x Ø75 x 32
	3.5	Wheels, number (front)drive/(rear)load (x=drive wheels)		2x/2
	3.6	Track width, (front)drive	b <sub>10</sub> (mm)	428
	3.7	Track width, (rear)load wheel	b <sub>11</sub> (mm)	217
	Dimensions	4.9	Height drawbar in driving position min./max.	h <sub>14</sub> (mm)
4.12		Tow coupling height	h <sub>10</sub> (mm)	120 - 280
4.17		Rear overhang	l <sub>5</sub> (mm)	430
4.19		Overall length	l <sub>1</sub> (mm)	1284/1344/1374
4.21		Overall width	b <sub>1</sub> /b <sub>2</sub> (mm)	520
4.32		Ground clearance, center of wheelbase	m <sub>2</sub> (mm)	30
4.35		Turning radius	W <sub>a</sub> (mm)	890/940/980
Performance	5.1	Travel speed, with/without load	km/h	4/4.5
	5.5	Drawbar pull (60 minutes rating)	N	200
	5.6	Max. drawbar pull (5 minutes rating)	N	650
	5.8	Maximum gradeability, with/without load	%	3/16
	5.10	Service brake		Electromagnetic
Drive	6.1	Drive motor rating S <sub>2</sub> 60 min	kW	0.4
	6.3	The maximum allowed size battery	mm	195/165/175
	6.4	Battery voltage/ rated capacity K20	(V)/(Ah)	24/50
	6.5	Battery weight (+5%)	kg	2x14
	6.6	Energy consumption acc. to VDI cycle	kWh/h at number of cycles	
Others	8.1	Type of drive control		DC
	10.5	Steering type		Mechanical
	10.7	Noise level at the driver's ear	dB(A)	<50

# STANDARD EQUIPMENT / OPTIONAL EQUIPMENT

## STANDARD EQUIPMENT

Pneumatic drive wheel

Front hook

4/4.5 km/h travel speed (w/o load)

Built-in charger

Gel battery 24V 50Ah

Display: hour meter, battery discharge indicator

Automatic parking brake

Belly switch on tiller head

Key switch

Plug: EU type

## OPTIONAL EQUIPMENT

Various towing couplings

Plug interlock (compulsory for UK)

Plug: UK type

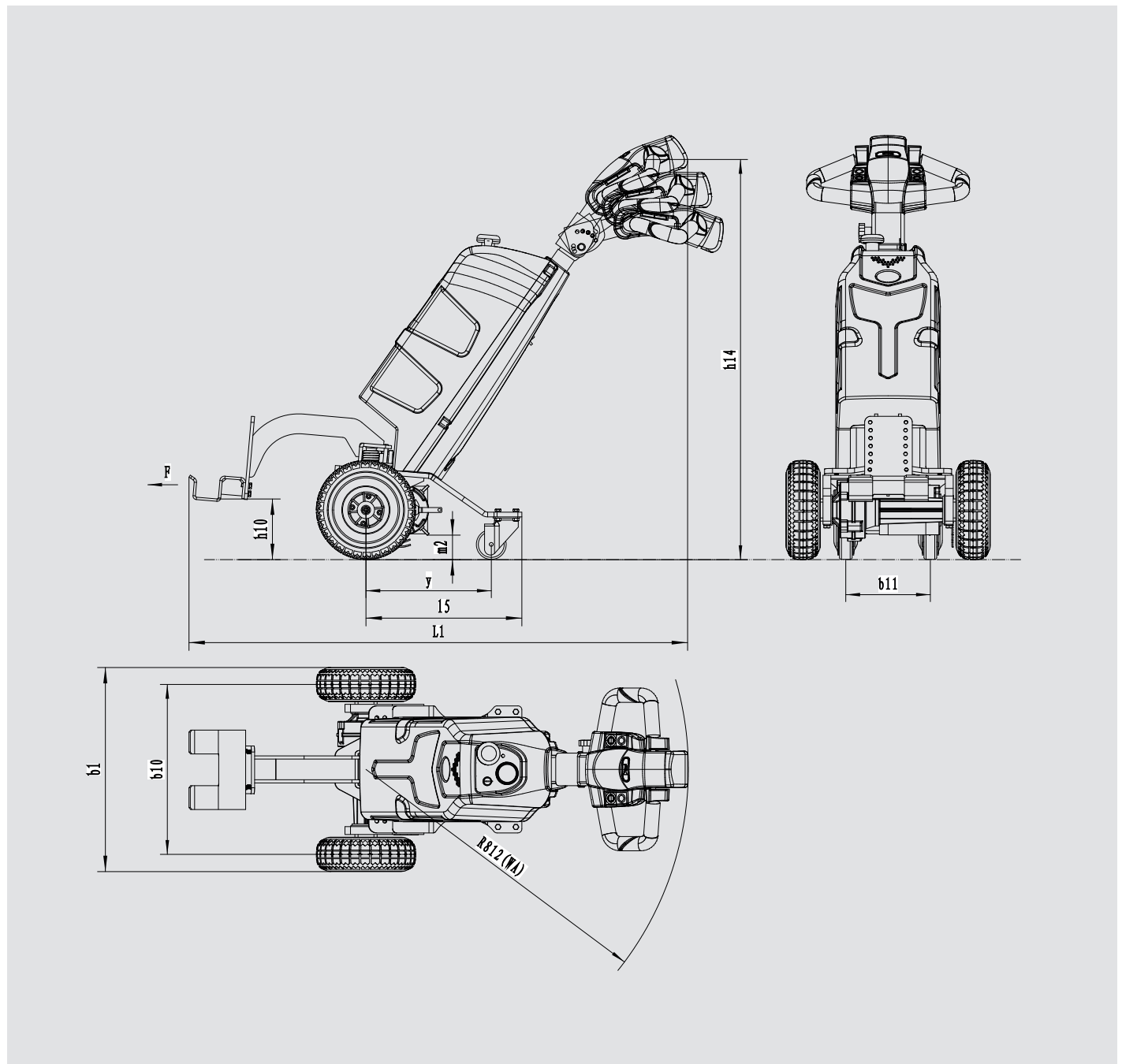

# FEATURES

## Drive unit

- DC drive motor
- Reliable, energy efficient electronic controller
- Adjustable parameters: travel speed and acceleration

## Multifunctional display

- Reliable and precise battery discharge indicator
- Operating hour meter
- Faults code indication

## Braking system

- Automatic deceleration when butterfly button is released
- Parking brake applies automatically when tiller arm is released
- Proofed emergency button
- Key switch

## Energy

- Built-in gel battery
- Maintenance-free battery: 2 x 12V 50Ah
- Autonomy up to 3h



## Tiller and tiller head

- Adjustable tiller height
- Traction controls grouped on ergonomic tiller head
- Dual butterfly control can be levered with either hand
- Belly switch on tiller head stops truck when actuated

## Built-in charger

- Built-in charger enables the battery to be charged at any convenient power point during occasional breaks
- Plug interlock for more safety

## Towing couplings

- Easy coupling and decoupling
- Coupling is always in an excellent view of operator
- Additional various coupling devices

Linde Material Handling

*Linde*

Linde Material Handling | 5 Distillers Place | Huntingwood NSW 2148  
Phone 1300 135 463 | [www.lindemh.com.au](http://www.lindemh.com.au)