

# SureSWEEP

---

## Operating manual (Translation of the original version)



**ST1000**

---

---

## Table of Contents

1.1	Usage conformant with intended purpose .....	3
3.1	Initial Startup .....	7
3.1.1	Unpacking and mounting.....	7
4.1.1	Driving.....	9
4.2	Sweeping operation .....	10
4.2.1	Safety Information .....	10
4.2.2	Operatting the Sweeping Rollers.....	11
4.2.3	Stopping Sweeping Rollers Operation .....	11
4.2.4	Operating the Side Brushes .....	11
4.2.5	Stopping Side Brush Operating.....	11
4.2.6	Operating the ventilation flap.....	11
4.2.7	Operating the filter-cleaning device.....	12
4.3	Parking the sweeper .....	12
4.4	Emptying the dustbin .....	13
4.4.1	Removing the dustbin.....	13
4.4.2	Inserting the dustbin .....	14
5.1	Safety Information.....	15
5.2	Cleaning.....	15
5.3	Replacing the filter .....	16
5.3.1	Removing the filter.....	16
5.3.2	Fitting the filter .....	17
5.4	Replacing the Side Brush .....	17
5.4.1	Dismounting the Side Brush.....	17
5.4.2	Mounting the Side Brush .....	18
5.4.3	Adjustment of the Side Brush.....	18
5.5	Sweeping Rollers Replacement.....	19
5.5.1	Dismounting the Sweeping Rollers .....	19
5.5.2	Installing the Sweeping Rollers .....	20
5.6	Setting the Sweeping Rollers.....	22
5.6.1	Sweeping Contour Adjustment.....	22
5.6.2	Establishing the Sweeping Contour: .....	22
5.6.3	AdJusting the Sweeping Contour.....	22
5.7	Drive.....	24

## Table of Contents

---

5.7.1	Adjustments .....	24
5.7.2	Inspecting the drive .....	24
5.8	Adjustment of the drive .....	26
5.9	Battery .....	28
5.9.1	Charging the Batteries .....	29
5.10	Maintenance Chart .....	30
5.10.1	Daily maintenance .....	30
5.10.2	After each 50 operating hours also .....	30
5.10.3	After each 100 operating hours also .....	30
5.10.4	After each 200 operating hours also .....	30
5.11	Malfunctions / error messages and troubleshooting .....	31
5.12	Technical Data .....	32
5.13	Product marking .....	33
5.14	Disposal .....	33
5.15	Accessories and spare parts .....	33
5.16	Service .....	33
5.17	Transport .....	33

---

# 1 Introduction

This operating manual contains instructions for using the hand-operated sweeper.

Our products are subject to continuous improvement. Therefore, design changes that were made after this manual went to print could not be incorporated. If you have any questions, please contact our Service department.

The operating manual must be read and applied by all persons who operate the sweeper.

Apart from the operating manual and the regulations for accident prevention applicable in the country of use and the location of use, the common, recognised rules for safe and technically correct working must also be followed.

## 1.1 Usage conformant with intended purpose

The appliance is intended exclusively for sweeping on solid surfaces (for example.: parking areas, walkways, shop floors). The area to be swept should not be wet.

The sweeper may only be used by reliable and instructed personnel. prevent children, juveniles and other unauthorised persons from using the machine (e.g. by pulling out the key after use).

Any other use, or any use over and above that, will be considered to be non-conformant with intended purpose. The manufacturer rejects any and all liability for damage resulting from such use. The risk is that of the user alone.

Usage conformant with intended purpose also includes compliance with the operating manual and the inspection and maintenance specifications. Drive the sweeper only along expressly marked routes and spaces.

---

## 2 Safety information

---

1. The machine should only be used in a flawless state, as well as in keeping with its intended purpose, in a safety-conscious and risk-conscious manner and in compliance with these operating instructions.
2. In addition to the operating manual, please heed general legal and other binding regulations for accident prevention and environmental protection.
3. Sweeping and picking up of flammable, toxic or explosive substances, along with flammable gases or diluted acids and solvents, burning or smouldering objects is prohibited!
4. The appliance is not suitable for picking up fluids, cables, cords, wires or the like.
5. The machine should only be used with the dust box fitted to prevent injuries caused by parts being slung out.
6. Transporting loads with the sweeper is not allowed.
7. Faults should be eliminated immediately, particularly those that could impair safety.
8. Do not make any changes, modifications or additions to the sweeper without the approval of the manufacturer.
9. Replacement parts must meet manufacturer specifications. This is always ensured by using original replacement parts.
10. Ensure that operating media, auxiliary media and replacement parts are disposed of in a safe and environmentally-friendly manner, particularly batteries!
11. Suitable non-slip footwear should be worn to avoid accidents.
12. If you have any questions, please contact our Service department.
13. Persons (including children) who are not able to use this machine safely due to their physical, sensory or mental capabilities or their inexperience or lack of knowledge may not use this machine without the supervision or instruction by a responsible person! Children should be supervised to ensure that they do not play with the appliance.
14. Caution: loose clothing can be caught and drawn in on rotating parts.
15. The operating instructions provided by the battery manufacturer relating to his product and legal specifications for the handling of accumulator batteries should be heeded!

- 
16. Charge flat batteries directly after use and only in well-ventilated rooms.
  17. Keep naked flames and electrical sparks away from the charging area, since a highly-explosive electrolytic gas mixture is generated when batteries are being charged.
  18. Note that the accumulator batteries are filled with battery acid.
  19. Batteries should always be kept clean and dry to avoid leakage currents! Never short-circuit battery poles!
  20. Smoking, eating and drinking should be avoided in the vicinity of the battery charging station to avoid risks to health.
  21. Batteries should only be charged with the hood opened and secured with the holder.

### 3 Device Description

An electric motor drives the suction sweeper which includes forward and reverse movement. The sweeping mechanism ST1000E<sub>with</sub>TRS features two lateral brushes which carry the refuse to two sweeping rollers mounted parallel to the direction of motion.

These project the sweepings overhead into the dustcontainer positioned behind it. If necessary, the dust stirred up by the sweeping rollers is caught by the dust suction unit in a lamellar filter inside the machine.

The lamellar filter can be cleaned through a mechanically- operated filter cleaning device. If necessary the dust extraction can be closed off with a diaphragm to protect the filter from humidity.

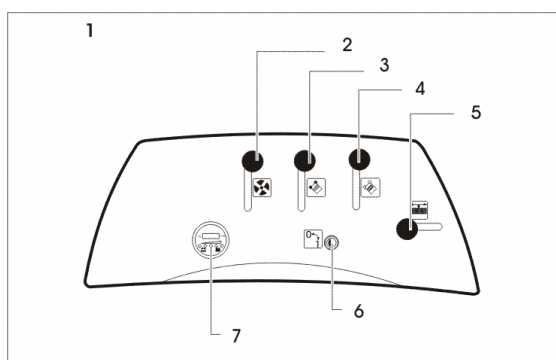

- |                             |                               |
|-----------------------------|-------------------------------|
| 1 Control panel             | 2 Lever for ventilation flap  |
| 3 switch for side brushes   | 4 switch for sweeping rollers |
| 5 Lever for filter cleaning |                               |

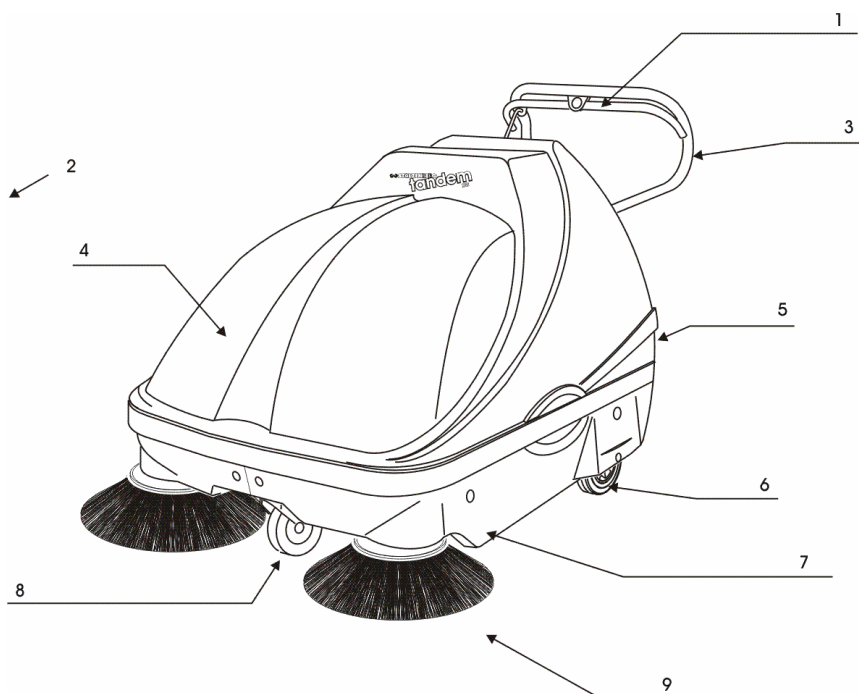

- |                         |
|-------------------------|
| 1 Driving lever         |
| Forward drive           |
| Moving backwards        |
| 2 forward drive         |
| 3 Driving hoop          |
| 4 main trim panel       |
| 5 dust container        |
| 6 driving wheel         |
| 7 left side trim panel  |
| 8 Steerable front wheel |
| with parking brake      |
| 9 side brushes          |

---

## 3.1 Initial Startup

### 3.1.1 Unpacking and mounting

CAUTION!



- Open the packaging and carefully lift the machine off the pallet.

---

**Make sure you do not damage the side and rear rubber flaps!**

---

- Lift the main panelling at the rear, and take the pins of the hood out of their nests.
- Remove the entire main panelling.
- Unscrew the four star handles and remove the outer plastic washers.
- To define the height adjustment of the driving hoop, you will have to remove the frontal carriage bolts and set it to one of the three height-levels.

In doing so observe the following:

- Upper most position: driving hoop low.
- Lowest position: driving hoop high (tall operators).
- Push the driving hoop and the driving linkage through the opening of the control panel.

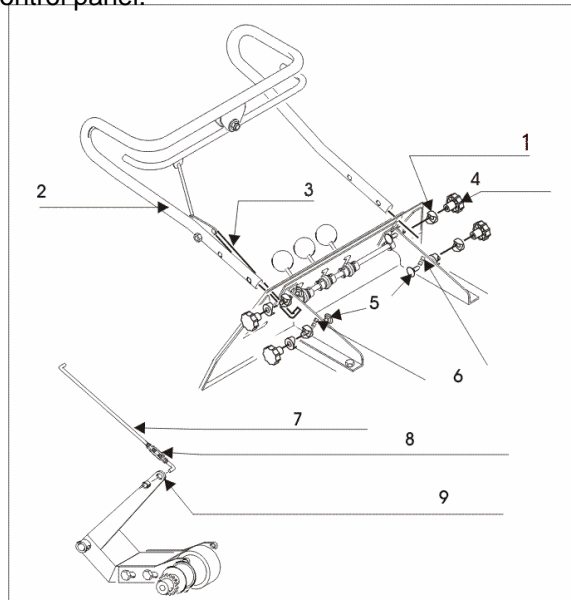

- |   |                                      |   |                                       |
|---|--------------------------------------|---|---------------------------------------|
| 1 | Driving hoop                         | 2 | Driving linkage                       |
| 3 | Outer plastic washer                 | 4 | star handle                           |
| 5 | Front carriage bolt                  | 6 | Height-adjustment of the driving hoop |
| 7 | Driving linkage                      | 8 | Turnbuckle of the driving linkage     |
| 9 | Borehole of the frontal swivel lever |   |                                       |



---

**CAUTION!**



---

**Make sure that the driving linkage is guided through the corresponding opening of the control panel.**

**If the driving linkage is not properly installed, the suction sweeper will not operate.**

**Do not change the screw connection of the driving linkage. This screw connection is preset to the highest driving hoop adjustment, meaning the lowest position of the frontal carriage bolts.**

**If you change the screw connection, the drive of the machine will be effected!**

- 
- Push the four carriage bolts through the boreholes of the driving hoop.
  - Push the four outer plastic washers on the ends of the carriage bolts.
  - Re-fasten the star handles to the carriage bolts.
  - Place the driving linkage in the borehole of the frontal swivel lever.
  - Secure this linkage with the set collar.

**WARNUNG**



---

**By all means, make sure that the suction sweeper is turned off before you connect the battery poles. Key of the key-operated switch to 0. Remove key!**

- 
- Connect the poles of the battery.
  - To mount the lateral brushes, push the lateral brushes on the lateral brush axle.
  - Fasten the lateral brushes by sliding the spring plug through the boreholes of the lateral brushes and the lateral brush axle.

**WARNUNG**



---

**By all means, make sure that the brushes of the lateral brushes are approximately 5-10 mm from the ground with the lateral brush lever in raised position!!!**

---

Should you neglect to adhere to this distance, it will result in poor sweeping or increased wear and tear of the brushes.

- Re-attach the main panelling.
- Close the main panelling.

The suction sweeper is ready for operation.

---

## 4 Operation

### 4.1.1 Driving

Starting the Sweeping & Suction Machine

**WARNUNG**



**Make sure the suction sweeper is on level ground when you loosen the parking brake, or secure the suction sweeper to prevent accidental rolling.**

- Loosen the parking brake of the front wheel.
- To do this use the upper unlocking lever.

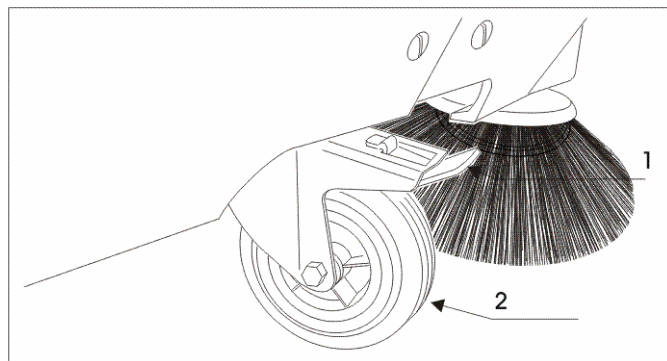

1 Parking brake

6 Front wheel

- Insert the key into the key-operated switch.
- Turn the key clockwise.

The machine starts.

- Release the key.

Moving forward:

- Pull the right-hand part of the driving lever upwards.

The suction sweeper moves forward.

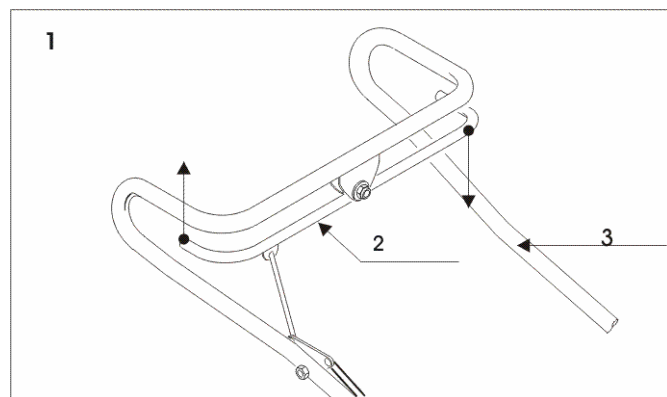

1 Moving forward

6 Driving lever

2 Driving hoop

---

Moving backwards:

- Pull the left-hand part of the driving lever upwards.

The suction sweeper moves backwards.

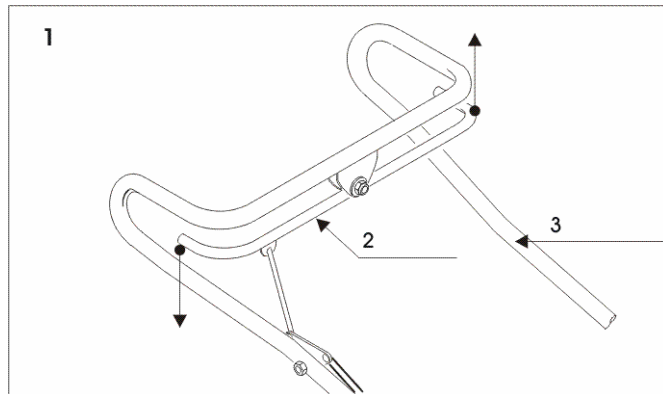

- 1 Moving backwards  
2 Driving hoop  
6 Driving lever

## 4.2 Sweeping operation

### 4.2.1 Safety Information

Do not switch on suction when sweepings are wet. This will cause damage to the suction device and the filter. Provide good aeration when using the machine in closed rooms or buildings. Do not sweep up materials that may cause health impairment.

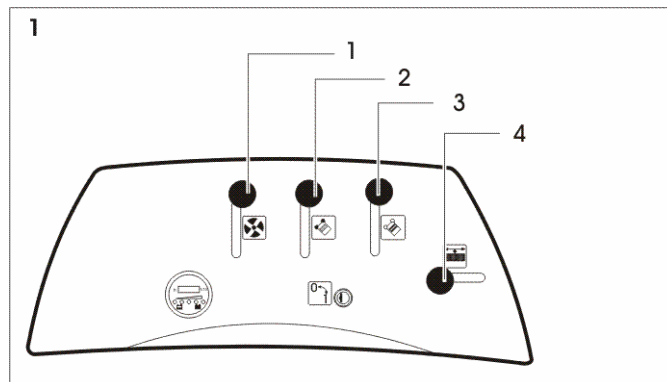

- 1 Control panel  
2 switch for side brushes  
3 lever for filter cleaning  
6 lever for ventilation flap  
7 switch for sweeping rollers

---

#### **4.2.2 Operating the Sweeping Rollers**

- Lever down = working position
- Lever up = sweeping rollers will not operate
- Start the Sweeping & Suction Machine
- Unlatch the lowering lever of the sweeping roller.
- Push down the lowering lever.

#### **4.2.3 Stopping Sweeping Rollers Operation**

- Lift the sweeping rollers and arrest the lowering lever of the sweeping rollers
- Let the lever snap in arresting position.

#### **4.2.4 Operating the Side Brushes**

- Lever down = working position
- Lever up = lateral brushes will not operate
- Start the Sweeping & Suction Machine.
- Unlatch the lowering lever of the side brushes.
- Push the lever down.

#### **4.2.5 Stopping Side Brush Operating.**

- Pull up the lowering lever for the side brushes.
- Let the lever snap in arresting position.

#### **4.2.6 Operating the ventilation flap**

- Lever down = ventilation on
- Lever up = ventilation off

The purpose of the ventilation flap is to protect the machine when sweeping moist surfaces.

If the ventilation is on, the dust extraction will be turned off.

- To turn on the ventilation, pull the lever of the ventilation flap upwards.
- If you want to sweep on a dry surface again, you will have to push down the lever down.

If you are sweeping a dry surface and the sweeping performance is poor or a lot of dust swirls up, you will have to check the position of the lever for the ventilation flap.

---

### 4.2.7 Operating the filter-cleaning device

The filter cleaning device prevents the lamellar filter from being blocked by debris.

- Close the ventilation flap.
- Make sure the dust collector has been installed
- Move the lever of the filter vibrating device continuously, about ten times back and forth.
- Afterwards open the ventilation flap.

### 4.3 Parking the sweeper

Turning Off the Sweeping & Suction Machine

CAUTION



---

**Make sure the suction sweeper is on level ground when you loosen the parking brake, or secure the suction sweeper to prevent accidental rolling!**

---

- Release the driving lever.
- Lift the lateral brushes and arrest the lowering lever of the lateral brushes.
- Lift the sweeping rollers and arrest the lowering lever of the sweeping rollers.
- Turn the key counter clockwise and take it out off the key operated switch.
- Pull the machine towards in yourself, to ensure that the front wheel is straight.
- Secure the machine from rolling by kicking down the brake lever of the front wheel.
- If the brake is relieved afterwards, the brake lever has to remain depressed position.

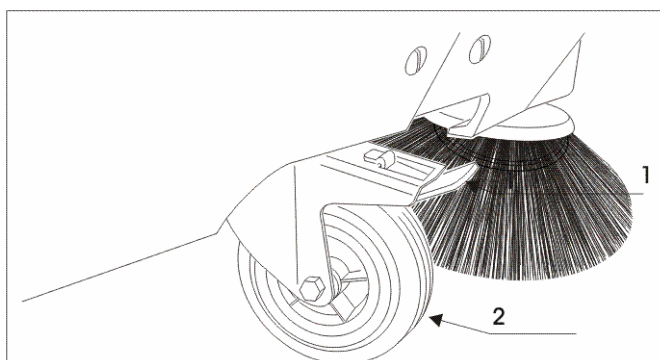

1 Parking brake

6 Front wheel

**DANGER!**



**Incorrect handling of the Sweeping & Suction Machine may lead to severe harm to persons or objects!**

## 4.4 Emptying the dustbin

Refuse is collected in the dustbin. This is located at the rear of the suction sweeper.



The dustbin must be emptied regularly, and at least each time the sweeper is used.

### 4.4.1 Removing the dustbin

- Pull the attachment lugs off the holding knobs on both sides
- Pull the dustbin out of the suction sweeper by the handle until the front dustbin guides are free.

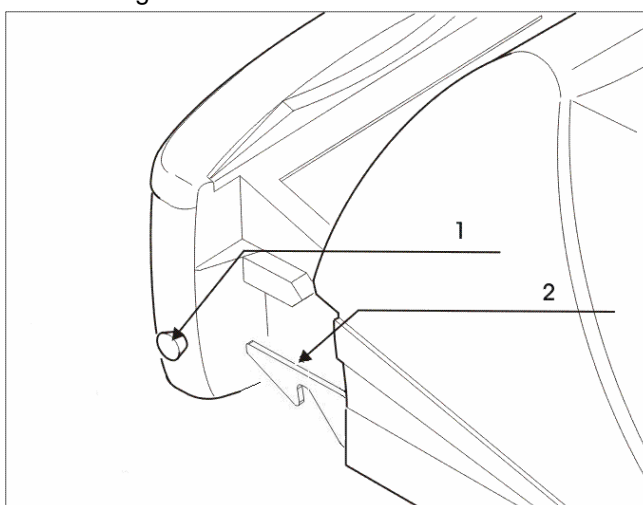

1 Dustbin fixing knob

6 Dustbin arrest



---

There are two guide rollers at the rear end of the dustbin to facilitate its removal. Underneath the dustbin are guide rollers and a recessed grip.

---

- Lower the dustbin to the ground.
- Pull the dustbin fully out of the suction sweeper.
- To empty the dustbin, insert your other hand into the recessed grip.
- Refuse is emptied out via the lower edge of the dustbin dirt collector.
- Empty the refuse into an appropriate container only.



#### 4.4.2 Inserting the dustbin

- Place the dustbin in front of the dustbin mount.
- Raise the front dustbin guides to the height of the guide rails.
- Push the arrests to the side
- Push the dustbin into the suction sweeper.
- Push the arrests onto the fixing knobs of the dustbin.

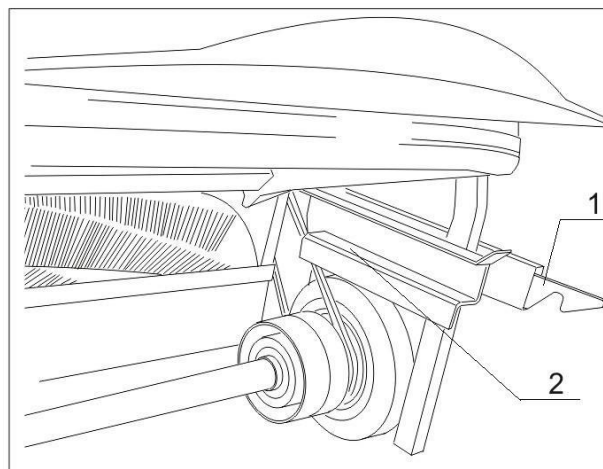

1 Dustbin arrest

6 Dustbin guide rail

---

## 5 Maintenance

### 5.1 Safety Information

Only complete the type of maintenance work described in the following chapter. All other maintenance and upkeep work may only be carried out by the manufacturer or by companies and persons authorised by the manufacturer, who are familiar with the relevant safety specifications, because portable devices in industrial use are subject to the safety test according to VDE 0701.

Closely follow the steps listed in the maintenance instructions. The improper completion of maintenance tasks may result in malfunctions when using the sweeper and may possibly render the warranty granted null and void.

When working on the electrical system, the battery should be disconnected.

Maintenance work/ troubleshooting at the electric motor must not be done while the electric motor is running.

Use only flawless and appropriate tools to complete maintenance work.

Note the requirements for spare parts.

If covers and/or safety devices were removed during maintenance work/repairs, they will have to be reattached prior to starting the sweeper.

For carrying out any work on the sweeper, it must be switched off and secured from rolling away by accident.

### 5.2 Cleaning

The suction sweeper may only be cleaned in the off state, when it is dry.

The suction sweeper is a machine with electrical components.

**WARNING**



---

**Moisture damages the electronics of the device. Moisture can result in leakage currents and short-circuits.!**

---

**Do not use any high-pressure cleaners**



---

## 5.3 Replacing the filter

The filter serves to separate off fine dust. The filter is cleaned mechanically by the filter vibrator.

### 5.3.1 Removing the filter

- Shut down the suction sweeper, as described.
- Remove the dustbin from the machine
- Remove the hood.

The filter is positioned on a frame.

- Hold the filter frame in position with one hand.
- Press the clips of the tension closures downwards.
- Release the threaded hooks from the filter frame arrests.
- Remove the frame with the filter in a downwards direction.
- Remove the filter from the frame.

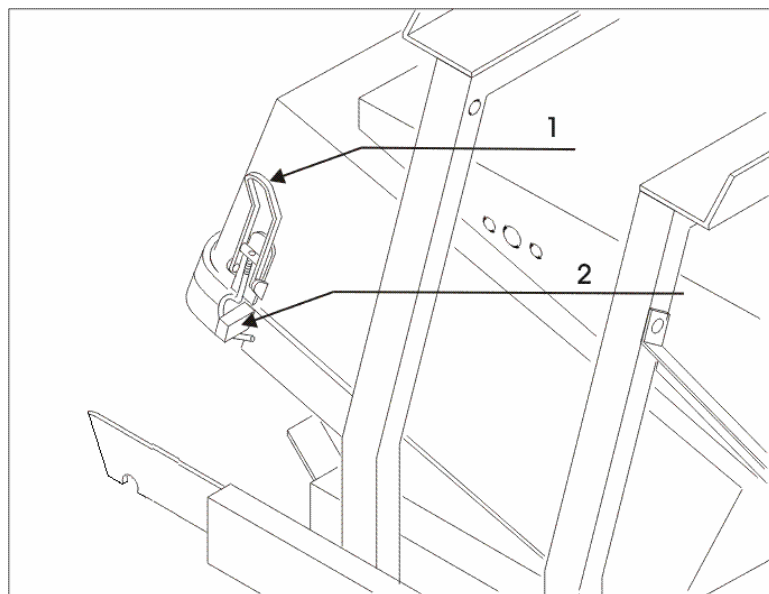

1 Tension closure

6 Filter frame arrest

---

### 5.3.2 Fitting the filter

- Place the filter on the frame.
- Fold the frame upwards.
- Push the threaded hooks over the filter frame arrests.
- Press the clips of the tension closures upwards.
- Push the dustbin back into the machine.

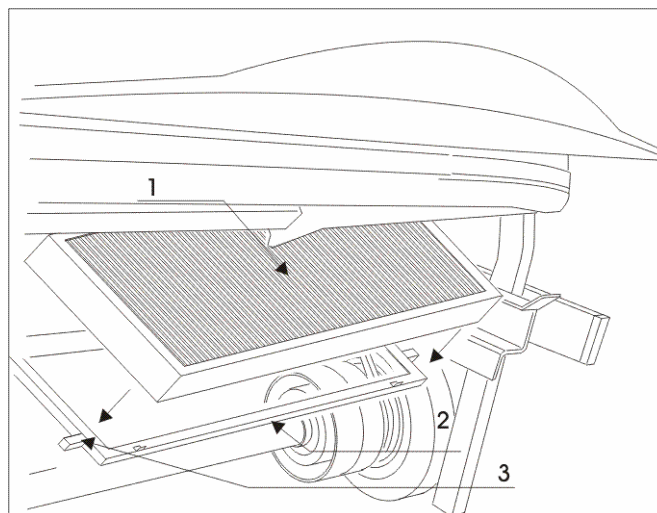

- 1 Filter
- 2 Filter frame arrest
- 6 Filter frame

## 5.4 Replacing the Side Brush

### 5.4.1 Dismounting the Side Brush

- Park the suction sweeper as described.
- Take the key out of the key-operated switch.
- Pull up the lowering lever for the side brushes.
- Arrest the lowering lever.
- Pull off the spring plug from the axle of the lateral brushes.

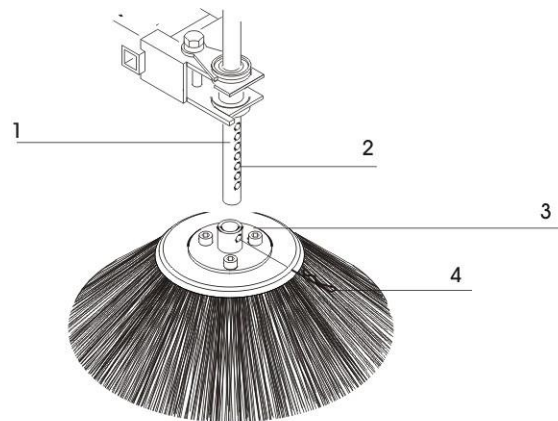

- |                                 |               |
|---------------------------------|---------------|
| 1 Borehole                      | 2 Borehole    |
| 3 Flange of the lateral brushes | 4 Spring plug |

- Pull the side brush down and off.
- Replace the side brush.

#### 5.4.2 Mounting the Side Brush

- Fasten the flange plate to the side brush.
- Push the lateral brush on the axle of the lateral brushes.
- Push the spring plug through the borholes of the lateral brush flange plate and through the borehole of the axle of the lateral brushes (until ground contact).

#### 5.4.3 Adjustment of the Side Brush

Operational wear necessitates additional adjustment of the side brushes.

- Park the suction sweeper as described.
- Take the key out of the key-operated switch.
- Unlatch the lowering lever of the side brushes.
- Push down the lowering lever.
- Remove the entire main panelling.

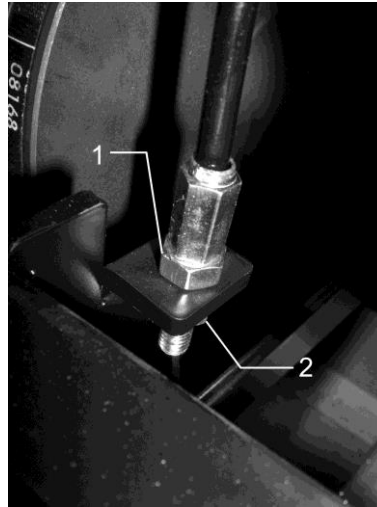

1 Screw of the height-adjustment of the lateral brushes

2 Back nut

- Loosen the back nut.
- To lower the lateral brush, you will have to turn the screw of the height-adjustment of the lateral brushes clockwise.
- To raise the lateral brushes, you will have to turn the screw of the height-adjustment of the lateral brushes counterclockwise.
- Set the lateral brushes to their desired position.
- Tighten the back nuts. Put on the main panelling.

## 5.5 Sweeping Rollers Replacement

### 5.5.1 Dismounting the Sweeping Rollers

- Park the suction sweeper as described on page 10.
- Take the key out of the key-operated switch.
- Pull lowering lever of the sweeping rollers.
- Arrest the lowering lever.
- Loosen the bolts of the left side trim panel facing in driving direction.
- Remove the side panel.

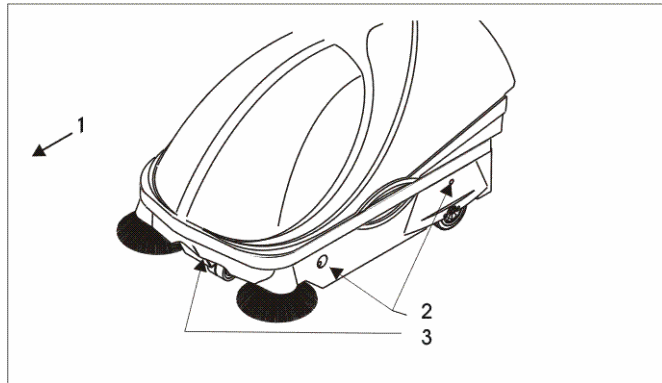

1 forward drive

6 fastening bolts of side trim panel

- The roller swing is held in place by three star handles.
- Loosen the star handles.
- Remove the roller swing.

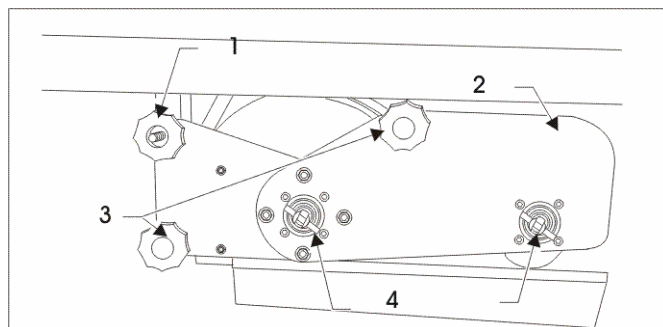

1 open star handle

6 roller swing

2 star handle

7 turning lever

- Pull the sweeping rollers out of the machine and remove any debris, cords, etc., from the roller tunnel and from the pick-up pins.

### 5.5.2 Installing the Sweeping Rollers

- Push the sweeping rollers under the machine.
- Observe the sweeping rollers' sense of rotation while sliding them in.

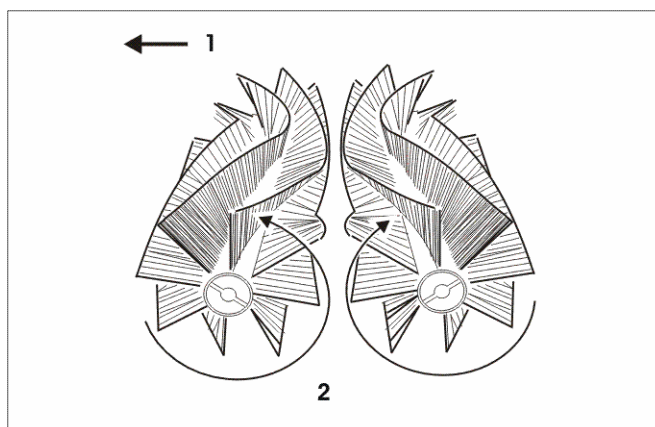

1 forward drive

6 direction of motion of the sweeping rollers

Each roller end is equipped with a keyway. Turn the sweeping roller until the pick-up pin of the rear roller swing fits into the keyway of the sweeping roller. Slide the sweeping rollers in as far as possible.

Set the front roller swing onto the free sweeping roller ends.

The roller swing is equipped with two turning levers.

Each turning lever end is equipped with one pick-up pin.

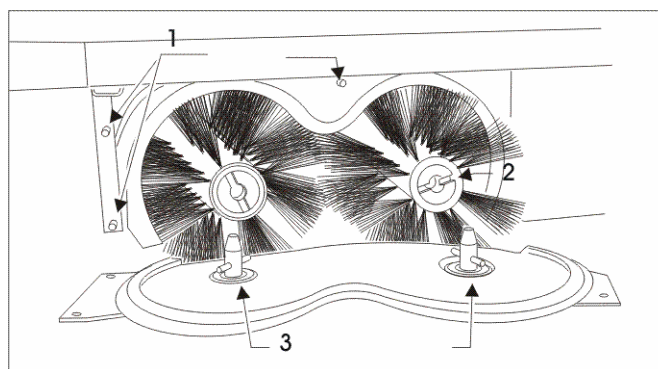

1 threaded rods

6 sweeping roller keyway

2 pick-up pin

- Turn the turning lever until the pick-up pin fits into the keyway of the sweeping rollers.
- Push the roller swing over the threaded rods.
- Make sure the sweeping rollers are fitted on both sides by the keyway into the pick-up pins and that all star handles are firmly tightened.
- Fasten the side trim panel.

---

## 5.6 Setting the Sweeping Rollers

### 5.6.1 Sweeping Contour Adjustment

For best cleaning results and to ensure the highest possible device efficiency, the sweeping rollers are equipped with a sweeping contour. The sweeping contour should be set to approx. 30-40 mm at the rear roller.

### 5.6.2 Establishing the Sweeping Contour:

Drive the Sweeping & Suction Machine to an area to be cleaned. Switch on the sweeping rollers without moving the sweeping machine. Allow the sweeping rollers to run for about one or two minutes without moving. Lift the sweeping rollers. Stop sweeping rollers operation and drive forward a few meters. The sweeping track visible on the ground is the sweeping contour.

### 5.6.3 AdJusting the Sweeping Contour

- Park the suction sweeper as described.
- Take the key out of the key-operated switch.
- Lift the sweeping rollers and arrest the lowering lever of the sweeping rollers.
- Let the lever snap in arresting position.
- Open the hood.
- Secure the hood position by the hood arresting device.
- Remove the right side trim panel facing in the direction of motion.

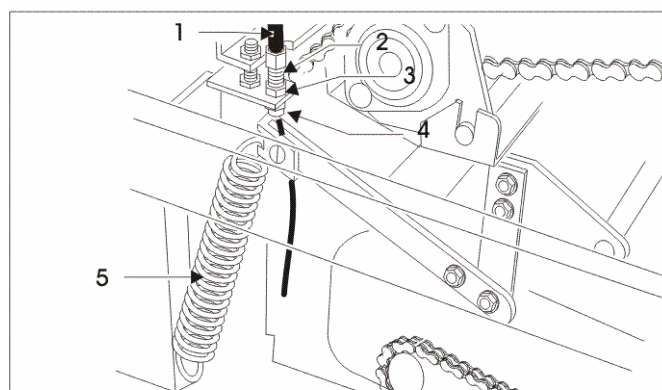

- 1 Bowden pull wire
- 2 counternut A
- 3 spring

- 6 threading rod
- 7 counternut B

---

#### Increasing the Sweeping Contour by Lowering Sweeping Rollers

- Loosen counter nut A on the threading rod of the Bowden pull wire.
- Turn counternut A counterclockwise.
- Now lock counternut A in place by counternut B.

#### Decreasing Sweeping Contour by Lifting Sweeping Rollers

- Loosen counternut B
- Turn counternut B clockwise by a few more threads.
- Lock counternut B in position by counternut A.

---

#### WARNUNG



#### Attention!

**The sweeping rollers are pendulous and adapt to uneven surfaces up to a certain degree. They are put into operating position by means of the rotation only. Only the tips of the brushes will touch the ground when lowering the device during standstill. That is why force on the sweeping roller lever will only be exerted when the brushes are rotating!**

---

#### Further Possible Adjustment:

- Park the suction sweeper as described on page 10.
- Take the key out of the key-operated switch.
- Lift the sweeping rollers and arrest the lowering lever of the sweeping rollers
- Let the lever snap in arresting position.
- Open the hood.
- Secure the hood position by the hood arresting device.
- Remove the right side trim panel facing in the direction of motion.
- Loosen the holding screw.
- Move sweeping roller retaining to desired position.
- Tighten up the holding screw again and mount the side trim panel.



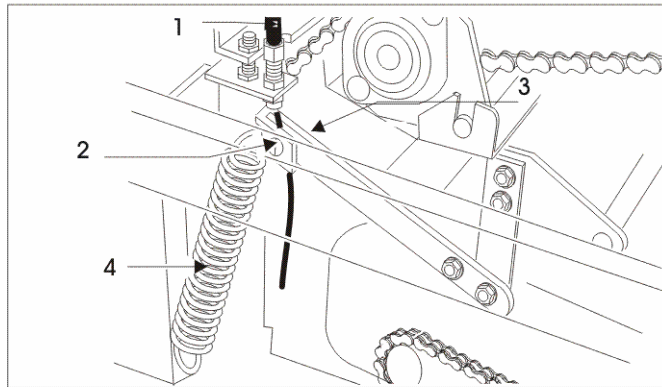

- |   |                  |   |                           |
|---|------------------|---|---------------------------|
| 1 | Bowden pull wire | 6 | sweeping roller retaining |
| 2 | holding screw    | 7 | spring                    |

For your Information:

Original roller diameter: 230 mm. When diameter has decreased to 200 mm, the roller needs to be replaced.

## 5.7 Drive

### 5.7.1 Adjustments

Adjustment of the frictional wheel will be necessary, if the forward driving performance is unsatisfactory despite high motor speed, due to damage of the frictional wheel, or it is not adequately pushed against the roller of the frictional wheel.

If the driving performance is not satisfactory in reverse, check the driving belt for dirt or damage.

### 5.7.2 Inspecting the drive

- Park the suction sweeper as described.
- Take the key out of the key-operated switch.
- Remove the main panelling.
- Check the frictional wheel and the driving belt for damages and dirt.
- If the frictional wheel and/or the driving belt are damaged or unfir for use, please inform customer service.
- Clean the frictional wheel if it is dirty.

Inspecting the drive of the frictional wheel If the frictional wheel is not damaged:

- Release the parking brake.

- Insert the key into the key-operated switch.
- Start up the suction sweeper.

**DANGER**



**Danger of injury due to moving parts!**

**When starting up the suction sweeper make absolutely sure that no one is present in the immediate vicinity of the opened suction sweeper. Make sure that the suction sweeper is secured to prevent accidental rolling.!**

- Carefully actuate the driving lever to move forward.

The swivel lever pushes the frictional wheel in the direction of the frictional roller. The suction sweeper has to move forward.

If there is no forward motion, if the frictional wheel does not push against the frictional roller:

- Park the suction sweeper as described.
- Adjust the frictional roller as described below.

**DANGER**



**If the frictional wheel pushes against the frictional wheel roller, the driving belt has to be freely movable to drive in reverse!**

Inspecting idling of the drive:

Inspection is necessary to prevent the suction sweeper from moving forward or backward, if the driving lever is in neutral position (horizontal position) when the engine is running.

- Park the suction sweeper as described.
- Take the key out of the key-operated switch.
- Remove the main panelling.

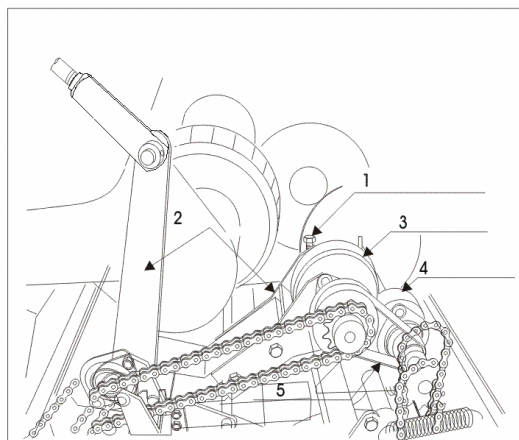

- |                    |                           |
|--------------------|---------------------------|
| 1 Adjustment screw | 2 Swivel lever            |
| 3 Frictional wheel | 4 Frictional wheel roller |
| 5 Driving belt     |                           |

---

The adjustment screw of the frictional wheel and the driving belt is located on the swivel lever. Check the position of the swivel lever:

- Insert the key into the key-operated switch.
- Start up the suction sweeper.
- Put the driving lever in neutral position (horizontal position).
- The swivel lever cannot push the frictional wheel against the frictional roller.
- The driving belt has to be freely movable.

Should this not be the case, continue as described in adjustments.

If the swivel lever is positioned correctly:

- park the suction sweeper.
- Re-attach the main panelling.

## 5.8 Adjustment of the drive

Re-adjustment is necessary due to wearing of the frictional wheel depending on use.

- Park the suction sweeper as described.
- Take the key out of the key-operated switch.
- Remove the main panelling.

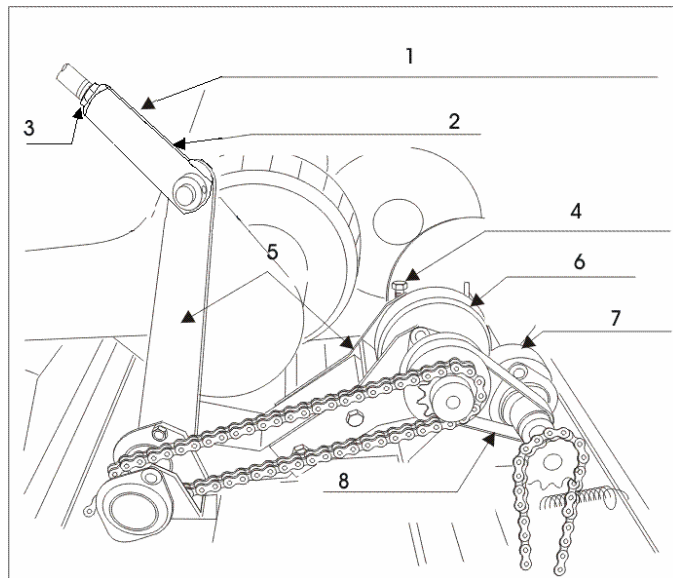

- |   |                                   |   |                              |
|---|-----------------------------------|---|------------------------------|
| 1 | Frok crown of the driving linkage | 6 | Driving linkage              |
| 2 | Back nut                          | 7 | Adjustment of the free wheel |
| 3 | Swivel lever                      | 8 | Frictional wheel             |
| 4 | Frictional wheel roller           | 9 | Driving belt                 |

- 
- Loosen the back nuts of the turnbuckle of the driving linkage.
  - To reduce the distance between the frictional roller and the frictional wheel, you will have to turn the turnbuckle counter clockwise.

**WARNUNG**



---

**Make sure you only only turn the turnbuckle one or two threads.**

**Turning the the turnbuckle too far, could result in the dangerous possibility that both rods of the driving linkage might not find sufficient support and fall apart during operation!**

---

Check the position of the swivel lever:

- Insert the key into the key-operated switch.
  - Start up the suction sweeper.
  - Carefully actuate the driving lever to move forward.
  - The swivel lever has to push the frictional wheel against the frictional roller.
  - The driving belt has to be freely movable.
  - The suction sweeper has to move forward.
  - Carefully actuate the driving lever to move backwards.
  - The swivel lever has to separate the frictional wheel from the frictional roller.
  - The driving belt has to be tight.
  - The suction sweeper has to move backwards.
- 

**WARNUNG**



---

**If the frictional wheel pushes against the frictional roller, the driving belt has to be freely movable to drive in reverse!**

**When actuating the driving lever to move backwards the driving belt has to be tight and the frictional wheel has to be separated from the frictional roller!**

---

Should these conditions be evident:

- re-tighten the back nuts.
- re-attach the main panelling.

Should the suction sweeper not move forward and/or backwards: repeat these adjustments

---



When making adjustments should the condition arise that while the driving lever is in no-load condition, the machine, with the engine running, should "creep" forward or backwards, then the neutral position of the free wheel has to be adjusted.

---

To do this, loosen the back nut of the free wheel adjustment.

---

---

If the machine "creeps" backwards:

- turn the screw of the free wheel adjustment counter clockwise, until you can move the driving belt freely.

If the machine "creeps" forward:

- turn the screw of the free wheel adjustment clockwise to tighten the pull-back spring.

If the free wheel works properly again:

- tighten the back nuts.

## 5.9 Battery

Two batteries supply the suction sweeper with electricity. The charging condition of the batteries is indicated by the battery condition display on the control panel.

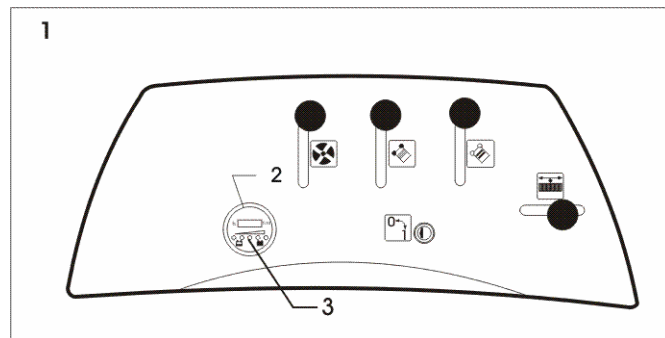

1 Control panel

2 LED`s

6 battery condition display

When the Sweeping & Suction Machine is switched on the red LED flashes five times. Subsequently the electronic system of the Sweeping & Suction Machine carries out a self-testing operation of the battery charging state.

The result of this self-testing is displayed by the 5 LED`s.

Information provided by LED indicators on the battery condition display:

lit LED	Charging condition of battery
Red Yellow Green Green Green	
☀ ☀ ☀ ☀ ☀	condition fully charged
☀ ☀ ☀ ☀ ○	operating/charging condition uncritical
☀ ☀ ☀ ○ ○	operating/only for a short time longer
☀ ☀ ○ ○ ○	operating/soon critical
☀ ○ ○ ○ ○	operating/critical

### 5.9.1 Charging the Batteries

- Turn off the Sweeping & Suction Machine.
- Open the hood.
- Secure the hood position by the hood arresting device.
- Pull apart the red main battery connector.
- Connect the loading device to the loose loading plug of the suction sweeper.
- Connect the mains plug of the charging device to a power supply socket.

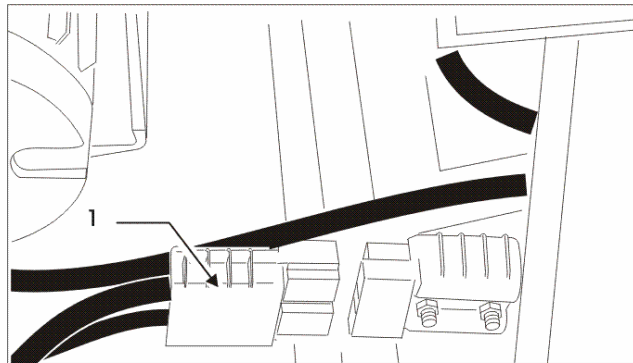

1 loose loading plug

6

When the charger supplied is used, a green control lamp serves to indicate that charging is complete.

The machine takes approx. 10 hours to charge fully (with the manufacturer's original accessories charger).

The manufacturer's original charger can/should remain connected after charging, as it has a trickle charge function, and thus ensures maximum battery capacity even after long standing times.

Ensure that the suction sweeper is only started up if there is sufficient charge left in the batteries.

The machine automatically switches off if the batteries are discharged to such an extent that damage could occur (discharge protection).

---

## **5.10 Maintenance Chart**

### **5.10.1 Daily maintenance**

- Check battery acid level, if required replenish distilled water.
- Charge battery.
- Check if machine is damaged or impaired in any way.
- Check condition of dust filter and clean if necessary.
- Empty dust container.
- Search brush - roller tunnel for jammed particles and seized up dirt that may narrow the brush tunnel and obstruct free roller brush movement.

### **5.10.2 After each 50 operating hours also**

- Check if battery leaks acid.
- Clean and grease battery poles.
- Check if sweeping rollers are worn or cluttered. Replace if required.
- Check sweeping contour, readjust if required.
- Check if side brush adjustment is worn, if required readjust or replace.
- Cleaning the frictional wheel and the driving belt (with nitro-thinner, benzene or brake cleaner)

### **5.10.3 After each 100 operating hours also**

- Check cable isolation, replace cables if required.
- Check if cable connections are tight.
- Clean dust filter, replace if necessary.
- Search suction for obstacles, clean.
- Conduct trial run to check all operating elements.
- Check if roller drive chain is elongated or loosened.
- Check all bearings for wear.
- Check if seals are damaged or dislocated.

### **5.10.4 After each 200 operating hours also**

- Check operation of electric motor.
- Check if carbon brushes are worn, replace if required.

## 5.11 Malfunctions / error messages and troubleshooting

Disturbance	Possible Cause	Remedy
No operating display at control panel:	Key switch not switched on	Turn key switch and check correct load
	Key switch not switched on	Check the fit of the main paneling.
	Fault in electrical wiring	Check plug connections
	Battery empty	Charge battery
Sweeping result unsatisfactory:	Side brush(es) or main sweeping rollers not lowered	Lower
	Side brush(es) or main sweeping rollers worn	Adjust
	Filter heavily polluted	if required switch off side brushes
	Filter not correctly fitted	
	Leakage and subsequent aspiration of false air in the filter chamber	Open the ventilation flap
		Clean filter
		check for tight fit
		check if false air is sucked in
	Brush rollers are jammed by dirt, cords, strings or the like	Dismount brush rollers and clean them
	Ator does not move freely	Check side brushes and remove obstacles
Drive wheels obstructed	Check ventilator wheel and remove any obstruction	
Frictional wheel worn out	Jack up the Sweeping & Suction Machine check differential operation of wheels and free running	



## 5.12 Technical Data

Dimension and Weight	
Length:	1190 mm
Width:	790 mm
Height:	820 mm
Weight:	
without batteries	105 kg
with batteries	125 kg
Sweeping Width:	
Main sweeping roller	600 mm
with one side brush	800 mm
with two side brushes	1000 mm
Dust Container Volume	70 ltr
Climbing Capacity:	20%
Speed:	
Forward movement	0-4 km/h
Moving backwardst	0-2,5 km/h
Filter Area:	3 m <sup>2</sup>
Volume flow turbine:	600 m <sup>3</sup> . Bei 200 pa
supporting frame :	Steel construction, powder coated
Trim Panel Parts:	impact resistant plastic

Electrical Installation	
Power supply	2 x 12 V Batterie 60 - 80 Ah K5
Running time of battery version:	ca. 2,5 - 3 Std.

Maximum Airborne Sound Level dB (A):	71 dB(A)
Vibration	< 2m/s <sup>2</sup>

---

## 5.13 Product marking



## 5.14 Disposal

Dispose of faulty parts, especially electrical components, batteries and plastic parts according to the locally applicable waste disposal specifications.

Used batteries must be disposed of according to Directive 2006/66/EC.

## 5.15 Accessories and spare parts

Accessories and spare parts must conform to the requirements of the manufacturer. This is ensured by using genuine replacement parts.

## 5.16 Transport

Transport the machine only in the switched-off condition, sufficiently well fastened.

---

## 6 EC Declaration of conformity (Translation of the original version)

**according to the EC Machine Directive 2006/42/EC, Appendix II, No. 1A**

Mr. Kai Stolzenberg – Management of the Stolzenberg GmbH & Co. KG, Hamburger Straße 15-17, D-49124 Georgsmarienhütte - is authorized to arrange technical information.

**We hereby declare that the machine described below corresponds, in its conception and construction, as well as the model brought into use by us, to the basic safety and health requirements of the EC Machine Directive 2006/42/EC. In case of a change being made that has not previously been agreed with us, this declaration will lose its validity.**

**The following standards, in particular, were applied:**

EN 292  
EN 294

DIN EN 61000-6-2  
DIN EN 60335-1  
DIN EN 60335-2-69  
DIN EN 60335-2-72

Salisbury, 28.06.2010

.....  
(General Manager)