

# VACUUM LIFTER

Lift and handle slabs with ease



The VACUUM LIFTER combined with the JIB CRANE 360 gives you the perfect lifting system for all your large and small work.

This essential piece of equipment is fitted with a pneumatic tilting piston which provides complete control of vertical and horizontal positions. A continuous air supply combined with a Venturi system generates vacuum into 3 individual pads, allowing you to hold slabs up to 500kg (maximum) and is fitted with a gauge displaying the vacuum intensity.

This accessory is also equipped with a manual cleaning system, draining away accumulated water.

# VACUUM LIFTER

Lift and handle slabs with ease

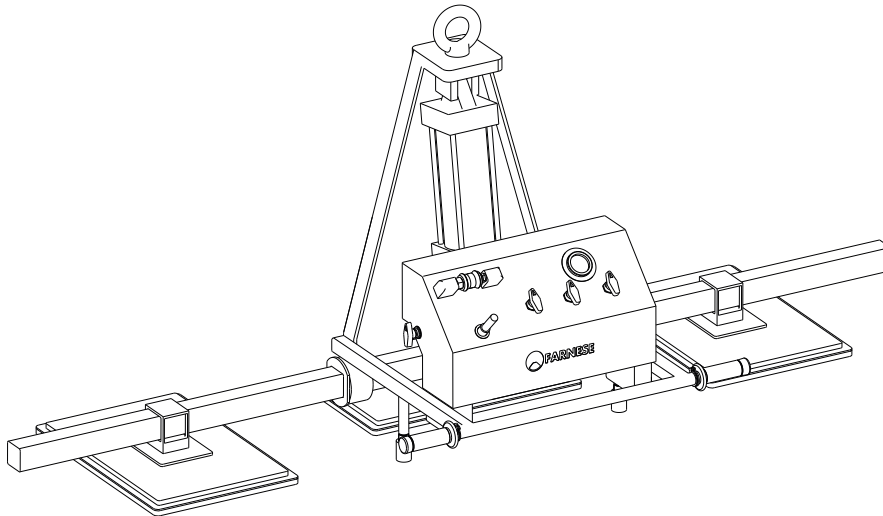
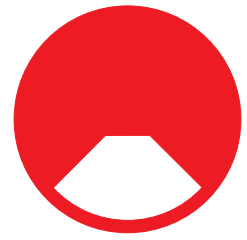

## TECHINICAL SPECIFICATIONS

DIMENSIONS OF INSTALLED EQUIPMENT	METRIC	IMPERIAL
LENGTH	2200 mm	86.6 in
WIDTH	780 mm	30.7 in
HEIGHT	850 mm	33.5 in
WEIGHT	100 kg	220.0 lb
LOAD (SAFE WORKING LIMIT)	400 kg	880.0 lb

### EQUIPMENT RANGES

AIR PRESSURE (WORKING)	7 bar	102 psi
AIR PRESSURE (CONSUMPTION)	350 l/min	92 gpm
CLEANING VALVE	YES	YES
VACUUM GAUGE	YES	YES
VACUUM GENERATOR	YES	YES
VACUUM PADS	YES   3 POS	YES   3 POS

\*CONNECTIONS REQUIRED (SUPPLIED BY CUSTOMER)

POWER, WATER, COMPRESSED AIR.