

DAS System is an auxiliary mechanism designed to facilitate locking, dismounting, and assembling the wide tires of sports cars that are difficult to disassemble. The use of this device makes the assembly and disassembly of the tire easier and more convenient. (Compatible on TC201G series)

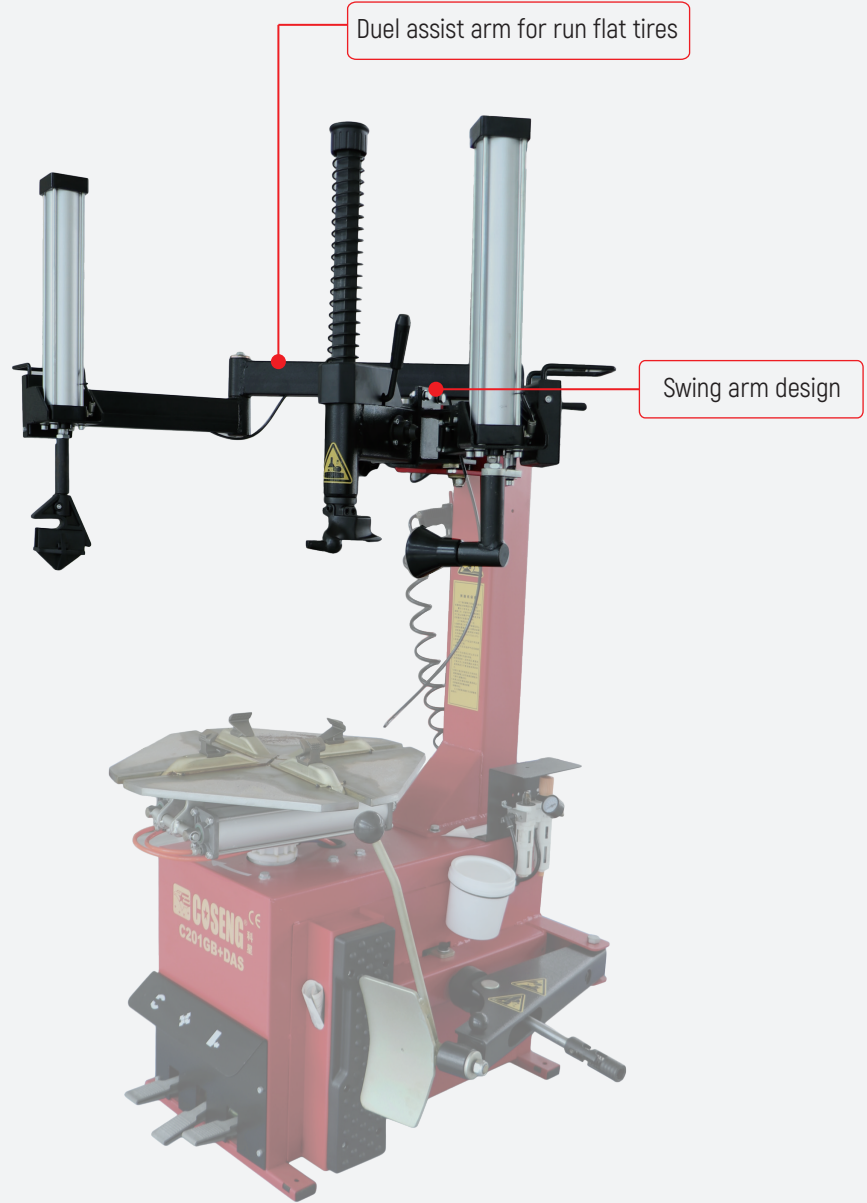
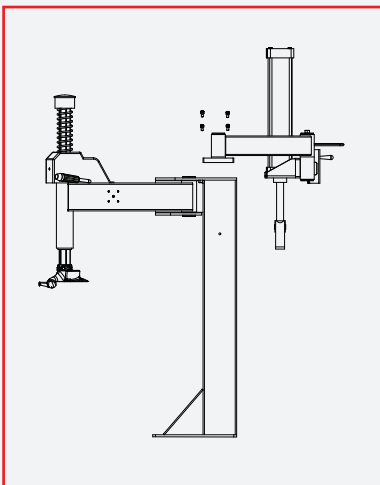
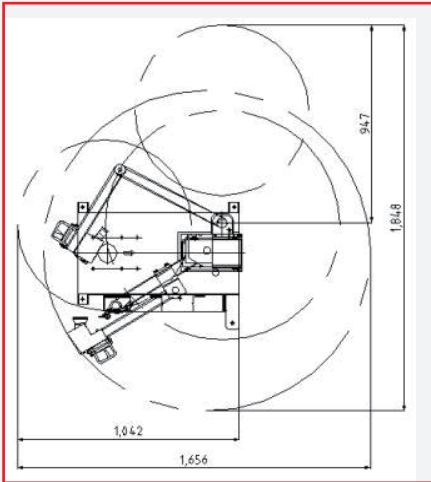

DAS Technical Params:

Working Pressure: 8-10bar

Gross Weight: 40kg

Noise during work: 70dB

Scan the code to watch the operation video



NAAR is an auxiliary mechanism designed to facilitate locking, dismounting, and assembling the wide tires of sports cars, run flat tire and PAX tires that are difficult to disassemble. The use of this device makes the assembly and disassembly of the tire easier and more convenient. (Compatible on C233G series)

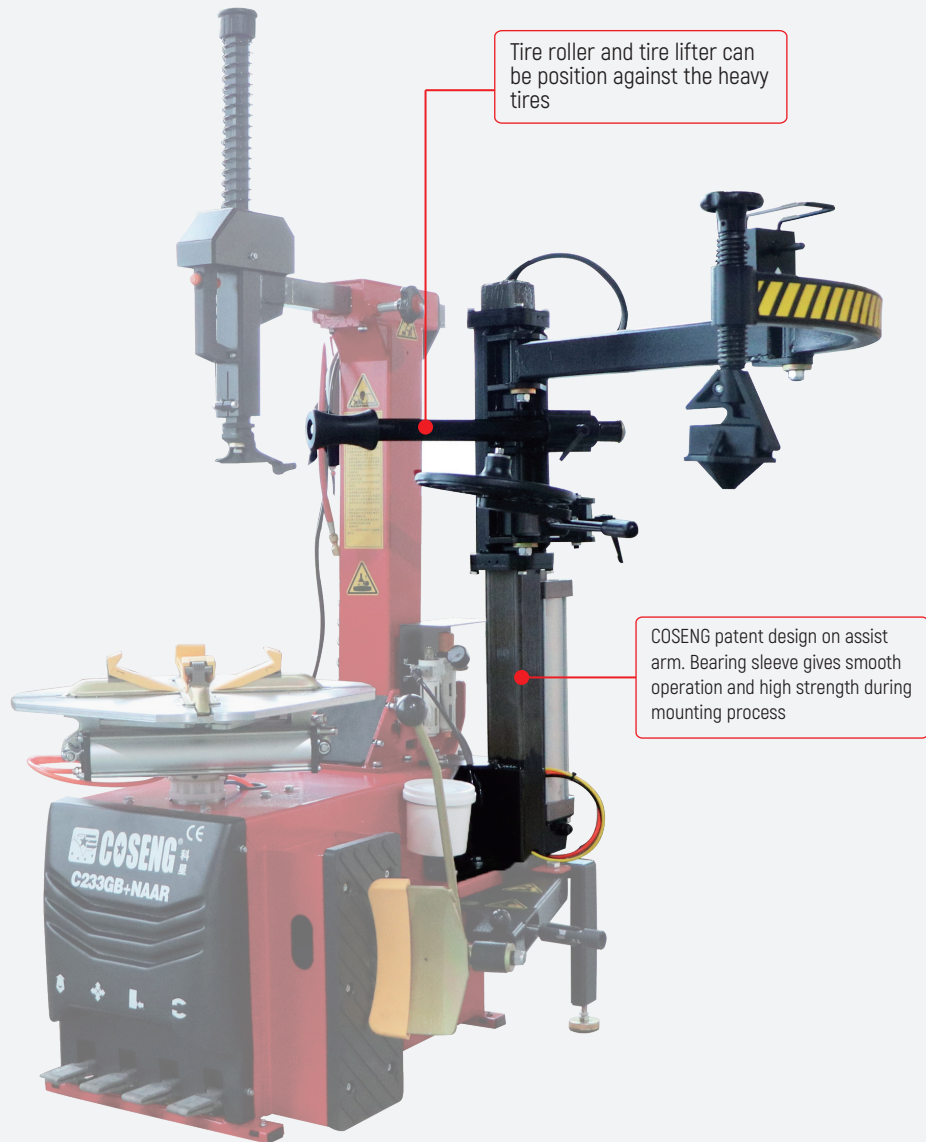
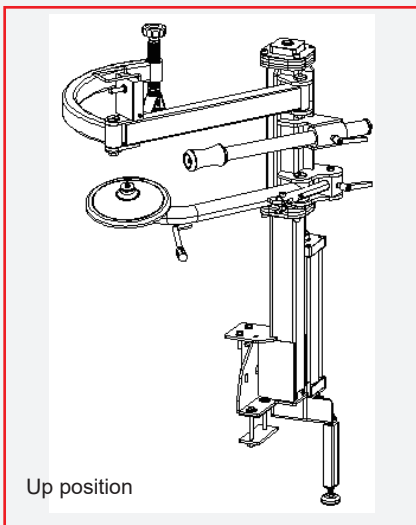
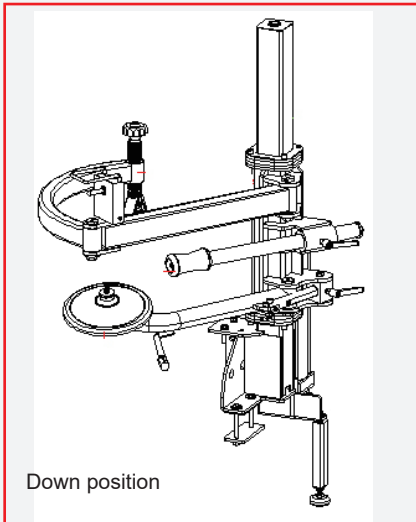

NAAR Technical Params:

- Working Pressure: 8-10bar
- Gross Weight: 40kg
- Noise during work: 70dB

Scan the code to watch the operation video

