

KOMATSU

PC290LC-11 PC290LCi-11

intelligent / 2.0
MACHINE CONTROL

EPA Tier 4 Final Engine
Australia & New Zealand Specifications



Hydraulic
excavator

NET Horsepower
147 kW / 196 HP @ 2050 rpm

Operating weight range
29,800 – 31,210 kg

Bucket capacity
0.43 – 1.39 m³

Walk-around



NET Horsepower

147 kW / 196 HP @ 2050 rpm

Operating weight

29,800 – 31,210 kg

Bucket capacity

0.43 – 1.39 m³

Photos may include optional equipment.

Performance & Durability (all models)

New engine and hydraulic control technology improves operational efficiency and lowers fuel consumption by up to 9%.

Excellent Performance and Stable Platform
A long reach arm and boom combined with a heavy duty undercarriage provides extended reach with a stable and reliable platform.

A powerful Komatsu SAA6D107E-3 engine provides a net output of 147 kW 196 HP. This engine is EPA Tier 4 Final emissions certified.

Komatsu Variable Geometry Turbocharger (KVGT) uses a hydraulic actuator to provide optimum air flow under all speed and load conditions.

Komatsu Diesel Particulate Filter (KDPF) and Selective Catalytic Reduction (SCR) system reduce particulate matter and NOx while providing automatic regeneration that does not interfere with daily operation.

Large displacement high efficiency pumps provide high flow output at lower engine speed, improving efficiency.

Komatsu's Closed-centre Load Sensing System (CLSS) provides quick response and smooth operation to maximise productivity.

Enhanced working modes are designed to match engine speed, pump delivery, and system pressure to the application.

Large LCD colour machine monitor:

- 7" high resolution screen
- Provides "Ecology Guidance" for fuel efficient operation
- Enhanced attachment control.

KomVision (standard)

Standard for PC290LCi-11
(Coming soon for PC290LC-11)

Equipment Management Monitoring System (EMMS) continuously monitors machine operation and vital systems to identify machine issues and assist with troubleshooting.

Enhanced working environment

- High back, heated air suspension seat with new adjustable arm rests
- Integrated ROPS cab design – Conforms to [ISO 12117-2 for excavators, also satisfies Level 1 operator Protective Guard [OPG] and Top guard [ISO 10262]
- AUX jack and [2] 12V power outlets.

The **Komtrax®** telematics system is standard on Komatsu equipment with no subscription fees. Using the latest wireless technology, **Komtrax®** transmits valuable information such as location, utilisation, and maintenance records to a PC or smartphone app. Custom machine reports are provided for identifying machine efficiency and operating trends. **Komtrax®** also provides advanced machine troubleshooting capabilities by continuously monitoring machine health.



Komatsu designed and manufactured components

Long arm and boom for extended reach and a heavy duty undercarriage provides stability and long life.

Handrails (standard) located on the machine upper structure provide a convenient work area in front of the engine.

Lockable single pole battery isolation switch allows a technician to disconnect the power supply before servicing the machine.

Komatsu Auto Idle Shutdown helps reduce nonproductive engine idle time and reduces operating costs.

Operator Identification System (available August 2021) can track machine operation for up to 100 operators.

Performance features

Komatsu new engine technologies

New Tier 4 Final Engine

The Komatsu SAA6D107E-3 engine is EPA Tier 4 Final emissions certified and provides exceptional performance while reducing fuel consumption. Based on Komatsu proprietary technologies developed over many years, this new diesel engine reduces particulate matter (PM) and nitrogen oxides (NOx) by 90% when compared to Tier 3 levels. Through the in-house development and production of engines, electronics, and hydraulic components, Komatsu has achieved great advancements in technology, providing high levels of performance and efficiency in virtually all applications.

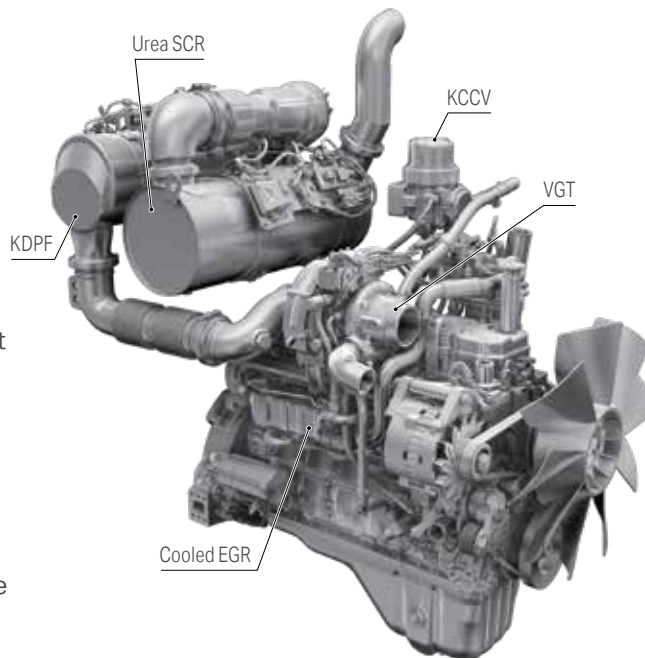

Technologies Applied to New Engine

Heavy-duty aftertreatment system

This new system combines a Komatsu Diesel Particulate Filter (KDPF) and Selective Catalytic Reduction (SCR). The SCR NOx reduction system injects the correct amount of Diesel Exhaust Fluid (DEF) at the proper rate, thereby decomposing NOx into non-toxic water vapour (H2O) and nitrogen gas (N2).



Advanced Electronic Control System

The electronic control system performs high-speed processing of all signals from sensors installed in the vehicle providing total control of equipment in all conditions of use. Engine condition information is displayed via an on-board network to the monitor inside the cab, providing necessary information to the operator. Additionally, managing the information via KOMTRAX helps customers keep up with required maintenance.

Heavy-duty cooled Exhaust Gas Recirculation (EGR) system

The system recirculates a portion of exhaust gas into the air intake and lowers combustion temperatures to reduce NOx emissions.

Furthermore, while EGR gas flow is increased, by incorporating a high-efficiency and compactly designed cooling system, the system achieves a dynamic reduction of NOx, while helping reduce fuel consumption.

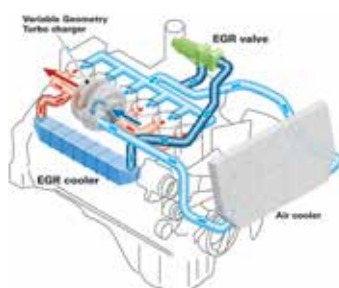

Komatsu Variable Geometry Turbocharger (KVGT) system

The VGT system features proven Komatsu designed hydraulic technology for variable control of air-flow and supplies optimal air according to load conditions. The upgraded version provides better exhaust temperature management.



Komatsu Auto Idle Shutdown

Komatsu auto idle shutdown automatically shuts the engine down after idling for a set period of time to reduce unnecessary fuel consumption and exhaust emissions.



Heavy-Duty High-Pressure Common Rail (HPCR) Fuel Injection System

The system is designed to achieve an optimal injection of high-pressure fuel by means of computerised control, providing close to complete combustion to reduce PM emissions. While this technology is already used in current engines, the new system uses high pressure injection, thereby reducing PM emissions over the entire range of engine operating conditions. The Tier 4 Final engine has advanced fuel injection timing for reduced soot levels.

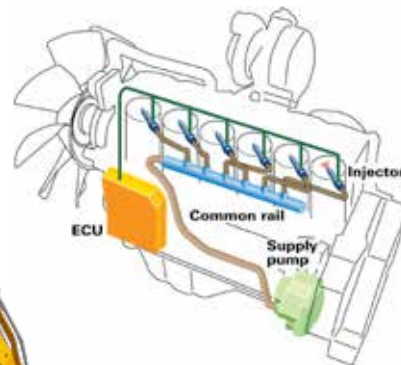

Performance features

Reduced Fuel Consumption

The PC290LC/LCi-11's new tier 4 final engine along with enhancements in the hydraulic system considerably decreases fuel consumption.

Fuel Consumption

Reduced by 9%

(vs PC270LC-8 Based on typical work pattern collected via KOMTRAX)

The fuel consumption data is the result compared actual measured value using the prototype machine. Actual fuel savings may vary depending on application and operating conditions.

Increased Work Efficiency

Functional digging force can be increased with use of the one-touch Power Max. function (up to 8.5 seconds of operation).

Maximum arm crowd force (ISO)

124 kN(16.6t) ➔ **133 kN(13.6t) 7% UP**
(With Power Max.)

Maximum bucket digging force (ISO)

184 kN(18.8t) ➔ **198 kN(23.2t) 8% UP**
(With Power Max.)

Measured with Power Max. function, 3200 mm arm and ISO rating.

Built For Productivity

The PC290LC/LCi-11 has PC300 class undercarriage components and a heavier 5200kg counterweight to deliver excellent stability and lift capability. Building on the reputation of the PC240LC-11, the PC290LC/LCi-11 offers the features below for increased digging performance in the most demanding applications.

- ① Longer Boom
- ② Longer Standard Arm
- ③ Larger Boom, Arm, and Bucket Cylinders
- ④ Greater Swing Torque
- ⑤ Larger Final Drives
- ⑥ Larger Counterweight
- ⑦ iMC 2.0 Spec Auto Tiltbucket



Efficient Hydraulic System

The PC290LC/LCi-11 uses a Closed-centre Load Sensing System (CLSS) that improves fuel efficiency and provides quick response to the operator's demands. The PC290LC/LCi-11 also incorporates new technology to enhance the engine and hydraulic pump control. This total control system matches the engine and hydraulics at the most efficient point under any load condition. There have also been improvements in the main valve and hydraulic circuit to reduce hydraulic loss, resulting in higher efficient and lower fuel consumption.



Large Displacement High Efficiency Pump

Large displacement hydraulic implement pumps provide high flow output at lower engine RPM as well as operation at the most efficient engine speed.



Working Mode Selection

The PC290LC/LCi-11 excavator is equipped with six working modes (P, E, L, B, ATT/P and ATT/E). Power Mode provides improved hydraulic power and faster cycle times for improved performance in demanding applications. Each mode is designed to match engine speed, pump flow, and system pressure to the application. The PC290LC/LCi-11 features an attachment mode (ATT/E) that allows operators to run attachments while in Economy mode.

Working Mode	Application	Advantage
P	Power Mode	Maximum production, power and multifunction
E	Economy Mode	Good cycle times with reduced fuel consumption
L	Lifting Mode / Fine Control	Increased lifting power and fine control
B	Breaker Mode	One way flow for hydraulic breaker operation
ATT/P	Attachment Power Mode	Two way flow with maximum power
ATT/E	Attachment Economy Mode	Two way flow with most efficient fuel economy

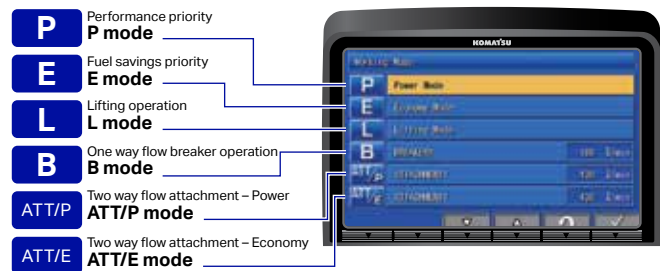

High Rigidity Work Equipment

Booms and arms are constructed with thick plates of high tensile strength steel. In addition, these structures are designed with large cross sectional areas and large one piece steel castings in the boom foot, the boom tip, and the arm tip. The result is work equipment that exhibits long term durability and high resistance to bending and torsional stress. A standard HD boom design provides increased strength and reliability.



Working environment

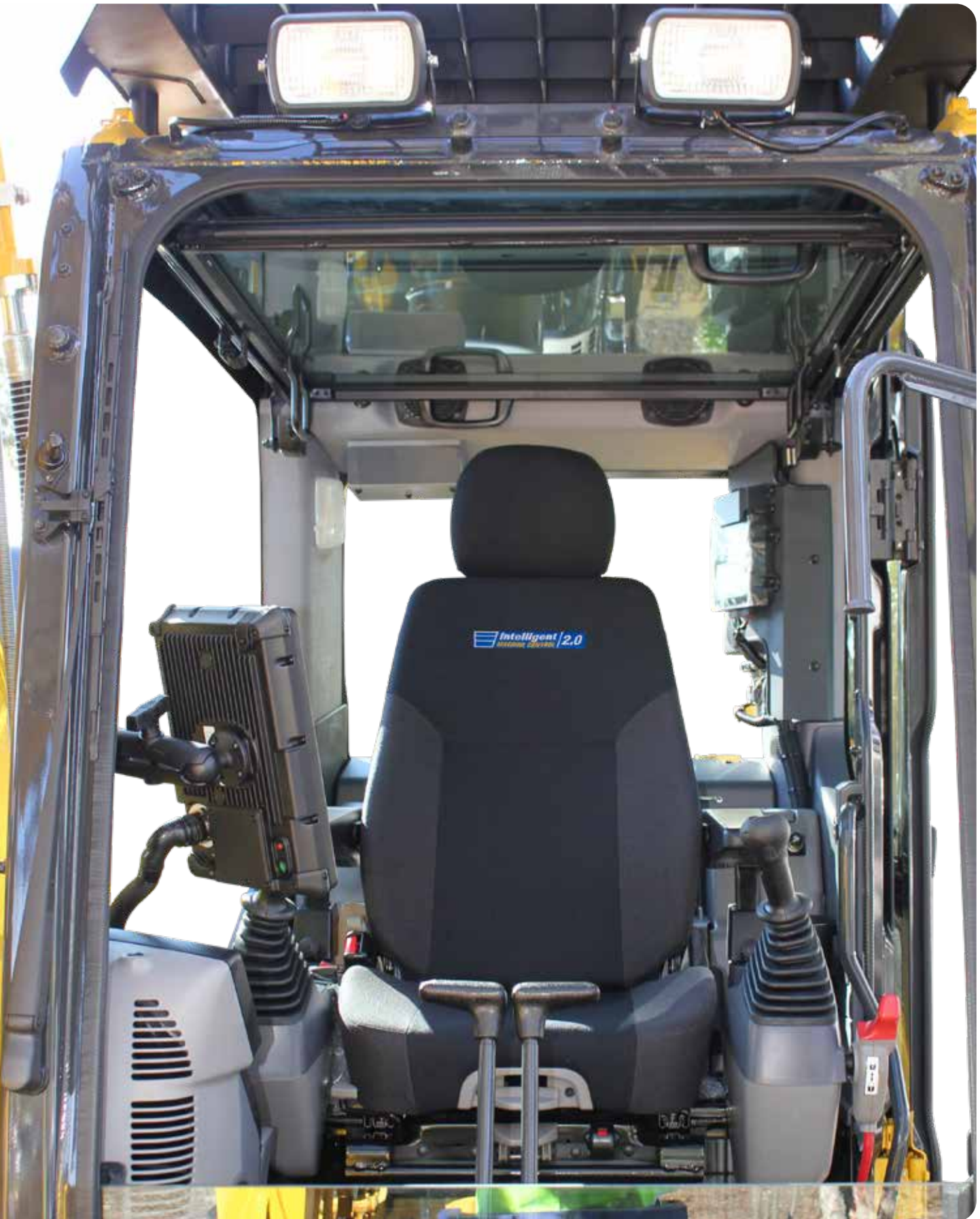



Comfortable Working Space

Wide spacious cab

The wide spacious cab includes a heated air suspension seat with reclining backrest. The seat height and position are easily adjusted using a pull-up lever. The armrest position is easily adjusted together with the console.

Arm rest with simple height adjustment function

Arm rest with simple height adjustment function. A knob and plunger on the armrests allows easy height adjustment without the use of tools.



Pressurised cab

Automatic climate control

Low vibration with cab damper mounting.

IMC 2.0 UHF & Network Antenna

ICT Antenna for UHF and Network correction service and remote support capability.



Standard Equipment

Sliding window glass (left side)



Radio, Bluetooth and USB Media System



Remote intermittent wiper with windshield washer



Emergency stop and level indicator



ISO Level 2 OPG



Magazine box and cup holder



Defroster (conforms to the ISO standard)



One-touch storable front window lower glass



Working environment

Large high resolution LCD monitor



New Monitor Panel Interface Design

An updated large high resolution LCD colour monitor enables accurate and smooth work. The interface has been redesigned to display key machine information in a new user friendly interface. A rear view camera and a DEF level gauge display have been added to the default main screen. The interface has a function that enables the main screen mode to be switched, thus enabling the optimum screen information for the particular work situation to be displayed.

Indicators

- | | |
|------------------------------------|-----------------------------|
| 1 Auto-decelerator | 8 Fuel gauge |
| 2 Working mode | 9 DEF level gauge |
| 3 Travel speed | 10 Service metre, clock |
| 4 Ecology gauge | 11 Fuel consumption gauge |
| 5 Camera display | 12 Guidance icon |
| 6 Engine coolant temperature gauge | 13 Function switches |
| 7 Hydraulic oil temperature gauge | 14 Camera direction display |
| | 15 DEF level caution lamp |

Basic operation switches

- | | |
|-------------------------|-------------------------|
| 1 Auto-decelerator | 5 Wiper |
| 2 Working mode selector | 6 Window washer |
| 3 Travel speed selector | 7 Auto climate controls |
| 4 Buzzer cancel | |

KomVision

(Standard on all models manufactured after August 2021)

Images from 4 camera's are combined to display a "birds eye" view of the area around the machine for improved operator awareness. A second display with selectable individual camera views of the left, rear, and right sides is easily changed using the F4 button. A red line continuously shows where the counterweight will be during swinging and a camera icon indicates which camera is being displayed on individual camera display screen.



Visual user menu

Pressing the F6 key on the main screen displays the user menu screen. The menus are grouped for each function, and use easy-to-understand icons which enable the machine to be operated easily.



- | | |
|---------------------------------------|-------------------|
| 1 Energy saving guidance | 4 SCR information |
| 2 Machine settings | 5 Maintenance |
| 3 Aftertreatment devices regeneration | 6 Monitor setting |
| | 7 Message check |



Support Efficiency Improvement

Ecology gauge and fuel consumption gauge

The monitor screen is provided with an ecology gauge and also a fuel consumption gauge which is displayed continuously.

In addition, the operator can set any desired target value of fuel consumption (within the range of the green display), enabling the machine to be operated with better fuel economy.



Ecology gauge | Fuel consumption gauge
Ecology guidance

Operator Identification Function

An identification ID can be set up for individual operator, application or jobs, and used to manage operation information of individual machines using KOMTRAX data. Data sent from KOMTRAX can be used to analyse operation status by operator as well as by machine.



Ecology guidance

While the machine is operating, ecology guidance pops up on the monitor screen to notify the operator of the status of the machine in real time.

Operation record, fuel consumption history, and ecology guidance record

The ecology guidance menu enables the operator to check the operation record, fuel consumption history and ecology guidance record from the ecology guidance menu, using a single touch, thus enabling the total fuel consumption to be reduced.

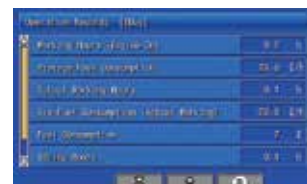

Operation record



Fuel consumption history



Ecology guidance record

intelligent machine control



Make Every Pass Count

Improve your efficiency – intelligent Machine Control means fast excavation to finish grade.

Semi-automatic operation – new features such as bucket angle hold control provide high levels of accuracy and comfort.



Innovative

- intelligent Machine Control excavator features semi-automatic operation of work equipment for highly accurate work.
- Compact 10.4" iMC monitor with increased memory capacity, processing speed, and pinch to zoom capability.

NEW

Integrated

- Complete factory-installed and integrated intelligent Machine Control system comes standard with stroke sensing hydraulic cylinders.
- Multiple Global Navigation Satellite System (multi-GNSS) components and an Inertial Measurement Unit (IMU) sensor. All components are validated to Komatsu's rigid quality and durability standards.
- Multi-band UHF/915SS radio improves job site flexibility.
- 3G/4G LTE connectivity for fast reliable job site connectivity.
- DUHF II Radio Standard fitment & 915SS Optional equipment – offers improved jobsite flexibility.

NEW

NEW

NEW

NEW

Intelligent

- Intelligent Machine Control excavator allows the operator to focus on moving material efficiently while semi-automatically tracing the target surface and limiting over-excavation.
- Facing angle compass, light bar and sound guidance aid in ease of operation and bucket positioning.
- Bucket Angle Hold and optional Auto-Tilt Attachment Control increase ease of operation and improve productivity and efficiency.

NEW





intelligent Machine Control

intelligent Machine Control is based on Komatsu's unique sensor package, including stroke sensing hydraulic cylinders, an IMU sensor, and GNSS antennas. It utilises 3D design data loaded in the control box to accurately check its position against the target. If the bucket hits the target surface, it is semi-automatically limited to minimise over-excavation. If the operator turns off Auto mode, the machine can be operated with highly accurate, responsive machine guidance (indicate only).



- **Auto grade assist**

The operator moves the arm, the boom adjusts the bucket height automatically, tracing the target surface and minimising digging too deep. This allows the operator to perform bulk excavation without worrying about the design surface, and to perform fine digging by operating the arm lever only. The working range is expanded by holding the lever to move the boom downward.



- **Auto stop control**

During boom or bucket operation, the work equipment automatically stops when the bucket edge reaches the required grade, minimising over-excavation or damage to the design surface.



- **Minimum distance control**

Bucket control automatically selects point on the bucket closest to the target surface. Even if the machine is not facing a sloped surface at a right angle, it will still follow the target surface, minimising digging below it.

intelligent machine control

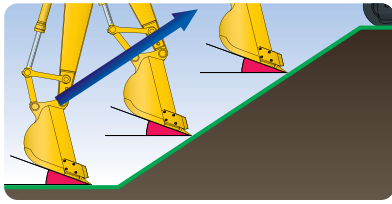

NEW

• Bucket angle hold control

Operator sets desired bucket angle and the system automatically maintains bucket angle throughout the grading pass. Angle hold control increases ease of operation and improves final grading accuracy.

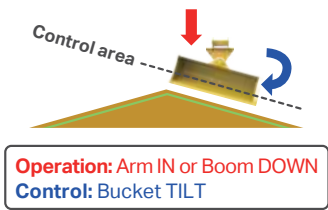

NEW

• Auto-tilt Attachment Control

Automatically tilts bucket to design surface and returns it to horizontal to unload. Using auto tilt control with the existing minimum distance control and auto grade assist makes complex grading quicker and easier.

Improved Construction Efficiency

Staking, survey and final inspection (which is usually done manually), can be reduced with the intelligent Machine Control excavator by setting 3D design data on the control box. Also, use of the facing angle compass can minimise leveling work for the surface on which the machine sits. Even if the machine is inclined while working, the facing angle compass allows the operator to ensure that the machine is facing perpendicular to the target surface. The intelligent Machine Control technology allows the operator to improve work efficiency (i.e. shorter construction time) while minimising over-excavating the target surface from rough digging to finish grading.

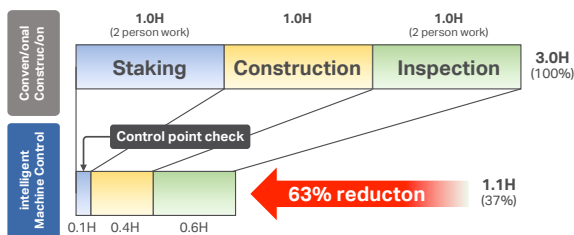

* When used by a qualified iMC operator, the Komatsu intelligent Machine Control system increases construction efficiency.
 * The above data does not include design time or working data creation time. The above data is based on in-house construction tests, performed by Komatsu, whose conditions may differ from actual construction.

Improved Work Accuracy

The bucket edge/tip position is instantly displayed on the control box, eliminating the wait time for display on the monitor during construction. The large and easy-to-view control box displays information clearly, aiding in highly accurate work. With manual operation and conventional machine guidance, finish grade quality and excavating accurately depends heavily on the skill of the operator. With the intelligent Machine Control excavator, the bucket is automatically limited to follow the target grade without over-excavating.

Relationship Between Finished Surface and Allowable Value

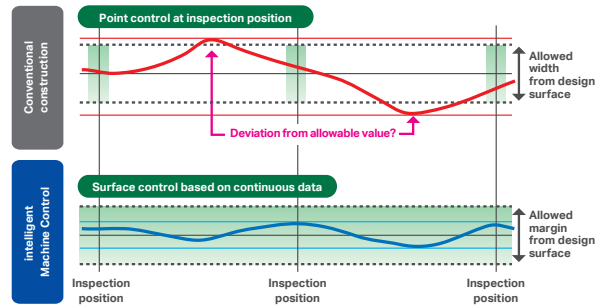

As-Built Surface Mapping

Operator can display and check the as-built status and find where to cut and fill.

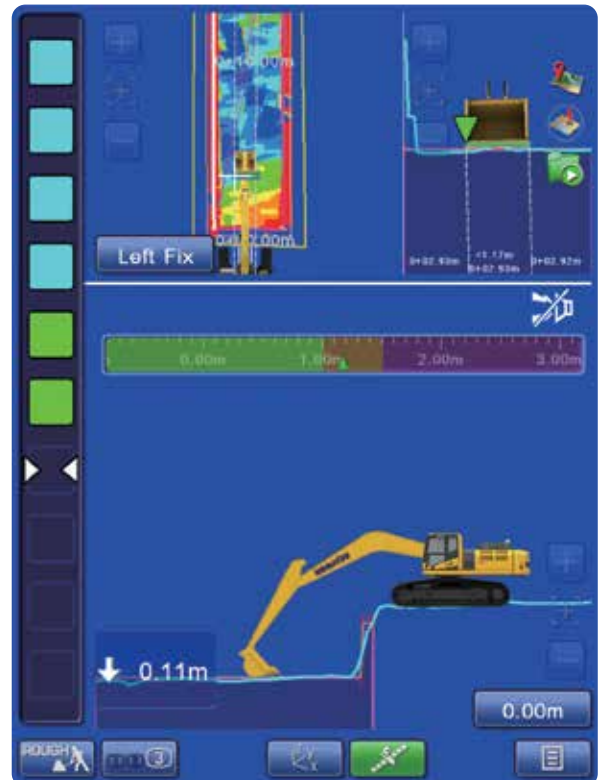

Control box

The monitor of the Komatsu intelligent Machine Control (control box) uses a compact 10.4" screen for visibility and ease of use. The simple screen layout displays the necessary information in an easily understood fashion. Touch screen icon interface instead of multi-step menu simplifies operation.



Preset Elevation Offset Quick Button +0.500'

Pre-determined offsets can be stored in the monitor to allow an operator to easily switch between preset grades. NEW

Offset preset	0.000'	Apply
	0.500'	Apply
	1.500'	Apply

Button switch mode Offset preset

Quick Bucket Swap Button NEW

Allows users to quickly swap between various buckets without having to enter main menu. This lessens the time a user takes to change out a bucket on the monitor.

Machine Navigation

Facing angle compass

The orientation and colour of the facing angle compass's arrow shows the operator the facing angle of the bucket edge relative to the target surface.



This allows the bucket edge to be accurately positioned square with the target surface, which is useful when finishing slopes.

Enhanced operability of the machine control NEW

Semi-auto/manual mode switching and design surface offset function can be operated with switches on the control levers.



intelligent machine control

Factory installed Komatsu intelligent Machine Control components



Standard Local Options providing first 12 months support:

(includes: Standard 3G/4G modem with DATA & SIM, industry leading ICT machine OEM service support agreement with iMC 2.0)



Remote control

Assist the operator by taking control of their GNSS equipment in real-time.



File transfer history

Overview of when, and which, files have been transferred.



Remote view

Real-time remote image of the GNSS equipment.



Office to machine transfer

Send the latest design files from the office to your machines.



Machine to office transfer

Download files that have been collected on your system (survey results, as-built data, ...)



Offline file transfer

Machine offline? No issue. Files are stored in cloud, operator will see updated model at machine switch on.

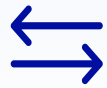

Batch file transfer

Send files to multiple machines in one click.



Work smarter from rough digging to finish grade

Give your operators the power to work more effectively than with conventional aftermarket machine guidance (indicate only) or manual operation. Intelligent Machine Control (iMC) excavators with semi-automatic control offer the capability to work smart from rough digging to finish grading, and help minimise over-excavation to make every pass count.

- Semi-automatic for trenching, slope work and high production applications
- Protection + precision + performance = the formula for pursuing maximum productivity versus conventional machine guidance



Intelligent machine control

Working smarter in every way

Benefits of iMC 2.0



Save money

Frees GPS Dozer from need to achieve final grade so it can work elsewhere on the site.



Save time

Reduce staking, grading and inspection with 3D design data and semi-automatic grading.

Photo may include overseas specification.
PC360LCi-11 shown.



Less time grade checking

Monitor performance and stay on grade from the cab: operators spend time working, not grade checking.



Improve accuracy

Continuously monitor grade and semi-automatics to dig precisely to grade.

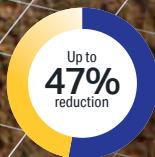

Reduce base aggregate

Greatly reduce over-digging and the amount of costly base aggregate needed for applications like utilities.

**All savings, improvements, and reductions are compared to traditional grading methods.*

Maintenance features



Maintenance features

Large capacity air cleaner

The larger air cleaner can extend air cleaner life during long-term operation and helps prevent early clogging, and resulting power loss. A radial seal design is used for reliability.



Engine Access

Large rear opening hood provides excellent maintenance and service access to key engine components.



Fuel Filters

Large high-efficiency fuel filter and pre-filter with water separator removes contaminants from fuel for improved fuel injection system life.



High efficiency fuel filter Fuel pre-filter (with water separator)

Easy access to engine oil filter and fuel drain valve

Engine oil filter and fuel drain valve are remote mounted to improve accessibility.

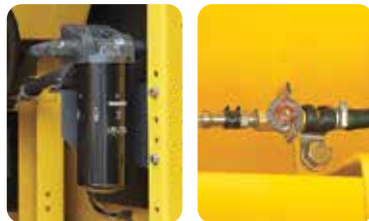

Battery isolation switch

A standard battery isolation switch allows a technician to disconnect the power supply and lock out before servicing the machine.



Air conditioner filter

The air conditioner filter can be removed and installed without the use of tools for easy filter maintenance.

- Washable cab floormat**
- Sloping track frame**
- Long-life oils, filters**

Engine oil & Engine oil filter	every 500 hours
Hydraulic oil	every 5000 hours
Hydraulic oil filter	every 1000 hours

DT-type connectors

Sealed DT-type electrical connectors provide high reliability, water and dust resistance.

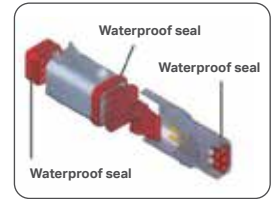

Diesel Exhaust Fluid (DEF) tank

A large tank volume extends operating time before refilling and is installed on the right front platform for easy access. DEF tank and pump are separated for improved service access.



Maintenance information

"Maintenance time caution lamp" display

When the remaining time to maintenance becomes less than 30 hours*, a maintenance time monitor appears. Pressing the F6 key switches the monitor to the maintenance screen.

*: The setting can be changed within the range between 10 and 200 hours.



Maintenance screen

Manual Stationary Regeneration

Under most conditions, active regeneration will occur automatically with no effect on machine operation. In case the operator needs to disable active regeneration or initiate a manual stationary regeneration, this can be easily accomplished through the monitor panel. A soot level indicator is displayed to show how much soot is trapped in the KDPP.

Soot level indicator



Aftertreatment device regeneration screen

Supports the DEF level and refill timing

The DEF level gauge is displayed continuously on the right side of the monitor screen. In addition, when DEF level is low, DEF low level guidance messages appear in pop up displays to inform the operator in real time.



DEF level gauge

DEF low level guidance

KALSS

Australian standard specification



Rotating Amber Beacon
Fitted with factory guard.



Level Indicator, Overload Alarm & Anti-Burst Valves
Enable safety and compliance when lifting suspended loads.



Additional Lighting
Extra lighting on cab and counterweight for improved visibility.



Proportional Hand Controls
Enables proportional hand control of attachment speed.



Bump Rails
For upper protection when slewing.

Higher Capacity Air Conditioner
With increased cool down performance.

Factory Fitted Quick Hitch and Hammer Piping
Enables use with a greater variety of attachments. Also fitted with provision for tilt circuit including valve.

Revolving Frame Under Covers
Protects and prevents ingress of material into engine bay.

Rock Guard
Reinforced steel plate and ribs to provide additional protection of arm structure.



Lower Front Window Guard
Protects cabin windscreen against rocks and debris.



Battery Isolation
Single pole, lockable Bosch-type battery isolation.



E-Stops
Allow compliance to site safety requirements.



Bolt-on Top Guard
OPG level 2 (ISO 10262) for falling object protection.

Specification also includes factory fitted provisions for fire extinguisher, turbo timer, UHF and vandal covers to reduce lead times and costs. Photos may include optional equipment.

KALSS for IMC 2.0

Australian standard specification



NEW

Control box
A large, easy-to-view monitor designed for Komatsu intelligent Machine Control.

Proportional control levers

NEW

Multi-GNSS antenna

Stroke sensing hydraulic cylinder
A stroke sensor is built into the cylinder. This sensor provides accurate, real time bucket position which is immediately displayed on the control box, speeding up your work.

Inertial Measurement Unit (IMU)
High accuracy in the finishing work is secured by Inertial Measurement Unit (IMU) detecting the machine posture.

NEW
Multi-GNSS receiver

Auto-tilt Attachment Control

Standard iMC Specification included	iMC 1.0	iMC 2.0
3G/4G Modem (remote/network)	✓	✓
DUHF II and Network Antenna	✓	✓
Auto-Tilt Attachment (IMU Kit)		✓
DUHF II – Digital UHF II radio Board	✓	✓
SC Service Level Agreement	✓	✓
Bucket Angle Hold		✓

KOMTRAX equipment monitoring

Get the whole story with



What

- KOMTRAX is Komatsu's remote equipment monitoring and management system. KOMTRAX continuously monitors and records machine health and operational data.
- Information such as fuel consumption, utilisation, and a detailed history lowering owning and operating cost.

Who

- KOMTRAX is standard equipment on all Komatsu construction products.

When

- Know when your machines are running or idling and make decisions that will improve your fleet utilisation.
- Detailed movement records ensure you know when and where your equipment is moved.
- Up to date records allow you to know when maintenance is due and help you plan for future maintenance needs.

Where

- KOMTRAX data can be accessed virtually anywhere through your computer, the web or your smart phone.
- Automatic alerts keep fleet managers up to date on the latest machine notifications.

Why

- Knowledge is power – make informed decisions to manage your fleet better.
- Knowing your idle time and fuel consumption will help maximise your machine efficiency.
- Take control of your equipment – any time, anywhere.



KOMTRAX
For construction and compact equipment.

KOMTRAX Plus
For production and mining class machines.

Specifications

Engine

Model	Komatsu SAA6D107E-3*
Type	Water-cooled, 4-cycle, direct injection
Aspiration	Variable geometry turbocharged, aftercooled, cooled EGR
Number of cylinders	6
Bore	107 mm 4.21"
Stroke	124 mm 4.88"
Piston displacement	6.69 ltr 408 in ³
Horsepower:	
SAE J1995	Gross 159 kW 213 HP
ISO 9249 / SAE J1349	Net 147 kW 196 HP
Rated rpm	2050
Governor	All-speed control, electronic
Fan drive method for radiator cooling	Mechanical

*EPA Tier 4 Final emissions certified

Hydraulics

Type	HydrauMind (Hydraulic Mechanical Intelligence system, closed-centre system with load sensing valve and pressure compensated valves)		
Number of selectable working modes	6		
Main pump:			
Pumps for	Boom, arm, bucket, swing, and travel circuits		
Type	Variable displacement axial piston type		
Maximum flow	535 ltr/min 141.3 gal/min		
Supply for control circuit	Self reducing valve		
Relief valve setting:			
Implement circuits	37.3 MPa	5380 kgf/cm²	5,400 psi
Travel circuit	37.3 MPa	5380 kgf/cm²	5,400 psi
Swing circuit	27.9 MPa	5285 kgf/cm²	4,050 psi
Pilot circuit	3.2 MPa	533 kgf/cm²	470 psi
Hydraulic cylinders:			
(Number of cylinders – bore x stroke x rod diameter)			
Boom	2–140 mm x 1480 mm x 100 mm	5.5" x 58.3" x 3.9"	
Arm	1–160 mm x 1825 mm x 110 mm	6.3" x 71.9" x 4.3"	
Bucket	1–140 mm x 1285 mm x 100 mm	5.5" x 50.6" x 3.9"	

Drives and brakes

Steering control	Two lever with pedals
Drive method	Hydrostatic
Maximum drawbar pull	290 kN 29570 kgf 65,191 lbf
Gradeability	70%, 35°
Maximum travel speed (auto shift):	
High	5.5 km/h 3.4 mph
Mid	4.2 km/h 2.8 mph
Low	3.2 km/h 2.0 mph
Service brake	Hydraulic lock
Parking brake	Mechanical disc brake

Swing system

Drive method	Hydrostatic
Swing reduction	Planetary gear
Swing circle lubrication	Grease-bathed
Service brake	Hydraulic lock
Holding brake/Swing lock	Mechanical disc brake
Swing speed	10.5 rpm
Swing torque	8889 kg•m 64,292 ft lbs

Undercarriage

Centre frame	X-frame
Track frame	Box-section
Seal of track	Sealed track
Track adjuster	Hydraulic
Number of shoes (each side)	48
Number of carrier rollers (each side)	2
Number of track rollers (each side)	8

Coolant & lubricant capacity (Refilling)

Fuel tank	400 ltr	105.7 U.S. gal
Coolant	36 ltr	9.5 U.S. gal
Engine	23.1 ltr	6.1 U.S. gal
Final drive, each side	8.0 ltr	2.1 U.S. gal
Swing drive	7.2 ltr	1.9 U.S. gal
Hydraulic tank	132 ltr	34.9 U.S. gal
Hydraulic system	253 ltr	66.8 U.S. gal
DEF tank	23.1 ltr	6.1 U.S. gal

Operating weight (approximate)

Operating weight includes **6150 mm** one-piece HD boom, **3200 mm** HD arm, rated capacity of lubricants, coolant, full fuel tank, operator, standard equipment, KGA dual lock quick hitch, and SAE heaped **1.39 m³** bucket.

Triple-grouser shoes	Operating weight	Ground pressure
600 mm	30,330 kg	0.58 kg/cm²
700 mm	30,730 kg	0.50 kg/cm²
800 mm	31,130 kg	0.45 kg/cm²

Component weights

Arm including bucket cylinder and linkage:		
2500 mm HD arm assembly	1410 kg	3,108 lb
3200 mm HD arm assembly	1470 kg	3,240 lb
3500 mm HD arm assembly	1550 kg	3,417 lb
One piece HD boom including arm cylinder:		
6150 mm boom assembly	2448 kg	5,397 lb
Boom cylinders x 2	231 kg	509 lb
Counterweight (standard)	5200 kg	11,464 lb

Dimensions

	Arm Length	3200 mm	2500 mm	3500 mm
A	Overall length	10265 mm	10317 mm	10275 mm
B	Length on ground (transport)	5770 mm	6628 mm	5495 mm
C	Overall height (to top of boom)*	3295 mm	3367 mm	3375 mm
D	Overall width	3190 mm		
E	Overall height (to top of cab)*	3180 mm		
F	Overall height (to top of handrail)*	3275 mm		
G	Ground clearance, counterweight	1215 mm		
H	Ground clearance, minimum	495 mm		
I	Tail swing radius	3020 mm		
J	Track length on ground	4030 mm		
K	Track length	4955 mm		
L	Track gauge	2590 mm		
M	Width of crawler	3190 mm		
N	Shoe width	600 mm		
O	Grouser height	36 mm		
P	Machine height to top of counterweight	2380 mm		
Q	Machine height to top of engine cover	2895 mm		
R	Machine upper width	2850 mm		
S	Distance, swing centre to rear end	2985 mm		

* Including grouser height

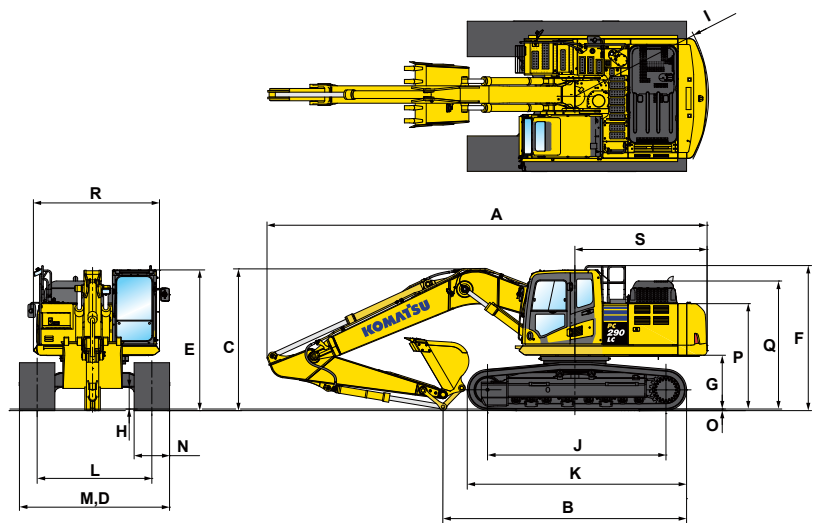

Working range

	Arm Length	3200 mm	2500 mm	3500 mm
A	Max. digging height	10300 mm	9840 mm	10355 mm
B	Max. dumping height	7375 mm	6972 mm	7435 mm
C	Max. digging depth	6910 mm	6208 mm	7220 mm
D	Max. vertical wall digging depth	5790 mm	4314 mm	5850 mm
E	Max. digging depth for 8' level bottom	6750 mm	6008 mm	7070 mm
F	Max. digging reach	10710 mm	9957 mm	10890 mm
G	Max. digging reach at ground level	10450 mm	9763 mm	10715 mm
H	Min. swing radius	3680 mm	3722 mm	3740 mm
SAE rating:				
Bucket digging force at power max.		176 kN	176 kN	176 kN
		17900 kg	17900 kg	17900 kg
Arm crowd force at power max.		129 kN	165 kN	121 kN
		13100 kg	16800 kg	12400 kg
ISO rating:				
Bucket digging force at power max.		198 kN	198 kN	198 kN
		20200 kg	20200 kg	20200 kg
Arm crowd force at power max.		133 kN	170 kN	125 kN
		13600 kg	17300 kg	12800 kg

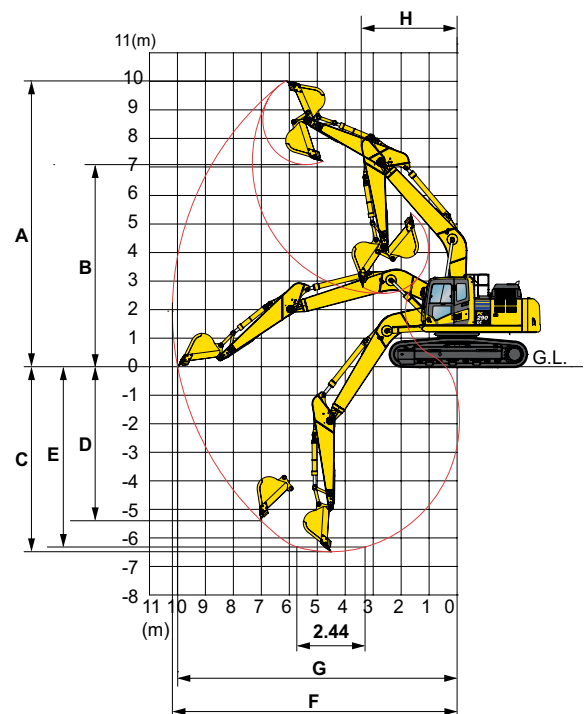

Lift capacities

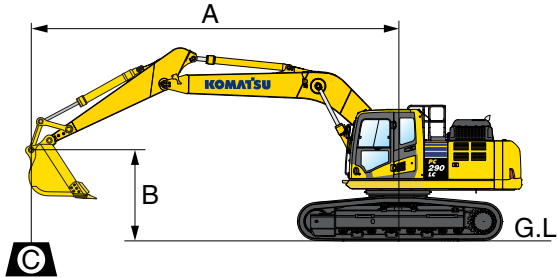

Lifting capacity with lifting mode

A:	Reach from swing centre
B:	Bucket hook height
C:	Lifting capacity
Cf:	Rating over front
Cs:	Rating over side
⊗:	Rating at maximum reach

Conditions:

Boom length:	6150 mm
Arm length:	3200 mm
Shoes:	600 mm triple grouser
Bucket:	808 kg

A/B	1.5 m		3.0 m		4.5 m		6.0 m		7.5 m		Unit: kg ⊗ MAX	
	Cf	Cs	Cf	Cs	Cf	Cs	Cf	Cs	Cf	Cs	Cf	Cs
6.0 m	-	-	-	-	-	-	-	-	*5600	5300	*3400	*3400
4.5 m	-	-	-	-	-	-	*7150	*7150	*6350	5150	*3450	*3450
3.0 m	-	-	*8850	*8850	*11100	*11100	*8400	7100	*7150	4950	*3650	3500
1.5 m	-	-	-	-	*13800	10400	*9750	6700	7550	4750	*3950	3350
0 m	-	-	*8150	*8150	*15100	9900	10500	6400	7350	4550	*4550	3400
-1.5 m	*8250	*8250	*9750	*9750	*15200	9700	10350	6250	7250	4450	*5550	3700
-3.0 m	*10700	*10700	*16500	*16500	*14550	9750	10300	6200	7250	4450	6950	4250
-4.5 m	-	-	*17800	*17800	*12800	9950	*9450	6350	-	-	*8100	5650

* Load is limited by hydraulic capacity rather than tipping. Ratings are based on SAE standard No. J1097.
Rated loads do not exceed 87% of hydraulic lift capacity or 75% of tipping load.



Standard equipment

- 3 speed travel with auto shift
- Access handrails – counterweight
- Alternator, 90 A, 24 V
- Arm, 3200 mm
- Auto idle
- Auto idle shut down
- Automatic air conditioner, large capacity
- Automatic engine warm-up system
- Auxiliary input (3.5 mm jack)
- Batteries, large capacity
- Battery isolation switch, lockable
- Boom, 6150 mm
- Boom and arm burst valve protection
- Bump rails
- Cab guards
 - Lower front window guard
 - Integrated top guard, OPG Level 1
 - Bolt on top guard, OPG Level 2
- Carrier rollers, (2 each side)
- Converter, (2) x 12 V
- Counterweight, 5200 kg
- Dry type air cleaner, double element
- Dual flow hammer piping
- Electric horn
- Emergency stops (3)
- EMMS monitoring system
- Engine, Komatsu SAA6D107E-3
- Fan guard structure
- Fire extinguisher, 1.5 kg (for PC290LCi-11)
- Fuel system pre-filter 10 micron
- Guard belly plate (for PC290LCi-11)
- High back air suspension seat, with heat
- High pressure in-line hydraulic filters
- Hydraulic track adjusters
- HydraMind closed centre load sensing system
- KOMTRAX
- Komvision (Standard on all models manufactured after August 2021)
- Large LCD colour monitor, high resolution
- Level indicator
- Lock lever
- Lock lever, auto-lock
- Mirrors (LH, RH & sidewise)
- Operator identification system (available August 2021)
- Overload alarm
- Power maximising system
- PPC hydraulic control system
- Proportional control handles
- Provision for tilt circuit, including valve
- Pump/engine room partition cover
- Quick hitch piping with safety switch and alarm
- Radiator and oil cooler dustproof net
- Radio Bluetooth USB media system
- Rear reflectors
- Revolving frame undercovers
- ROPS cab (ISO 12117-2) with vandal guard provisions
- Rearview monitoring system (1 camera) (For PC290LC-11 models manufactured before August 2021)
- Rotating beacon (LED) with guard
- Seat belt indicator
- Seat belt, retractable, 78 mm
- Secondary engine shutdown switch
- Side access hand rails
- Side by side coolers
- Slip resistant foot plates
- Starter motor, 5.5 kW/24 V x 1
- Suction fan
- Thermal and fan guards
- Track roller guides, 3 each side
- Track rollers, 8 each side
- Track frame swivel guard
- Track shoes, triple grouser, 600 mm
- Travel alarm
- Turbo timer
- Working lights
 - 1 x boom
 - 1 x RH
 - 3 x cab
 - 1 x counterweight
- Working mode selection system

intelligent Machine Control

- 12 month remote access to your machine (includes data & SIM)
- 12 months service level support agreement
- Auto grade assist
- Auto stop control boom and bucket
- Auto tilt attachment control [when tilt bucket fitted]
- Bucket angle hold
- Dual multi-constellation GNSS antennas
- Excavator weighing system
- Factory integrated 3D machine control
- iMC 2.0 canvas seat cover
- Komatsu chassis mounted iMU
- Komatsu PH700 monitor
- Komatsu stroke sensors [boom/arm & bucket]
- MC-i4 with internal 4G modem
- Minimum distance control
- Network and UHF antennas
- Receiver- UR-1 UHF and 915SS radio

Optional equipment

- Arm, 2500 mm
- Arm, 3500 mm
- Autogrease system
- Battery isolation switch, dual pole, lockable
- Cab guard – Full front guard, OPG Level 2
- Cab vandal guard set
- Canvas seat cover (for PC290LC-11)
- Fire extinguisher, 1.5 kg (for PC290LC-11)
- Fire extinguisher, 4.5 kg
- Fire extinguisher, 9 kg
- Fuel cap vandal guard
- Guard belly plate (for PC290LC-11)
- Jump start receptacle
- Komvision – PC290LC-11 (units with rearview monitor)
- Radio, UHF (for PC290LC-11)
- Starter circuit isolation, lockable
- Track roller guards, full length
- Track shoes, triple grouser, 700 mm
- Track shoes, triple grouser, 800 mm
- Window tinting

Attachment options

- Bucket, general purpose, KGA 600 mm, 0.43 m³
- Bucket, general purpose, KGA 900 mm, 0.75 m³
- Bucket, general purpose, KGA 1200 mm, 1.08 m³
- Bucket, general purpose, KGA 1500 mm, 1.39 m³
- Bucket, slope finishing, KGA 2000 mm, 1.64 m³
- Quick hitch, KGA, dual lock
- Quick hitch, KGA, dual lock, tilting
- Ripper, KGA, single tyne

Now available

Komatsu JMHB230V-1 Hydraulic Breaker



Model Type	JMHB230V-1	
Working weight	kg	1,450
Oil flow (min - max)	ℓ /min	120 - 170
Operating pressure (max)	MPa	135
Impact rate	bpm	285 - 1,050
Chisel diameter	mm	122
Acceptable back pressure	bar	8
Base machine (min - max)	Ton	18 - 30

For a complete list of available attachments, please contact your local Komatsu representative.

Product designs, specifications and/or data in this document are provided for informational purposes only and are not warranties of any kind. Product designs and/or specifications may be changed at any time without notice. The only warranties that apply to sales of products and services are Komatsu's standard written warranties, which will be furnished upon request.

Komatsu and other trademarks and service marks used herein are the property of Komatsu Ltd., Komatsu Australia Pty Ltd., Komatsu America Corp., Komatsu Mining Corp., or one of their affiliates, or the respective owners or licensees.

KOMATSU

[komatsu.com.au](https://www.komatsu.com.au)

