

Dado Single Round Accessible



DDR1-D



Scan QR code to view our installation notes



Product Info:

- Choice of accessible and compact (p.272) models
- Accessible model = AS1428 compliant
- Front push, timed flow bubbler
- 40mm waste and stainless wall bracket
- Optional bottle filler tap
- Optional remote refrigeration unit
- Commercial grade 304 S.S.

To order this item please advise:

- Ambient or refrigerated water
- If bottle filler tap is required

Suggested Bottle Filler Option:



TW-BF-HF
Fixed Spout Bottle Filler Hob Mounted

ACCESSORIES

74-08-0106
Replacement Battery Pack for Activation Button

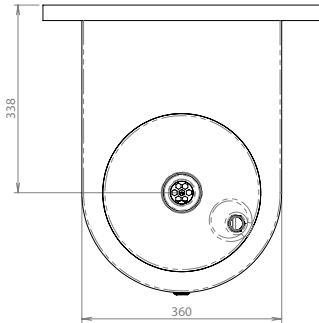

INSTALLATION NOTES

1) Fixture strength is ultimately determined by the load capacity of the supporting structure (noggins recommended for stud walls) and use of appropriate fixings (i.e. sleeve anchors for masonry walls). **2)** Fountain is secured to wall at the top of the splashback with an offset bracket (supplied) and with an L-shaped, angle bracket (supplied) concealed behind the bottom of the splashback. **3)** Trap and fixings (other than wall bracket) not supplied. **4)** Water connection to 1/2" solenoid: min = 150kPa, max = 500kPa. **5)** An in-line filter to prevent debris fouling solenoid is recommended.

Refrigerated model: **1)** supplied with remote chiller to be installed in wall cavity behind fountain. **2)** 10 amp standard power outlet required. **3)** Single water connection to chiller is 1/2" female BSP, min = 250kPa, max = 500kPa.

