

Wire Rope Hoist / Builders Hoist

Features:

- Auto stop feature
- Heavy duty construction
- Scaffolding safety latch
- 240 volt 3 pin plug power supply
- 7mtr pendant length

Specifications:

- Duty Cycle: 25%
 - Power Supply: 220-240 V
 - Insulation Class: F
 - Lift: 30 mtr lift
- | Model | Capacity | Lift |
|-----------|----------|------|
| EW-TBH250 | 250kg | 30m |
| EW-TBH360 | 360kg | 60m |
| EW-TBH500 | 500kg | 30m |

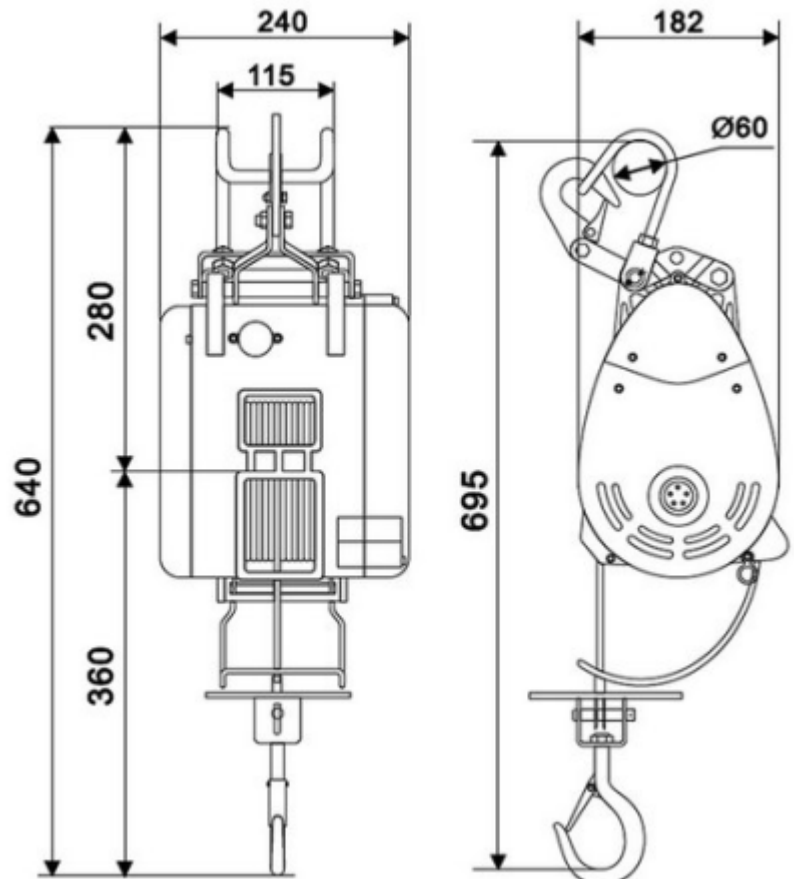

Equipment Warehouse Pty Ltd

Phone No: 1800-700999 | www.equipmentwarehouse.com.au | info@equipmentwarehouse.com.au

Sydney - Brisbane - Melbourne - Adelaide - Perth

SPECIFICATIONS SUBJECT TO CHANGE WITHOUT NOTICE