



1.4T Walkie Reach Stacker 3.8m (Compact)

H14WRC38

Load capacity
1.4 tonne



Collapsed height
1.910m



Lift height
3.8m



Manoeuvrability



Ease of use





The Hyworth 1.4T Walkie Reach Stacker (Compact) is a versatile machine that offers all the top benefits of a forklift in a compact, stacker size - without needing a forklift license.

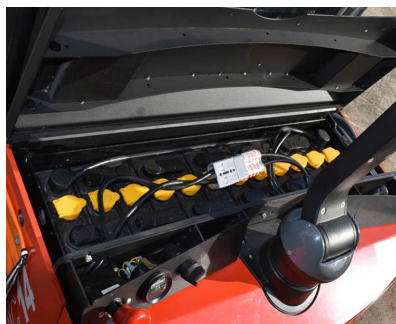

The Hyworth 1.4T Walkie Reach Stacker (Compact) is your key to navigating tight aisles.

This machine can manoeuvre within a minimum aisle width of 2750mm rack to rack or 2450mm pallet to pallet and reach racking up to the high level of 3600mm top beam.

Compact and highly versatile, the Walkie Reach Stacker can adapt to many applications. Whether requiring assistance in retail storage, warehousing and distribution, truck side-loading, transport or logistics, this machine can handle various operations efficiently.

The Hyworth 1.4T Walkie Reach Stacker (Compact) is the perfect machine for a growing business where staff are not licensed to operate ride-on forklifts. Equipped with a retractable scissor reach fork extension system and the ability to handle different pallets, these electric-powered Walkie Reach Stackers can save space and increase efficiency in all operations. This model also comes standard with side-shift and moonwalk features as a bonus.

Compact

With an aisle width of only 2750mm rack-to-rack, this machine can easily fit between narrow aisles.

Manoeuvrable

With its advanced moonwalk function, the Walkie Reach Stacker is perfect for navigating narrow aisles and tight spaces.

Ultimate control

This machine has an AC drive system which is more efficient and longer lasting than a DC motor, enabling smooth and progressive control.

Improved load positioning

The side-shift function enables the operator to accurately position the load on the pallet or container, reducing the risk of damage or accidents.

Increased efficiency

Handle various loads and increase productivity with advanced features, electronic controls and versatile capabilities.

Ergonomic operation

Reduce fatigue and improve productivity with variable fingertip controls designed for comfort and safety.

Safety & Ergonomics

Auto park brake - Ensures the vehicle is safely parked at a stop on all inclines by automatically restricting the rotation of the wheels.

Emergency reverse button - Prevents the operator from being crushed in tight environments by enabling quick reversing in an emergency.

Anti-sliding function - Reduce the risk of accidents and injuries, increasing operator confidence with a safe and secure platform.

Automatic speed reduction on steer lock - Avoid tipping with functions to automatically reduce the forklift's speed when the steering wheel is turned to its maximum position.

Automatic speed reduction on 2nd stage lift - Maintain stability with functions to automatically reduce the forklift's speed when the load is elevated.

Mast intelligent lowering buffer - Reduce risks of dropping or damaging the load by ensuring a controlled and smooth descent.

Efficiency & Productivity

Electric power steering - Handle the forklift with minimal effort, more precise control, and enhanced manoeuvrability in tight spaces.

Stepless Speed Controls - allows the smooth transition of traction speed adaptable to the operator's walking pace.

Standard with moonwalk function - Operate with a clear line of sight when moving in reverse.

Powerful AC drive system - Optimise power usage and move heavier loads more efficiently by adjusting the motor speed to your load requirement.

Standard with side-shift - Enhance operational efficiency and safety by aligning the load accurately without requiring manual adjustment.

Multi-function tiller arm - Increase efficiency by controlling steering, acceleration, lifting, lowering, and tilting from one centralised location.

Serviceability & Reliability

Curtis AC control - Optimise performance and efficiency with an AC motor controller for smooth acceleration, deceleration and precise speed.

Maintenance-free AC travel motor - Reduce maintenance costs and downtime with an efficient and reliable AC motor, requiring little to no maintenance over its lifespan.

Easy access componentry - Save time and money with efficient and convenient access to components during maintenance or servicing.

CANBUS diagnostics - Immediately access critical information, including real-time motor performance, battery status, and hydraulic system operation.

Advanced battery monitoring - Never operate beyond the battery's capacity with a built-in battery indicator, timer and fault self-diagnosis meter providing real-time data.

High-performance suspension load wheels - Seamlessly adjust to uneven surfaces and obstacles whilst keeping the load stable.



Features

Safety/ergonomics

Electric power steering	Included
Side-shift function	Included
Moonwalk function	Included
Compact design	Included
Load guard options	<i>Optional</i>
Flashing light	<i>Optional</i>
Blue safety light	<i>Optional</i>
Rubber gutter ramp	<i>Optional</i>



Efficiency/productivity

AC drive system	Included
Stepless speed control	Included
Sideshift	Included
Moonwalk	Included
Reach & tilt functionality	Included
Multifunction tiller arm	Included
Regenerative braking	Included
Slipper extensions	<i>Optional</i>
Longer fork tynes	<i>Optional</i>

Serviceability/reliability

Curtis AC control system	Included
CANBUS diagnostics	Included
Brushless and maintenance-free AC travel motor	Included
Built-in battery indicator, timer and fault self-diagnosis meter	Included
Easy access componentry for maintenance	Included
High-performance suspension load wheels	Included





Warning signs on the mast: a no-smoking symbol and a no-open flames symbol.

HYWORTH

HYWORTH

14

Technical Specifications

Walkie Reach Stacker Compact Specification

Distinguishing marks	1.1	Manufacturer		HYWORTH
	1.2	Manufacturer's model number		H14WRC
	1.3	Power type		Battery Electric
	1.4	Operator type		Walk Behind Pedestrian
	1.5	Rated capacity/rated load	Q (kg)	1400
	1.6	Load centre distance	c (mm)	600
	1.7	Load distance, centre of drive axle to fork	x (mm)	379
	1.8	Wheelbase	y (mm)	1478
Weights	2.1	Service weight without battery	kg	1990
Wheels, Chassis	3.1	Tyres:solid rubber,superelastic,pneumatic,polyurethane		PU
	3.2	Tyre size, front	mm	Φ250×100
	3.3	Tyre size, rear	mm	Φ100×70
	3.4	Wheels, number front / rear (x = driven wheels)		1×4
	3.5	Tread, rear	b ₁₁ (mm)	1170
Basic Dimensions	4.1	Tilt of mast forward/backward	α/β(°)	4/3
	4.2	Height, mast lowered	h ₁ (mm)	1910 / 2235 / 2570
	4.3	Lift	h ₃ (mm)	3800 / 4500 / 5500
	4.4	Height, mast extended	h ₂ (mm)	4785 / 5685 / 6685
	4.5	Height of tiller in drive position min./max.	h ₁₄ (mm)	755
	4.6	Height of wheel arms	h ₈ (mm)	130
	4.7	Height, lowered	h ₁₃ (mm)	55
	4.8	Overall length	l ₁ (mm)	2225 ¹⁾
	4.9	Length to face of forks	l ₂ (mm)	1253 ¹⁾
	4.10	Overall width	b (mm)	1430
	4.11	Fork dimensions	s/e/l (mm)	40/100/1070
	4.12	Fork-carriage width	b ₃ (mm)	920
	4.13	Distance between fork-arms	b ₁ (mm)	200-755
	4.14	Distance between wheel arms	b ₄ (mm)	1070-1270 ²⁾
	4.15	Reach distance	l ₃ (mm)	600
	4.16	Ground clearance, centre of wheelbase	m ₂ (mm)	48.5
	4.17	Turning radius	W _a (mm)	1566
	4.18	Length across wheel arms	l ₇ (mm)	1777
	4.19	Battery compartment width	l ₈ (mm)	340
	4.20	Battery compartment length	b ₆ (mm)	817
	4.21	Battery floor Height w/optional rollers	(mm)	240
	4.22	Load backrest height	h ₁₂ (mm)	1050
	4.23	Grade clearance	D(%)	46.57
	4.24	Minimum aisle width for pallets 800 x 1200	AST (mm)	2385
4.25	Minimum aisle width for pallets 1000 x 1200	AST (mm)	2465	
4.26	Handle Operating Arc	S(°)	65	
Performance Data	5.1	Travel speed, laden/unladen	kph	3.5/4
	5.2	Lift speed, laden/unladen	mm/s	130/230
	5.3	Lowering speed, laden/unladen	mm/s	0.190
	5.4	Max.gradeability, laden/unladen	%	8/5
	5.5	Service brake		Electromagnetic braking
Electric-motor	6.1	Drive motor rating S2 60 min.	kW	1.5 AC
	6.2	Lift motor rating at S3 15%	kW	4.5 DC
	6.3	Battery voltage/nominal capacity K5	V/Ah	24/345
	6.4	Minimum battery weight	kg	300
	6.5	Steering Motor	kW	0.15 DC
Others	7.1	Type of drive control		AC CURTIS
	7.2	Steering design		Electronic steering
	7.3	Sound pressure level at the driver's seat	dB(A)	70

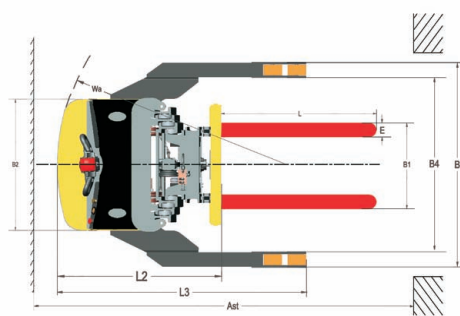
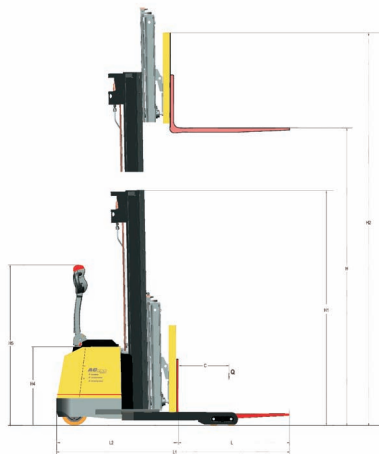

Forklift dimensions

Note: Specifications are affected by the condition of the vehicle and how it is equipped, as well as the nature and condition of the operating area. If these specifications are critical, the proposed application should be discussed with your dealer.

Notice: Care must be exercised when handling elevated load. When the carriage and/or load is elevated, truck stability is reduced. Operators must be trained and adhere to the instructions contained in the Operating Manual.