

Checkweigher Flexus® Combi

Hygienic design meets flexibility and metal detection



German Quality



! Advantages

- Hygienic design for easy cleaning and the highest level of quality in your production operations
- Safety and reliability thanks to EMFC load cell technology
- The ideal solution every time – for your application configure Flexus® Combi
- Easy to combine with metal detection technology Vistus®



The Checkweigher Flexus® Combi combines the benefits of checkweighing and metal detection technology in one space-saving system. Minimal space – maximum quality control.

Checkweighing and metal detection in a single system

- ! With Flexus® Combi, you can check the **weight** and/or **integrity of your product and optimise your filling processes**. At the same time, all **metal foreign bodies, including ferrous and non-ferrous metals and even non-magnetic stainless steels**, are reliably detected.
- ! Its hygienic design ensures **easy inspection and cleaning**.
- ! Flexus® Combi is incredibly easy to integrate into your production environment. Changes to line configurations and quick transitions between products are handled **with minimal effort**.
- ! The high-resolution **EMFC load cell technology** and the **extremely sturdy construction** guarantee precise weighing results and a high throughput of up to 600 pieces per minute.

Flexible – hygienic – high-performance

The Checkweigher Flexus® Combi has been specially developed to comply with guidelines and standards such as IFS and BRC. It is approved for use in legal metrology for FPV (German Prepackages Act) checks, and is MID-compliant in accordance with OIML R51. Thanks to its intelligent, modular construction and hygienic design, the Flexus® Combi can be configured to suit your individual requirements, providing you with the ideal solution for any challenge you face.



As a member of the EHEDG, we develop our products based on a wide range of hygienic design guidelines.

Technical data – Flexus® Combi

The results achievable in practice, e.g. for the standard deviation attributable to measurement error or the throughput, depend on the relevant application.

Weighing system	WS 1 kg	WS 2 kg	WS 5 kg	WS 7 kg
Gross weighing range [g]	Up to 1,000	Up to 2,000	Up to 5,000	Up to 7,000
Smallest permissible calibration value [g]	0.1	0.2	0.5	1
Standard deviation attributable to measurement error (s) [mg]	From 17	From 83	From 250	From 333
Standard throughput [pcs/min]	Depends on product, throughput, ambient conditions and area of application			
	Max. 250	Max. 200	Max. 180	Max. 180
Standard speed ranges [m/s]	Depends on version, product, permissible imprecision, ambient conditions and area of application			
	0.2 to 1.5	0.2 to 1.0 0.5 to 1.5	0.2 to 1.0 0.5 to 1.4	0.2 to 1.0 0.5 to 1.4
	Other speeds on request; verifiable up to 3 m/s			
Centre-to-centre distance of weighing belt [mm]	210/310	300/350/400/450/500		
Belt width [mm]	See 'Versions' table			
Weighing belt roller diameter [mm]	22	30		
Drives	Maintenance-free 24 V EC motors with planetary gear Motor control, short-circuit-proof with temperature monitoring			
Supply voltage	115/230 V _{AC} (+10%/-15%); 50/60 Hz (L1, N, PE) switchable			
Power consumption	Approx. 600 VA			
Operating pressure	Default setting: Pusher: approx. 3 bar Blower: approx. 5 bar			
Feed direction	Right to left or left to right (please indicate when ordering)			
Working height* [mm]	500 to 1,400 with standard adjustable feet 575 to 1,475 with hygienic adjustable feet (Adjustable foot range +/-25) * Working height below 650 mm results in limited floor clearance when combined with the collection container option			
Floor clearance [mm]	200 with adjustable foot range +/-25 (standard) 275 with adjustable foot range +/-25 (hygienic adjustable feet)			
Permissible operating temperature range [°C]	0 to +40 (MID +5 to +40)			
Conveyor system temperature range [°C]	-10 to +100 (WS 1 kg, belt) -30 to +70 (WS 1 kg, round belt) -30 to +80 (WS 2 to 7 kg, belt)			
Protection class	IP 54 (standard), IP 65 (optional)			
Dimensions	See scale drawings			
Weigher frame material	Stainless steel 1.4301			
Weight	300 kg to 500 kg, depending on version			
Airborne noise emitted	A-weighted sound pressure level emitted < 70 dB(A)			
Inputs	8/16 (optional) digital inputs, 24 V inputs galvanically isolated with a relay or with optocoupler, depending on use			
Outputs	8/16 (optional) digital outputs, 24 V outputs galvanically isolated with a relay or with optocoupler, depending on use 2 analogue outputs, 0–20 mA, 0–10 V Voltage output: Load ≥ 2 kΩ Current output: Load ≤ 300 Ω			

Technical specifications – Checkweigher Flexus® Combi

Create your individual Checkweigher Flexus® Combi from a wide range of options and function enhancements. We'd be happy to advise you!

Checkweigher Flexus® Combi – standard	
Dialogue PC	10 Flexus®: 10.4-inch TFT colour display with keypad
Weight display	Choice of gross, net or differential weight
Operational display	Choice of distribution, yield, throughput, average value chart, large weight readout
Operating modes	Classifying weigher with AWC evaluation; freely selectable class limits; 3-way or 5-way classifying/sorting; statistics with logging of all products; load cell with EMFC technology; product data memory for 200 products; choice of languages for program dialogues, user-selected; self-monitoring via error report; auxiliary functions: dialogues for diagnostics and service, data stored in battery-backed memory, batch mode, automatic zero-setting of the load cell, program-controlled belt speed
Digital input	Hide weigher, event counter, external error message
Digital output	Feeder/batch, 3-way/5-way sorting, total counter/pre-selection counter, error message output, time-unit-controlled sorting
Separation system	One separator including: pusher or blower (depending on product size)
Weighing belt	Various lengths and widths
Metal detector functions	Product effect minimisation, check using parts, test part check, metal accumulation, negative metal detection

Checkweigher Flexus® Combi – optional for increased requirements			
Connectivity	Fieldbus	PROFIBUS-DP, PROFINET IO, DeviceNet, Ethernet/IP	
	Data communication		
	Factory bus TCP/IP, Ethernet, Ethernet/IP	XML client, XML server, prepared for SPC@Enterprise and OPC DA server	
	Individual weight value output for external evaluation and connection to customer systems	Serial interface RS 422, RS 232 or current loop	
	All interfaces specified here are free from feedback and do not need to be secured.		
SPC@Remote	Remote control for checkweigher – suitable for many different applications		
Control	Calibration approval	Verifiable in accordance with OIML R 51 - MID	
	Control functions	Integrity checking/with floating mean value, measuring accuracy check by entering package control weight, automatic sampling of packaging for checking upstream filler	
		USB printing	
		Logging system for external printer	
	Volume evaluation	Without air buoyancy correction, with air buoyancy correction	
	Trend controller with display	3-point controller +/- control signal, 3-point controller with pulse packet, integral controller 0–20 mA/0–10 V	
User-defined access control (audit trail) as per FDA 21 CFR Part 11	Specifications according to FDA requirements (Food and Drug Administration) for data stored electronically and electronic signatures		
Control	3-way/5-way classifying display	3-way signal light, 5-way signal light, isolated outputs, isolated outputs with 3-way signal light, isolated outputs with 5-way signal light	
	Separation system	Control of customer sorting/separating equipment	
	Monitoring functions		
	Compressed air monitoring	Isolated output, belt stop	
	Separation monitoring	Isolated output	
	Goods flow	Isolated output with belt stop	
	Package length/interval monitoring	Using additional light barrier	
	Fill level monitoring	Isolated output with light	
	Collection container	Isolated output with light	
	Incorrect weight	Monitoring of average value and repetitive rejections	
Production monitoring	Monitoring of average value and repetitive rejections		
Sorting with path cycle/ displacement sensor			
Mechanical designs	Dialogue PC	15 Flexus®: TFT colour 15.0 inch, touchscreen	
	Emergency stop button	Built into PC panel	
	Incorrect weight collection container	Made from plastic (for products up to 500 g and a maximum belt width of 200 mm) or stainless steel	
	Separation systems	Rocker, swivel arm, multi-segment separator	
	Transfer runways	Only for WS 1 kg/2 kg – up to a belt width of 200 mm	
	Options	Wind protector, covers, LEDs, horn, IP65, guide rail, side-grip belts, stand-alone load cell and weighing belt, separate installation of weighing system and electronics with display and remote terminal, multiline systems, hygienic adjustable feet, additional infeed belt or outfeed belt, pneumatics in stainless steel housing	
Metal detection options	Synchronization light barrier Vistus®		
	Metal detector functions	Product flow monitoring, metal notification with separate acknowledgement, path cycle metal detector, collection container with password protection (digital lock), FDA 21 CFR Part 11 audit trail, external inspection request, collection container fill level monitoring	

Scale drawings

Front view

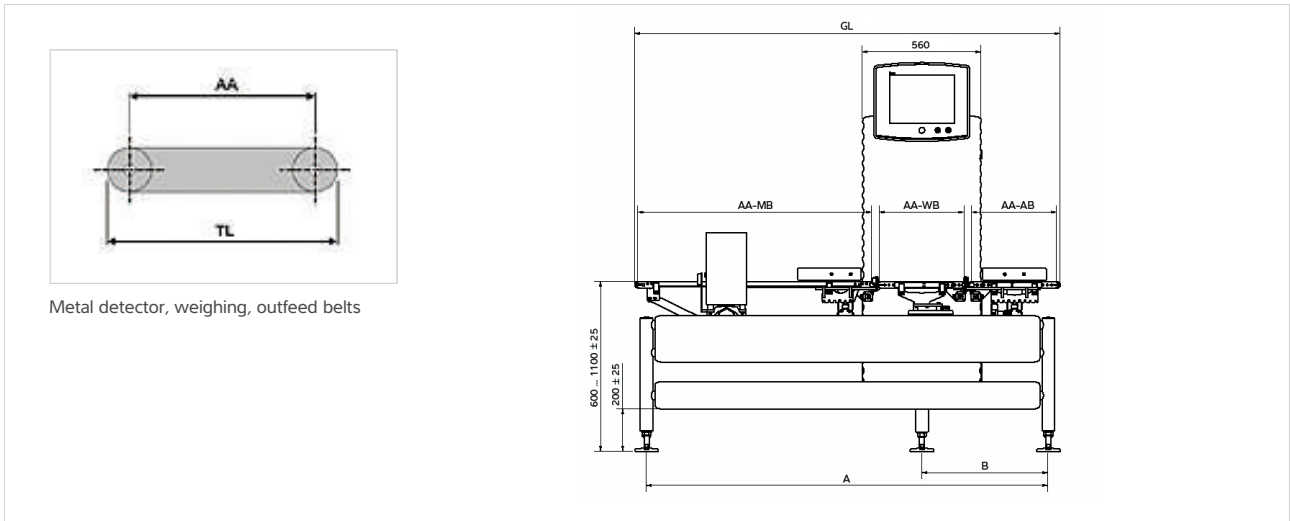

Metal detector, weighing, outfeed belts

The figure shows a combi system with transport direction from left to right as an example.

AA-MB	Centre-to-centre distance of metal detector belt [mm]
AA-WB	Centre-to-centre distance of weighing belt [mm]
AA-AB	Centre-to-centre distance of outfeed belt [mm]
C	Metal detector coil passage height [mm]
A	Variable; see scale drawing [mm]
B	Variable; see scale drawing [mm]
GL	Total length [mm]
u	Metal detector coil installed upright
TL	Platform length [mm] TL = AA + roller diameter (30 mm, or 22 mm in the case of the 1 kg weighing belt)

For belt widths BB = 150/200/250/300, additional lengths are available for outfeed belts with centre-to-centre distance AA = 550/600/650/700.

Dimensions table: WS 1 kg

AA-MB	AA-WB	AA-AB	C	A	B	GL
900	210	350	90, 125, 150	1,440	445	1,550
		400		1,490	495	1,600
		450		1,540	545	1,650
		500		1,590	595	1,700
1,000	210	350	90, 125, 150	1,540	445	1,650
		400		1,590	495	1,700
		450		1,640	545	1,750
		500		1,690	595	1,800
1,100	210	350	90, 125, 150, 200, 275u, 375u	1,640	445	1,750
		400		1,690	495	1,800
		450		1,740	545	1,850
		500		1,790	595	1,900
800	310	300	90, 125, 150	1,390	445	1,500
		350		1,440	495	1,550
		400		1,490	545	1,600
		450		1,540	595	1,650
		500		1,590	645	1,700
900	310	300	90, 125, 150	1,490	445	1,600
		350		1,540	495	1,650
		400		1,590	545	1,700
		450		1,640	595	1,750
		500		1,690	645	1,800
1,000	310	300	90, 125, 150, 200, 275u, 375u	1,590	445	1,700
		350		1,640	495	1,750
		400		1,690	545	1,800
		450		1,740	595	1,850
		500		1,790	645	1,900
1,100	310	300	90, 125, 150, 200, 275u, 375u	1,690	445	1,800
		350		1,740	495	1,850
		400		1,790	545	1,900
		450		1,840	595	1,950
		500		1,890	645	2,000

Dimensions table: WS 2/5/7 kg

AA-MB	AA-WB	AA-AB	C	A	B	GL
800	300	300	90, 125, 150	1,390	445	1,500
		350		1,440	495	1,550
		400		1,490	545	1,600
		450		1,540	595	1,650
		500		1,590	645	1,700
900	300	300	90, 125, 150	1,490	445	1,600
		350		1,540	495	1,650
		400		1,590	545	1,700
		450		1,640	595	1,750
		500		1,690	645	1,800
1,000	300	300	90, 125, 150, 200, 275u, 375u	1,590	445	1,700
		350		1,640	495	1,750
		400		1,690	545	1,800
		450		1,740	595	1,850
		500		1,790	645	1,900
1,100	300	300	90, 125, 150, 200, 275u, 375u	1,690	445	1,800
		350		1,740	495	1,850
		400		1,790	545	1,900
		450		1,840	595	1,950
		500		1,890	645	2,000
800	350	350	90, 125, 150	1,490	520	1,600
		400		1,540	570	1,650
		450		1,590	620	1,700
		500		1,640	670	1,750
		550		1,690	720	1,800
900	350	350	90, 125, 150	1,590	520	1,700
		400		1,640	570	1,750
		450		1,690	620	1,800
		500		1,740	670	1,850
		550		1,790	720	1,900
1,000	350	350	90, 125, 150, 200, 275u, 375u	1,690	520	1,800
		400		1,740	570	1,850
		450		1,790	620	1,900
		500		1,840	670	1,950
		550		1,890	720	2,000
1,100	350	350	90, 125, 150, 200, 275u, 375u	1,790	520	1,900
		400		1,840	570	1,950
		450		1,890	620	2,000
		500		1,940	670	2,050
		550		1,990	720	2,100
900	400	400	90, 125, 150	1,690	595	1,800
		450		1,740	645	1,850
		500		1,790	695	1,900
1,000	400	400	90, 125, 150	1,790	595	1,900
		450		1,840	645	1,950
		500		1,890	695	2,000
1,100	400	400	90, 125, 150, 200, 275u, 375u	1,890	595	2,000
		450		1,940	645	2,050
		500		1,990	695	2,100
900	450	450	90, 125, 150	1,790	670	1,900
		500		1,840	720	1,950
1,000	450	450	90, 125, 150	1,890	670	2,000
		500		1,940	720	2,050
1,100	450	450	90, 125, 150, 200, 275u, 375u	1,990	670	2,100
		500		2,040	720	2,150
900	500	500	90, 125, 150	1,890	745	2,000
1,000	500	500	90, 125, 150	1,990	745	2,100
1,100	500	500	90, 125, 150, 200, 275u, 375u	2,090	745	2,200

Side view

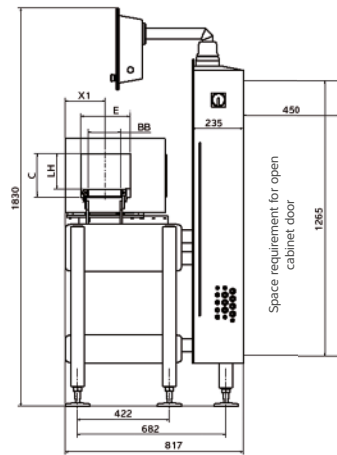

BB-MB	Metal detector belt width [mm]
BB-WB	Weighing belt width [mm]
E	Metal detector coil passage width [mm]
C	Metal detector coil passage height [mm]
LH	Clear height [mm]
X1	Variable; see scale drawing [mm]
u	Metal detector coil installed upright

Dimensions table: WS 1 kg

BB-MB	BB-WB	E	C	LH	X1
150	50	225	90	50	183
			125	85	
			150	110	
			200	160	
		200	275u	235	
			375u	335	
150	100	225	90	50	183
			125	85	
			150	110	
			200	160	
		200	275u	235	
			375u	335	
150	150	225	90	50	183
			125	85	
			150	110	
			200	160	
		200	275u	235	
			375u	335	
200	200	275	90	50	208
			125	85	
			150	110	
			200	160	

Dimensions table: WS 2/5/7 kg

BB-MB	BB-WB	E	C	LH	X1
150	150	225	90	50	183
			125	85	
			150	110	
		200	200	160	
			275u	235	
			375u	335	
200	200	275	90	50	208
			125	85	
			150	110	
			200	160	
250	250	325	90	50	233
			125	85	
			150	110	
			200	160	
300	300	375	90	50	258
			125	85	
			150	110	
			200	160	

Versions

AA	Centre-to-centre distance [mm]
BB	Belt width [mm]
C	Metal detector coil passage height [mm]
u	Metal detector coil installed upright
●	Round belt or belt version
■	Belt version

WS 1 kg

BB x AA [mm]			C
Metal detector belt ■	Weighing belt ●	Outfeed belt ■	
150 x 800	50 x 310	150 x 300/350/400/450/500	90/125/150
	100 x 310		
	150 x 310		
150 x 900	50 x 210	150 x 350/400/450/500	90/125/150
	100 x 210		
	150 x 210		
150 x 900	50 x 310	150 x 300/350/400/450/500	90/125/150
	100 x 310		
	150 x 310		
150 x 1,000	50 x 210	150 x 350/400/450/500	90/125/150
	100 x 210		
	150 x 210		
150 x 1,000	50 x 310	150 x 300/350/400/450/500	90/125/150/200/275u/375u
	100 x 310		
	150 x 310		
150 x 1,100	50 x 210	150 x 350/400/450/500	90/125/150/200/275u/375u
	100 x 210		
	150 x 210		
150 x 1,100	50 x 310	150 x 300/350/400/450/500	90/125/150/200/275u/375u
	100 x 310		
	150 x 310		
200 x 800	200 x 310	200 x 300/350/400/450/500	90/125/150
200 x 900	200 x 210	200 x 350/400/450/500	90/125/150
200 x 900	200 x 310	200 x 300/350/400/450/500	90/125/150

BB x AA [mm]			C
Metal detector belt ■	Weighing belt ●	Outfeed belt ■	
200 x 1,000	200 x 210	200 x 350/400/450/500	90/125/150
200 x 1,000	200 x 310	200 x 300/350/400/450/500	90/125/150/200/275u/375u
200 x 1,100	200 x 210	200 x 350/400/450/500	90/125/150/200/275u/375u
200 x 1,100	200 x 310	200 x 300/350/400/450/500	90/125/150/200/275u/375u

WS 2/5/7 kg

AA [mm]				C
BB [mm]	Metal detector belt ■	Weighing belt ■	Outfeed belt ■	
150	800	300	300/350/400/450/500	90/125/150
		350	350/400/450	
	900	300	300/350/400/450/500	90/125/150
		350	350/400/450/500	
		400	400/450/500	
		450	450/500	
		500	500	
	1,000	300	300/350/400/450/500	90/125/150/200/275u/375u
		350	350/400/450/500	
		400	400/450/500	90/125/150
		450	450/500	
		500	500	
	1,100	300	300/350/400/450/500	90/125/150/200/275u/375u
		350	350/400/450/500	
		400	400/450/500	
		450	450/500	
500		500		
200	800	300	300/350/400/450/500	90/125/150
		350	350/400/450/500	
	900	300	300/350/400/450/500	90/125/150
		350	350/400/450/500	
		400	400/450/500	
		450	450/500	
		500	500	
	1,000	300	300/350/400/450/500	90/125/150/200
		350	350/400/450/500	
		400	400/450/500	90/125/150
		450	450/500	
		500	500	
	1,100	300	300/350/400/450/500	90/125/150/200
		350	350/400/450/500	
		400	400/450/500	
		450	450/500	
500		500		
250	800	300	300/350/400/450/500	90/125/150
		350	350/400/450/500	
	900	300	300/350/400/450/500	90/125/150
		350	350/400/450/500	
		400	400/450/500	
		450	450/500	
		500	500	
	1,000	300	300/350/400/450/500	90/125/150/200
		350	350/400/450/500	
		400	400/450/500	90/125/150
		450	450/500	
		500	500	
	1,100	300	300/350/400/450/500	90/125/150/200
		350	350/400/450/500	
		400	400/450/500	
		450	450/500	
500		500		

WS 2/5/7 kg

AA [mm]				C	
BB [mm]	Metal detector belt ■	Weighing belt ■	Outfeed belt ■		
300	800	350	350/400/450/500	90/125/150	
		350	350/400/450/500		
	900	400	400/450/500		
		450	450/500		
		500	500		
		350	350/400/450/500		90/125/150/200
	1,000	400	400/450/500	90/125/150	
		450	450/500		
		500	500		
		1,100	350	350/400/450/500	90/125/150/200
			400	400/450/500	
			450	450/500	
500	500				

Versions

The scale drawing shows Flexus® Combi with a collection container (optional), which is made from plastic or stainless steel – both versions have different dimensions.

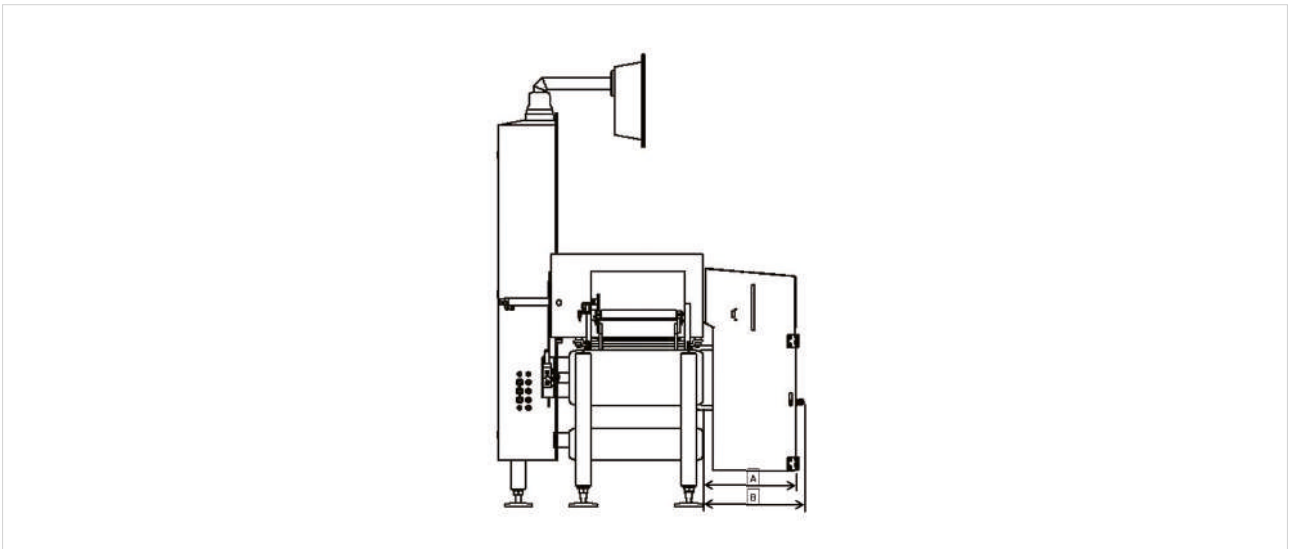

A	Minimum depth of the collection container
B	Maximum depth (incl. key) of the collection container

Material	A [mm]	B [mm]
Plastic	272	303
Stainless steel	372	403

Product description

Machine construction

The Flexus® Combi comprises the Checkweigher Flexus® combined with integrated Metal detector Vistus®-S. It is operated using a joint terminal. The system is therefore used not only to detect products contaminated with metal, but also to transport and weigh goods to be conveyed.

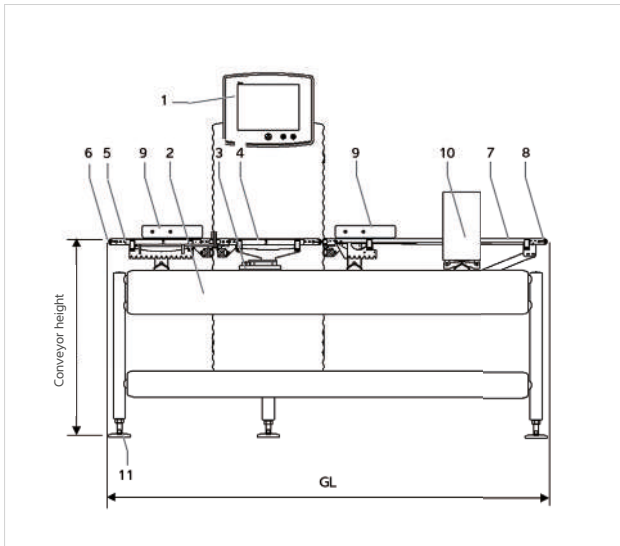

- 1 Display and remote terminal
- 2 Weigher frame
- 3 Load cell
- 4 Weighing belt
- 5 Outfeed belt
- 6 Connection to customer outfeed belt
- 7 Metal detector belt
- 8 Connection to customer infeed belt
- 9 Separator
- 10 Metal detector
- 11 Spindle adjustable feet

A three-part conveyor belt system transports the products from right to left. All conveyor belts (4, 5, 7) in the system run at the same speed to ensure that products are transferred smoothly onto and off of the weighing belt. The weighing process is carried out dynamically and automatically without intervention by operating personnel. The weight value, including mass unit, is converted and shown on the display.

Weigher frame with control cabinet

Crossbars are fitted to the weigher frame (2). The weighing and transport system is attached to these crossbars. The pillar cabinet with its sinusoidal housing profile is attached to the weigher frame using a clamping device. The working height of the weigher frame is determined by the length of the frame legs. The working height can be adjusted by changing or modifying the frame legs. Small adjustments to the working height can be made via the spindle adjustable feet (11). The display and remote terminal (1) is installed in front of the control cabinet.

Load cell

The load cell (3) is a monolithic, electro-magnetic force compensation load cell (EMFC). This delivers maximum precision, extremely short settling times, high long-term stability and overload protection in a stainless steel housing.

Transport system

A conveyor belt is used as the transport medium (weighing belt WS 1 kg also available with round belt). The belt frame is equipped with a belt quick-clamping device and a hinged, removable transport system. This allows the conveyor belts to be removed/fitted and replaced without tools. A 'non-antistatic' belt must be used as the metal detector belt. 'Non-antistatic' belts have no influence on the magnetic field of the detector coil and are therefore optimally suited for use in conjunction with metal detectors. It must be ensured that the 'non-antistatic' belt does not become electrically charged resulting in electrostatic discharge. If an 'antistatic' belt needs to be used for technical procedural reasons, then it must be anticipated that there will be interference with the sensitivity due to the disruptive signal caused by the belt connection points. The conveyor belt must not have any metallic inclusions. Metallic inclusions may occur if there is welding or grinding on the belt structure and welding or grinding beads fall on the belt and anneal there. The metal detector, weighing and outfeed belts are each driven by an EC geared motor. Power is transmitted via toothed belt.

- The metal detection (7) conveyor takes the products from the upstream machine or from the upstream optional additional infeed belt and passes them through the metal search coil.
- The weighing belt (4) takes the products from the metal detection conveyor. While the products are on the weighing belt, they are weighed while in motion. The weighing belt can optionally be set up separately from the weigher frame.
- The outfeed belt (5) takes the products and transports them further to the downstream optional additional outfeed belt or to the downstream customer belt.

Control electronics

The display and remote terminal for the weighing function is based on an industrial PC with a powerful 32-bit multitasking operating system with data storage on an internal wear-free compact flash memory card. The housing is made from polished stainless steel. The control cabinet is opened using a continuous cabinet door opening to the rear with fasteners. The connection terminals for the power supply, the components of the evaluation and display electronics and the power supply unit with motor control are housed in the control cabinet. The main switch is installed in the control cabinet. The start/stop button for the transport system is located on the front of the display and remote terminal (1), which can be swivelled for ergonomic operation.

Separator (9)

Two compressed air nozzles (standard WS 1 kg) or two pneumatic pushers (standard WS 2–7 kg) are fitted on the crossbars of the weigher frame in the metal detector belt area and in the outfeed belt area to ensure the reliable rejection of products that have a different weight or are contaminated with metal. A filter pressure control valve is included.

Metal detector

Metal detectors (10) protect consumers against damage to health caused by metal parts, prevent the end product from being contaminated by metal and protect processing machines against damage. As well as magnetic metal parts, metal detectors also detect high-alloy steels and non-ferrous metals (copper, brass, aluminium, lead etc.).

Rubber-bonded metal elements

To prevent the metal detector from being influenced by vibrations of the belt structure and to insulate the metal detector electrically against the belt structure, the metal detector must be equipped with four rubber-bonded metal elements at the factory.

The metal detector is secured to the belt structure or to a separate bracket using the rubber-bonded metal elements.

Light barrier

The light barrier is required when separating oddly shaped products using a pusher or blower in order to precisely control the separator. The light barrier is used to synchronise the metal signal with the product.

Displacement sensor

In the case of conveyor belts that have a variable belt speed and therefore a changeable displacement/rejection time, a displacement sensor is required that will generate pulses proportional to the distance. The distance pulse is generated by the drive motor.

Detector coil

The rectangular detector channel, which is available in various sizes, is incorporated in the stainless steel housing (material 1.4301), which is welded on all sides. Selection guidelines for the detector coil (see dimensions table)

- Passage width: The passage width of the detector coil (dimension 'E' in the dimensions table) is determined based on the width of the conveyor belt (dimension 'BB').
- Passage height: The detection sensitivity is dependent above all on the passage height, so it is important to select the lowest height required. The passage height (dimension 'C' in the dimensions table) is determined based on the maximum product height processed plus 40 mm.
- Type designation: The type designation includes the passage width (dimension 'E' in the dimensions table) and passage height (dimension 'C' in the dimensions table) in cm. Example: 22.5 x 9 Vistus®-S: passage width = 225 mm, passage height = 90 mm (clear height = 50 mm, dimension 'LH' in the dimensions table).