



# CONTINUOUS RUN VENT UNLOADERS

## Mark III Load Genie®

The LGM 30 - Mark III Load Genie continues the tradition of the original Mark II. Over 25 years of experience were incorporated into the design and development of this continuous run control.

The Mark III combines all components required for a continuous run compressor application: the pilot valve, the vent valve, and the check valve. Since the Mark III is a "vent" unloader, built-in compressor head unloaders are not required.

The compact size and straight-through flow design of the Mark III make installation easy. Simply install the Mark III into the air receiver and attach the compressor discharge line to the valve inlet. The Mark III is suitable for compressors of up to 30 SCFM delivery.

Cut-in and cut-out pressure settings are factory set to customer specifications. Minimum cut-out pressure is 250 PSI (1725 kPa). The valve is also field adjustable.

Details of construction include a forged brass body, zinc-plated steel internal components, fluorocarbon piston ring, stainless steel springs, and a glass-filled fluopolymer check valve poppet.



Options include a 1/8" NPT tapped port for throttle control of a gas engine, a lockout clip for "dual control" applications, a special 1/8" NPT tapped port for pressure switch unloader valve, a vent port muffler, and a toggle unloading lever for one-hand warm up control.

Model	Inlet	Outlet Male	Vent Outlet Female	Max Flow Rate	Cut-In (psi)	Cut-Out (psi)	Weight (kgs)	Part Number
LGM30	1/2" NPT F	1/2" NPT	3/8" NPT	30 SCFM	109	138	0.5	4002330
LGM30	1/2" Comp	1/2" NPT	3/8" NPT	30 SCFM	95	115	0.5	4002331
LGM30	Flare #8JIC	1/2" NPT	3/8" NPT	30 SCFM	95	125	0.5	4002332
KTM300	LGM30 Repair Kit							4002335

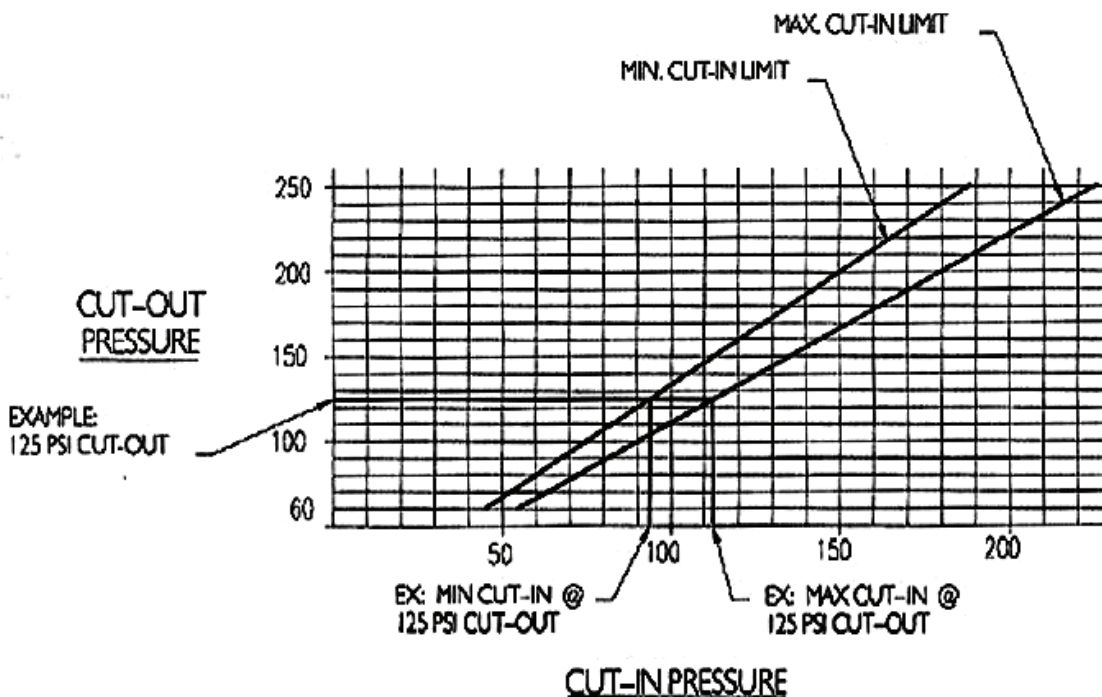

The data provided above is for information purposes only and no warranty of accuracy or reliability is given. Ross Brown Sales Pty Limited reserves the right to change or modify this data without prior notice.



### Mark III Load Genie®

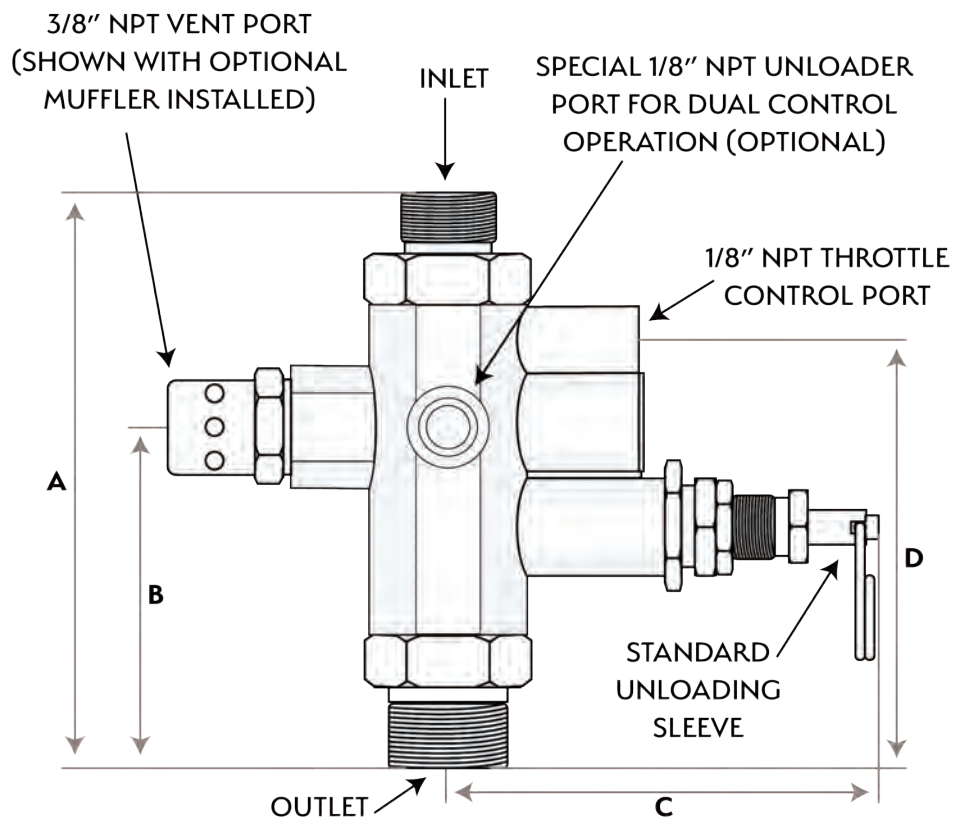
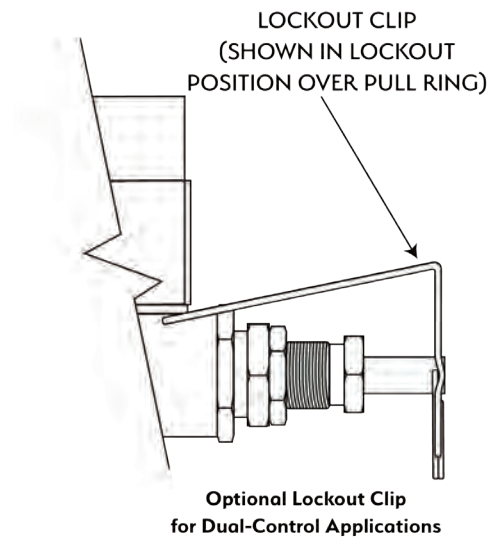
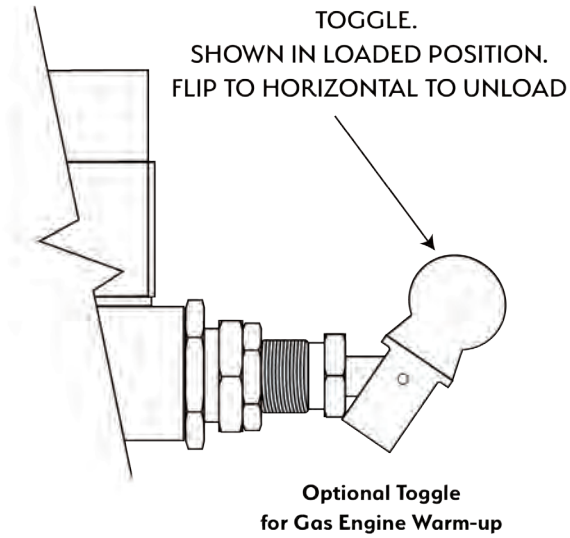

Dimensions (mm)			
A	B	C	D
83.3	41.9	53.3	56.1

The data provided above is for information purposes only and no warranty of accuracy or reliability is given.  
Ross Brown Sales Pty Limited reserves the right to change or modify this data without prior notice.