



ON-PREMISE LAUNDRY



T-50 DRYER

Dexter On-Premise Dryer

On-premise laundry solutions you can depend on.

Dexter on-premise dryers are engineered to show up for work in even the harshest laundry environments. Featuring flexible controls and high quality materials, these fast and efficient dryers are designed to help you process laundry faster and more efficiently.

When your business depends on clean laundry, choosing the right equipment is an important decision. Our products will provide you the efficiency, flexibility, performance, and durability you need to be confident in your choice. With lifetime technical support and an industry leading 5 year limited warranty, you can be confident that we will stand behind every dryer you invest in.

Contact your Dexter Authorized Distributor today for more details.

EFFICIENT:

Perforated tumblers, balanced radial airflow, and the right amount of air recirculation provide maximum efficiency.

The anti-wrinkle feature offers an intermittent tumble to keep laundry wrinkle free.

DURABLE:

With heavy-duty bearings in a cast iron bearing housing and a fully welded and painted cabinet, Dexter dryers are built to last.

Using proven washer-style technology, welded steel spider assemblies support the tumbler from the rear and eliminate the need for front support rollers.

Formed in tumbler baffles are strong and stable while providing great tumbling action.

RELIABLE:

Our industry leading 5 year warranty covers the trunnion, bearings, and bearing housing.

A 3 year parts warranty covers the rest.

We stand behind every machine you invest in with lifetime technical support.

FLEXIBLE:

The reversible door option on all on-premise single dryers allows for a more ergonomic set up when needed.

Dexter on-premise dryer controls offer adjustable settings and five customizable cycles that provide the power and flexibility needed to fit any laundry.

INSTALLATION:

Vertical exhaust and venting come standard on every dryer for easy installation.

The exhaust cleanouts are easy to reach and allow for regular maintenance.

The hinged lower service door makes cleaning the lint screen quick and easy.

OPTIONS:

Available with stainless steel or galvanized tumblers and white or stainless steel panels.

Choose between gas models or electric models. Propane kits are available.

Dexter single dryers are available in 30lb, 50lb, 80lb, and 120lb capacities.

EMPLOYEE OWNED | MADE IN THE USA | SINCE 1894

GCLE.COM.AU

PO BOX 3920 ROBINA TC, QLD 4230 AUSTRALIA

1300 309 708

T-50 EXPRESS DRYER SPECIFICATIONS

ON-PREMISE LAUNDRY

Capacity:

Dry Weight Capacity	50 lb	(22.7 kg)
Cylinder Volume	15.8 cu ft	(447.4 L)

Speed:

Tumbler Speed	45 RPM	
Motor Size - 60 Hz Model	1 hp	(0.75 kW)
Motor Size - 50 Hz Model	0.75 hp	(0.56 kW)

Airflow:

60 Hz Model	910 cfm	(25.8 M3/min)
50 Hz Model	760 cfm	(21.5 M3/min)

Dimensions:

Cabinet Height	72 1/4"	(183.5 cm)
Cabinet Width	34 1/2"	(87.6 cm)
Overall Depth	50"	(127 cm)
Door Opening	25 5/8"	(65.1 cm)
Floor to Door Bottom	27 1/4"	(69.2 cm)
Cylinder Diameter	36 1/2"	(92.7 cm)
Cylinder Depth	33"	(83.8 cm)
Lint Screen Area	708 sq in	(4568 sq cm)

Weight:

Net Weight	579 lbs	(262.6 kg)
------------	---------	------------

Shipping Information:

Shipping Weight	611 lbs	(277.1 kg)
Shipping Height	77 1/4"	(196.2 cm)
Shipping Width	36"	(91.4 cm)
Shipping Depth	54 1/2"	(138.4 cm)

Gas Requirements (Gas Models Only):

Gas Supply Connection	1/2"	(12.7 mm)
Natural Gas Supply (Water Column)	5-10"	(12.7 - 25.4 cm)
LP Gas Supply (Water Column)	11 1/2 - 13 1/2"	(29.2 - 34.3 cm)

Gas Usage (Gas Models Only):

60Hz Model	145,000 BTU/hr	(42.5 kW)
50Hz Model	120,000 BTU/hr	(35.2 kW)

Electrical Requirements:

Gas Models:

Model	Volts / Hz / Phase / Wiring	Circuit Breaker / Running Amps / Wire Size
-10	120 / 60 / 1 / 2 wire + ground	15 amp / 9.6 amp / #12
-39	230 / 50 / 1 / 2 wire + ground	10 amp / 5.1 amp / 2.1 mm ²

Electric Models:

Model	kW / Volts / Hz / Phase / Wiring	Circuit Breaker / Running Amps / Wire Size
-16FC	24 / 208 / 60 / 3 / 4 wire + ground	90 amp / 85 amp / #2
-16FE	30 / 208 / 60 / 3 / 4 wire + ground	100 amp / 100 amp / #1
-18FD	24 / 240 / 60 / 3 / 4 wire + ground	80 amp / 75 amp / #3
-18FG	30 / 240 / 60 / 3 / 4 wire + ground	90 amp / 90 amp / #2
-64FN	24 / 400 / 50 / 3 / 4 wire + ground	50 amp / 45 amp / 13.3 mm ²

Installation Recommendations:

Minimum Clearance Between Machines	0"	(0 cm)
Minimum Clearance Behind Machines	18"	(45.7 cm)
Make-Up Air Required	1.25 sq ft	(1161 sq cm)
Exhaust Size	8"	(20.3 cm)

Agency Approvals*

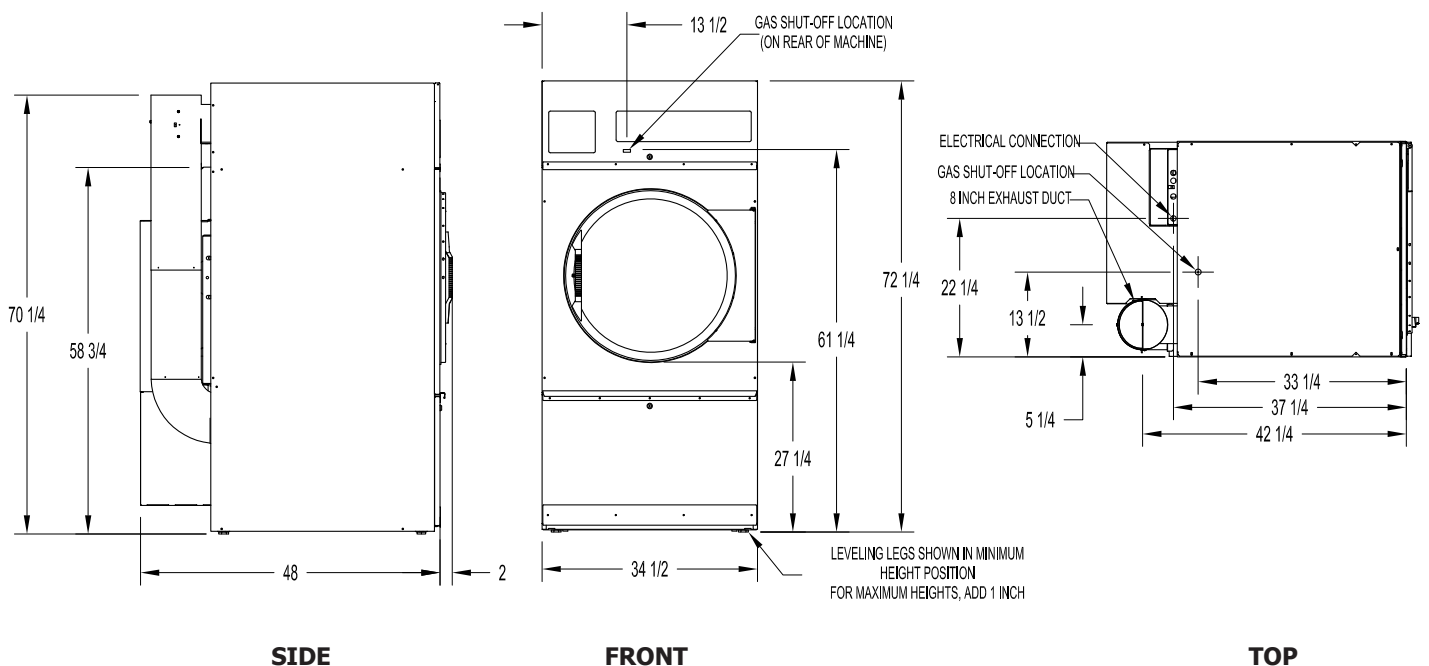

Due to continuous product improvements specifications are subject to change, please consult the installation manual for the most accurate information.
 *Agency approvals may vary depending on the machine configuration, consult Dexter Laundry or your Dexter Authorized Distributor for details.