

SkyLine PremiumS Electric Combi Oven 6GN2/1, Green Version

ITEM # _____

MODEL # _____

NAME # _____

SIS # _____

AIA # _____

229731 (ECO62T3S0)

SkyLine PremiumS combi boiler oven with touch screen control, 6x2/1GN, electric, 3 cooking modes (automatic, recipe program, manual), automatic cleaning, Green Version with 3-glass door

Short Form Specification

Item No.

- Combi oven with high resolution full touch screen interface, multilanguage
- Built-in steam generator with real humidity control based upon Lambda Sensor
 - OptiFlow air distribution system to achieve maximum performance with 7 fan speed levels
 - SkyClean: Automatic and built-in self cleaning system with integrated descale of the steam generator. 5 automatic cycles (soft, medium, strong, extra strong, rinse-only) and green functions to save energy, water, detergent and rinse aid
 - Cooking modes: Automatic (9 food families with 100+ different pre-installed variants); Programs (a maximum of 1000 recipes can be stored and organized in 16 different categories); Manual (steam, combi and convection cycles); Specialistic Cycles (regeneration, Low Temperature Cooking, proving, EcoDelta, Sous-Vide, Static-Combi, Pasteurization of pasta, dehydration, Food Safe Control and Advanced Food Safe Control)
 - Special functions: MultiTimer cooking, Plan-n-Save to cut running costs, Make-it-Mine to customize interface, SkyHub to customize homepage, agenda MyPlanner, SkyDuo connection to SkyLine ChillerS, automatic backup mode to avoid downtime
 - USB port to download HACCP data, programs and settings. Connectivity ready
 - 6-point multi sensor core temperature probe
 - Triple-glass door with double LED lights line
 - Stainless steel construction throughout
 - Supplied with n.1 tray rack 2/1 GN, 67 mm pitch.

Main Features

- High resolution full touch screen interface (translated in more than 30 languages) - color-blind friendly panel.
- Built-in steam generator for highly precise humidity and temperature control according to the chosen settings.
- Real humidity control based upon Lambda Sensor to automatically recognize quantity and size of food for consistent quality results.
- Dry, hot convection cycle (25 °C - 300 °C): ideal for low humidity cooking.
- Combination cycle (25 °C - 300 °C): combining convected heat and steam to obtain humidity controlled cooking environment, accelerating the cooking process and reducing weight loss.
- Low temperature Steam cycle (25 °C - 99 °C): ideal for sous-vide, re-thermalization and delicate cooking. Steam cycle (100 °C): seafood and vegetables. High temperature steam (25 °C - 130 °C).
- Automatic mode including 9 food families (meat, poultry, fish, vegetables, pasta/rice, eggs, savory and sweet bakery, bread, dessert) with 100+ different pre-installed variants. Through Automatic Sensing Phase the oven optimizes the cooking process according to size, quantity and type of food loaded to achieve the selected cooking result. Real time overview of the cooking parameters. Possibility to personalize and save up to 70 variants per family.
- Cycles+: - Regeneration (ideal for banqueting on plate or rethermalizing on tray), - Low Temperature Cooking (to minimize weight loss and maximize food quality) Patented US7750272B2 and related family, - Proving cycle, - EcoDelta cooking, cooking with food probe maintaining preset temperature difference between the core of the food and the cooking chamber, - Sous-vide cooking, - Static Combi (to reproduce traditional cooking from static oven), - Pasteurization of pasta, - Dehydration cycles (ideal for drying fruits, vegetables, meats, seafood), - Food Safe Control (to automatically monitor safety of cooking process in compliance with HACCP hygienic standards) Patented US6818865B2 and related family, - Advanced Food Safe Control (to drive the cooking with pasteurization factor).
- Programs mode: a maximum of 1000 recipes can be stored in the oven's memory, to recreate the exact same recipe at any time. The recipes can be group in 16 different categories to better organize the menu. 16-step cooking programs also available.
- MultiTimer function to manage up to 20 different cooking cycles at the same time, improving flexibility and ensuring excellent cooking results. Can be saved up to 200 MultiTimer programs.
- OptiFlow air distribution system to achieve maximum performance in cooking evenness and temperature control thanks to a special design of the cooking chamber combined with high precision variable speed fan and venting valve.
- Fan with 7 speed levels from 300 to 1500 RPM and

APPROVAL: _____

reverse rotation for optimal evenness. Fan stops in less than 5 seconds when door is opened.

- 6-point multi sensor core temperature probe for maximum precision and food safety.
- Pictures upload for full customization of cooking cycles.
- Automatic fast cool down and pre-heat function.
- Reduced power function for customized slow cooking cycles.
- SkyClean: Automatic and built-in self cleaning system with integrated descale of the steam generator. 5 automatic cycles (soft, medium, strong, extra strong, rinse-only) and green functions to save energy, water, detergent and rinse aid. Also programmable with delayed start.
- 3 different chemical options available: solid (phosphate-free), liquid (requires optional accessory), enzymatic.
- Plan-n-Save function organizes the cooking sequence of the chosen cycles optimizing the work in the kitchen from a time and energy efficiency point of view.
- Make-it-mine feature to allow full personalization or locking of the user interface.
- SkyHub lets the user group the favorite functions in the homepage for immediate access.
- MyPlanner works as an agenda where the user can plan the daily work and receive personalized alerts for each task.
- With SkyDuo the Oven and the Blast Chiller are connected to each other and communicate in order to guide the user through the cook&chill process optimizing time and efficiency (SkyDuo Kit available as optional accessory).
- GreaseOut: predisposed for integrated grease drain and collection for safer operation (dedicated base as optional accessory).
- USB port to download HACCP data, share cooking programs and configurations. USB port also allows to plug-in sous-vide probe (optional accessory).
- Connectivity ready for real time access to connected appliances from remote and HACCP monitoring (requires optional accessory).
- Trainings and guidances supporting materials easily accessible by scanning QR-Code with any mobile device.
- Back-up mode with self-diagnosis is automatically activated if a failure occurs to avoid downtime.
- Automatic consumption visualization at the end of the cycle.
- [NOT TRANSLATED]
- [NOT TRANSLATED]

Construction

- Human centered design with 4-star certification for ergonomics and usability.
- Wing-shaped handle with ergonomic design and hands-free opening with the elbow, making managing trays simpler (Registered Design at EPO).
- Triple thermo-glazed door with 2 hinged inside panels for easy cleaning and double LED lights line.
- Seamless hygienic internal chamber with all rounded corners for easy cleaning.
- 304 AISI stainless steel construction throughout.
- Front access to control board for easy service.
- Integrated spray gun with automatic retracting system for fast rinsing.
- IPX 5 spray water protection certification for easy

cleaning.

- Supplied with n.1 tray rack 2/1 GN, 67 mm pitch.

Optional Accessories

- Water softener with cartridge STEAM 1200 PNC 920003
- Automatic water softener for ovens PNC 921305
- Resin sanitizer for water softener PNC 921306
- Castor kit for base for 6&10x1/1 and 2/1 GN ovens PNC 922003
- Pair of 1/1 GN AISI 304 grids PNC 922017
- Couple of grids for whole chicken 1/1GN (8 per grid) PNC 922036
- ONE 1/1GN AISI 304 GRID FOR AOS OVEN USA PNC 922062
- ONE 2/1GN AISI 304 GRID FOR AOS OVEN USA PNC 922076
- Side external spray unit (needs to be mounted outside and includes support for mounting to oven) PNC 922171
- Pair of 2/1GN aisi 304 stainless steel grids PNC 922175
- Baking tray with 5 rows (baguette), perforated aluminium with silicon coating (400x600x38) PNC 922189
- Baking tray with 4 edges, perforated aluminium (400x600x20) PNC 922190
- Baking tray with 4 edges, aluminium (400x600x20) PNC 922191
- 2 frying baskets for ovens PNC 922239
- Pastry grid, 400x600mm, AISI 304 stainless steel PNC 922264
- Double-click closing catch for door PNC 922265
- Grid for whole chicken 1/1GN (8 per grid - 1,2kg each) PNC 922266
- USB probe for Sous-Vide cooking - available on Touchline ovens with software versions after 4.10 PNC 922281
- Kit universal skewer rack and 6 short skewers for Lengthwise and Crosswise ovens PNC 922325
- Universal skewer rack PNC 922326
- 6 short skewers PNC 922328
- Smoker for lengthwise and crosswise ovens - 4 kinds of smoker wood chips are available on request PNC 922338
- Multipurpose hook PNC 922348
- 4 FLANGED FEET FOR 6&10 GN - 2 " 100-130MM PNC 922351
- GREASE COLLECTION TRAY WITH DRAIN LOCK - GN 2/1 H=60MM PNC 922357
- GRID FOR 8 WHOLE DUCKS (1.8KG) - GN 1/1 PNC 922362
- TRAY SUPPORT FOR 6&10 GN 2/1 DISASSEMBLED OVEN BASE PNC 922384
- HOLDER FOR DETERGENT TANK - WALL MOUNTED PNC 922386
- SLIDE-IN RACK WITH HANDLE FOR 6&10 GN 2/1 OVEN PNC 922605
- TRAY RACK WITH WHEELS 5 GN 2/1 - 80MM PITCH PNC 922611
- OPEN BASE WITH TRAY SUPPORT FOR 6&10 GN 2/1 OVEN PNC 922613
- CUPBOARD BASE WITH TRAY SUPPORT FOR 6&10 GN 2/1 OVEN PNC 922616

- | | |
|---|---|
| <ul style="list-style-type: none"> • HOT CUPBOARD BASE WITH TRAY SUPPORT FOR 6&10 GN 2/1 OVEN & 400X600MM PNC 922617 <input type="checkbox"/> • EXTERNAL CONNECTION KIT FOR DETERGENT/RINSE AID PNC 922618 <input type="checkbox"/> • STACKING KIT FOR ELECTRIC 6 GN 2/1 OVEN ON ELECTRIC 6&10 GN 2/1 OVEN - H=120MM PNC 922621 <input type="checkbox"/> • TROLLEY FOR SLIDE-IN RACK FOR 6&10 GN 2/1 OVEN AND BLAST CHILLER FREEZER PNC 922627 <input type="checkbox"/> • TROLLEY FOR MOBILE RACK FOR 2 STACKED 6 GN 2/1 OVENS ON RISER PNC 922629 <input type="checkbox"/> • TROLLEY FOR MOBILE RACK FOR 6 GN 2/1 ON 6 OR 10 GN 2/1 OVENS PNC 922631 <input type="checkbox"/> • RISER ON FEET FOR STACKED 2X6 GN 2/1 OVENS PNC 922633 <input type="checkbox"/> • RISER ON WHEELS FOR STACKED 2X6 GN 2/1 OVENS - H=250MM PNC 922634 <input type="checkbox"/> • STAINLESS STEEL DRAIN KIT FOR 6&10 GN OVEN - DIA=50MM PNC 922636 <input type="checkbox"/> • PLASTIC DRAIN KIT FOR 6&10 GN OVEN - DIA=50MM PNC 922637 <input type="checkbox"/> • TROLLEY WITH 2 TANKS FOR GREASE COLLECTION PNC 922638 <input type="checkbox"/> • Grease collection kit for open base (2 tanks, open/close device and drain) PNC 922639 <input type="checkbox"/> • WALL SUPPORT FOR 6 GN 2/1 OVEN PNC 922644 <input type="checkbox"/> • DEHYDRATION TRAY - GN 1/1 H=20MM PNC 922651 <input type="checkbox"/> • DEHYDRATION TRAY - GN 1/1 FLAT PNC 922652 <input type="checkbox"/> • OPEN BASE FOR 6&10 GN 2/1 OVEN - DISASSEMBLED - NO ACCESSORY CAN BE FITTED WITH THE EXCEPTION OF 922384 PNC 922654 <input type="checkbox"/> • HEAT SHIELD FOR 6 GN 2/1 OVEN PNC 922665 <input type="checkbox"/> • HEAT SHIELD FOR STACKED OVENS 6 GN 2/1 ON 6 GN 2/1 PNC 922666 <input type="checkbox"/> • HEAT SHIELD FOR STACKED OVENS 6 GN 2/1 ON 10 GN 2/1 PNC 922667 <input type="checkbox"/> • FIXED TRAY RACK 5 GN 2/1 - 85MM PITCH PNC 922681 <input type="checkbox"/> • KIT TO FIX OVEN TO THE WALL PNC 922687 <input type="checkbox"/> • TRAY SUPPORT FOR 6&10 GN 2/1 OVEN BASE PNC 922692 <input type="checkbox"/> • 4 adjustable feet with black cover for 6 & 10 GN ovens, 100-115mm PNC 922693 <input type="checkbox"/> • WIFI BOARD (NIU) PNC 922695 <input type="checkbox"/> • HOLDER FOR DETERGENT TANK ON OPEN BASE PNC 922699 <input type="checkbox"/> • TRAY RACK WITH WHEELS 6 GN 2/1 - 65MM PITCH PNC 922700 <input type="checkbox"/> • MESH GRILLING GRID PNC 922713 <input type="checkbox"/> • PROBE HOLDER FOR LIQUIDS PNC 922714 <input type="checkbox"/> • ODOURLESS HOOD WITH FAN FOR 6&10 GN 2/1 ELECTRIC OVEN PNC 922719 <input type="checkbox"/> • CONDENSATION HOOD WITH FAN FOR 6&10GN 2/1 ELECTRIC OVEN PNC 922724 <input type="checkbox"/> | <ul style="list-style-type: none"> • EXHAUST HOOD WITH FAN FOR 6&10 GN 2/1 OVEN PNC 922729 <input type="checkbox"/> • EXHAUST HOOD WITHOUT FAN FOR 6&10 GN 2/1 OVEN PNC 922734 <input type="checkbox"/> • 4 HIGH ADJUSTABLE FEET FOR 6&10 GN OVENS - 230-290MM PNC 922745 <input type="checkbox"/> • TRAY FOR TRADITIONAL STATIC COOKING - H=100MM PNC 922746 <input type="checkbox"/> • DOUBLE-FACE GRIDDLE (RIBBED AND SMOOTH) FOR OVENS - 400X600MM PNC 922747 <input type="checkbox"/> • Trolley for grease collection kit PNC 922752 <input type="checkbox"/> • - NOT TRANSLATED - PNC 922773 <input type="checkbox"/> • Non-stick universal pan 1/1GN H=20mm PNC 925000 <input type="checkbox"/> • Non-stick universal pan 1/1GN H=40mm PNC 925001 <input type="checkbox"/> • Non-stick universal pan 1/1GN H=60mm PNC 925002 <input type="checkbox"/> • Frying griddle GN 1/1 for ovens PNC 925003 <input type="checkbox"/> • Aluminium oven grill GN 1/1 PNC 925004 <input type="checkbox"/> • FRYING PAN FOR 8 EGGS, PANCAKES, HAMBURGERS - GN 1/1 PNC 925005 <input type="checkbox"/> • FLAT BAKING TRAY WITH 2 EDGES - GN 1/1 PNC 925006 <input type="checkbox"/> • Potato baker GN 1/1 for 28 potatoes PNC 925008 <input type="checkbox"/> • COMPATIBILITY KIT FOR INSTALLATION ON PREVIOUS RANGE BASE GN 2/1 PNC 930218 <input type="checkbox"/> |
|---|---|

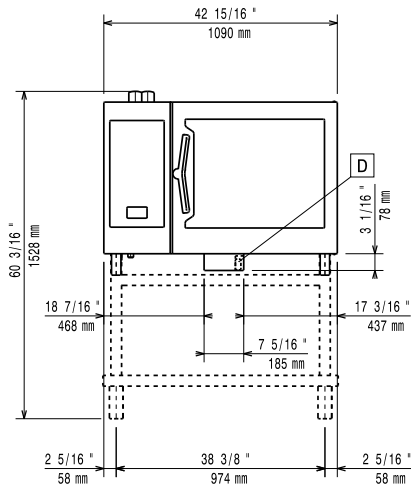
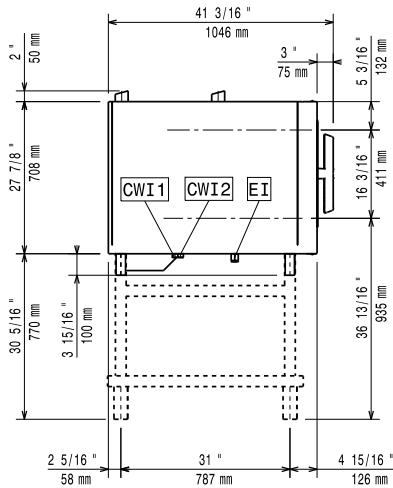
Front

Side

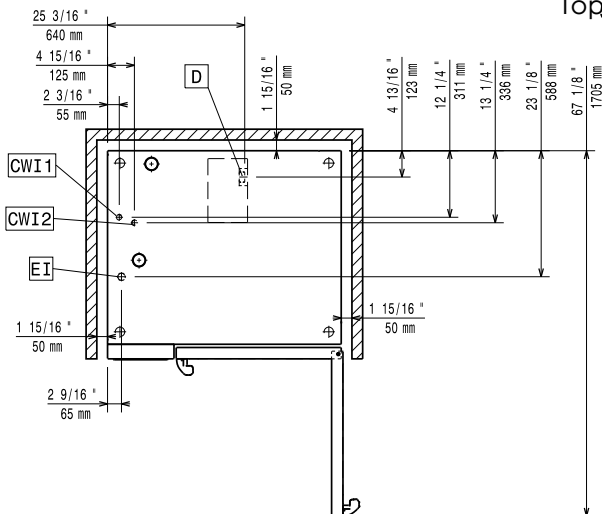
CWI1 = Cold Water inlet 1
 CWI2 = Cold Water Inlet 2
 D = Drain
 DO = Overflow drain pipe
 EI = Electrical inlet (power)

Top

Electric

Supply voltage:
 229731 (ECOE62T3S0) 400-430 V/3N ph/50-60 Hz
Electrical power, default: 21.4 kW
Electrical power max.: 22.3 kW

Water:

Water inlet "FCW" connection: 3/4"
Pressure, bar min/max: 1-4.5 bar
Drain "D": 50mm
Max inlet water supply temperature: 30 °C
Chlorides: <17 ppm
Conductivity: >285 µS/cm
 Electrolux recommends the use of treated water, based on testing of specific water conditions.
 Please refer to user manual for detailed water quality information.

Installation:

Clearance: Clearance: 5 cm rear and right hand sides.
Suggested clearance for service access: 50 cm left hand side.

Capacity:

GN: 6 - 2/1 Gastronorm
Max load capacity: 60 kg

Key Information:

Door hinges: Right Side
External dimensions, Width: 1090 mm
External dimensions, Height: 808 mm
External dimensions, Depth: 971 mm
Weight: 148.5 kg
Net weight: 148.5 kg
Shipping weight: 171.5 kg
Shipping volume: 1.27 m³