

MULTI-FUNCTIONAL HAND TRUCK

US210E/US210G



Dual-mode Design



Energy Efficient



Various Functions



■ One Machine for Two Purposes - Easy Switching

US210E/US210G is a dual-mode design hand truck, which can switch to a powered stair climber and hand truck in seconds, it can meet the handling need in all kinds of scenarios.

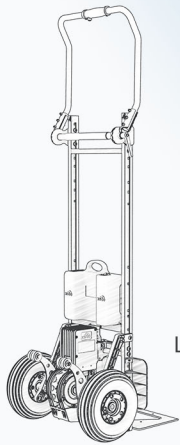

Motorized



Labor Saving



Stair Climber Mode

Battery powered stair climbing function save labor effort, meet needs of various scenario of up/down stairs

Dual Mode · More Versatile · More Advantageous

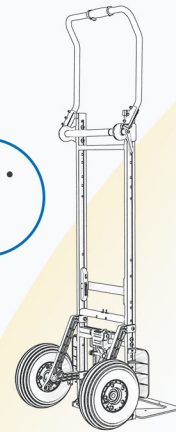

Lightweight



Easy to Carry

5s
to Switch



Hand Truck Mode

Lightweight body, pneumatic tires, flexible steering, and easy operation



Powerful



Lightweight and Easy to Carry



Efficient



Flexible Operation

Product Structure



Core Component - SE210 Drive System Assembly (Detachable)

Self-developed powertrain, with detachable design, can be quickly switched between two modes.

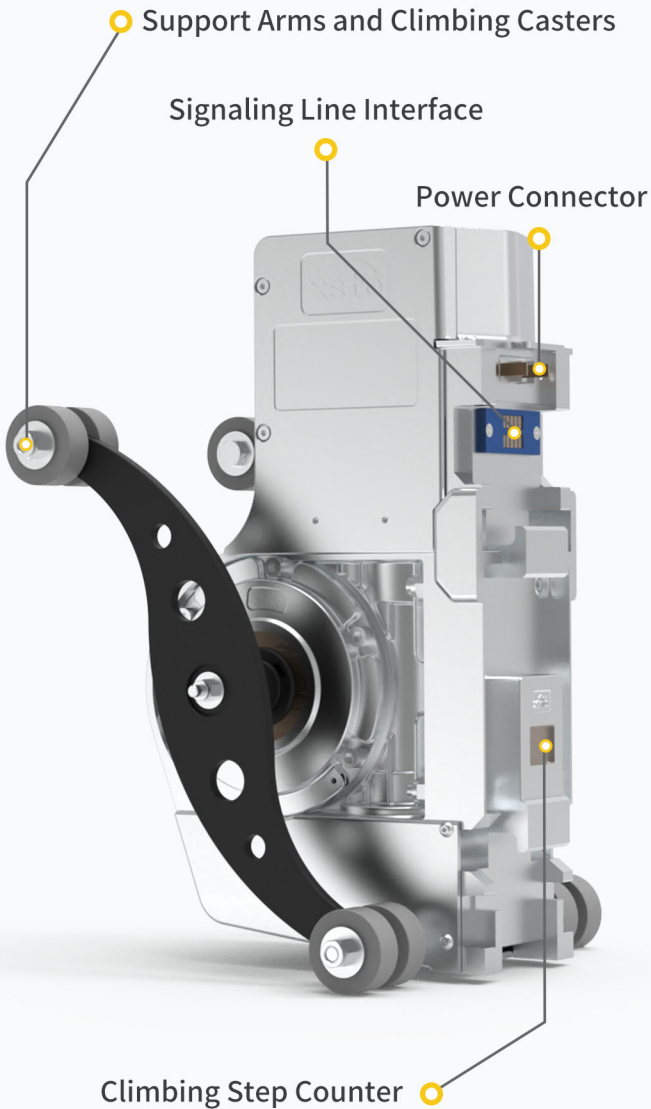

Convenient Disassembly and Installation

The whole unit can be quickly disassembled and installed



Aluminium Cover

Integrated casting, impact and scratch resistant, long service life



Energy Efficient

Compact structure, space and power saving, high efficiency output



Good Heat Dissipation

Unique heat dissipation structure



Split Design

Each module area is independent, clear function, easy to maintain

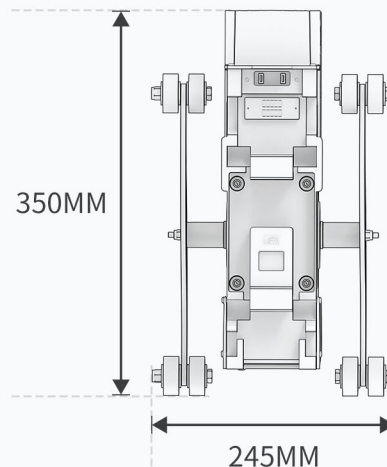
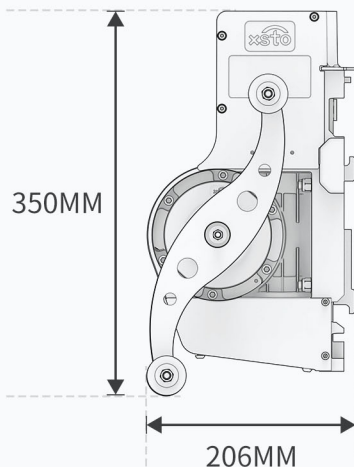

Weight of Parts
12.5KG

Technical Parameters

Model No.	US210E	US210G
Product Weight (Stair Climber Mode)	26KG	28.5KG
Product Weight (Hand Truck Mode)	13.5KG	16KG
Maximum Load	210KG	210KG
Climbing Speed	Low Speed: 22 Steps/Min High Speed: 30 Steps/Min	Low Speed: 22 Steps/Min High Speed: 30 Steps/Min
Battery Capacity	Approx. 90-121 Floors (1620-1944 Steps)	Approx. 90-121 Floors (1620-1944 Steps)
Brake System	No	Yes
Maximum Step Height	210MM	210MM
Noise Level	<70dB	<70dB
Protection Level	IP54	IP54

Product Size				
	<p>Expanded</p>		<p>Folded</p>	

Product Accessories



Lithium Ion Battery

Battery Parameter: 48V10AH

Battery Weight: 3.2KG



Charger

Charger Input: AC100V-240V

Charger Output: DC54.6V4A



Belt

Size: 55 × 3700MM

Adjustable Strap Fastening Buckle

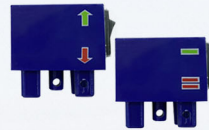

Spare Switch

Up / Down Switch

High / Low Speed Switch



Ease Your Way to Anywhere

