

BAKEWISE

professional bakery equipment

SINMAG HORIZONTAL SLICER "TAGLIO" (HS2-3S)

The **Sinmag TAGLIO** horizontal slicer is a compact floor model with lockable castors

It has been designed to slice cakes and hamburger buns including bagels and rolls etc.

The top conveyor on the machine – is **entirely adjustable to speed and height**, transports the product directly to the cutting knives.

The distance between the two cutting blades can be adjusted easily to adapt per steps of 5mm, and can be used for slicing the products in different layers at the same time!

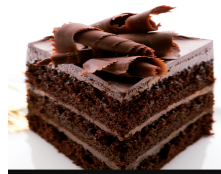

| | |
|-----------------------------|--------------------|
| MAX PRODUCT HEIGHT | 90 mm |
| CONVEYOR SPEED | 2.5 --> 16cm / sec |
| NUMBER OF KNIVES | 3 |
| DISTANCE BETWEEN THE BLADES | 5 - 90 mm |
| CONVEYOR BELT WIDTH | 405 mm |
| NET WEIGHT MACHINE | 205 kg |
| MOTOR POWER | 0,525 kW |
| VOLTAGE | 230V 1Ph |

BAKEWISE

professional bakery equipment

SINMAG HORIZONTAL SLICER "TAGLIO" (HS2-3S)

SINMAG



SIDE VIEW

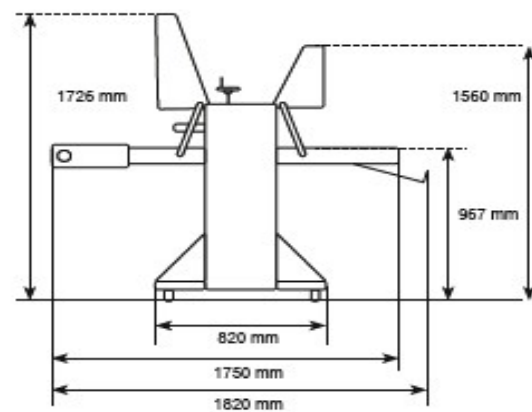

FRONT VIEW

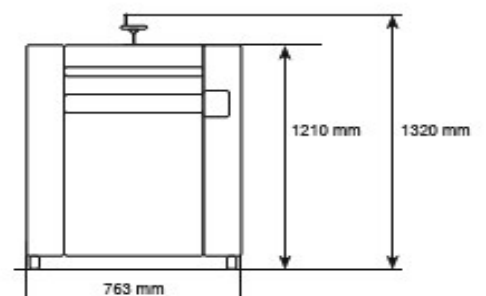

Belt cleaning system. T.

