



Almega Friendly series II

High-Payload Robot

NEW FD-B100

100kg payload hollow arm Multipurpose robot



The hollow wrist and shoulder
make cables mounted neatly.

Highest level of operating
range in the class

PICKING	SPOT WELDING
CUTTING	Used for... ASSEMBLY
LOAD/ UNLOAD	FINISHING
ARC WELDING	SORTING

High-density layout

- Slim design avoids interference with robots and Jigs
- Wide operating range and narrow interference radius

Reducing cycle time

- Top level speed in the class

Easy communication with peripherals

- Support with application cables of various communication standards
- Built-in cable from robot base to shoulder

[Manipulator Working Range]

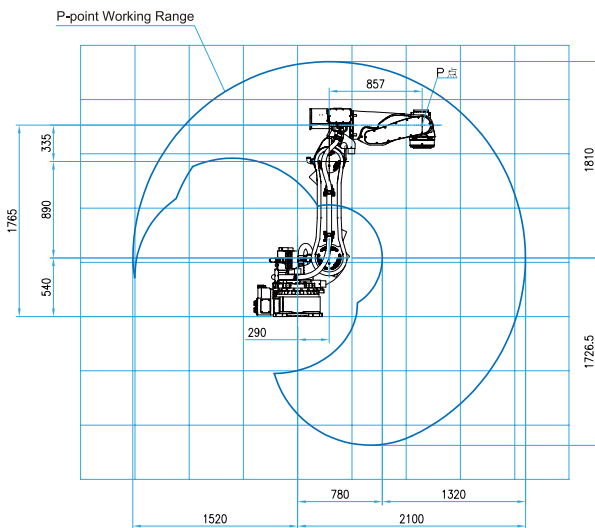
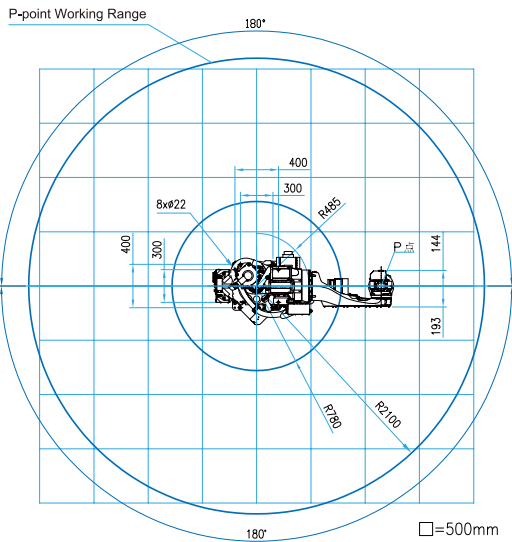

[Manipulator Specifications]

		Specification	
Name		NB100	
Structure		Vertically articulated type	
Number of Axes		6	
Wrist Capacity		100kg	
Positional Repeatability (Note 1)		±0.06mm (Note 1)	
Driving Method		AC servo motor	
Driving Capacity		16kW	
Positional Feedback		Absolute encoder	
Working Range	Arm	J1 (Rotation)	±180°
		J2 (Front/back)	-155° ~ +90°
		J3 (Up/down)	-185° ~ +170°
	Wrist	J4 (Swing)	±210°
		J5 (Bending)	-35° ~ +215°
		J6 (Twist)	±210°
Maximum Speed	Arm	J1 (Rotation)	2.44 rad/s {140° /s}
		J2 (Front/back)	1.92 rad/s {110° /s}
		J3 (Up/down)	2.44 rad/s {140° /s}
	Wrist	J4 (Swing)	3.58 rad/s {205° /s}
		J5 (Bending)	3.67 rad/s {210° /s}
		J6 (Twist)	5.67 rad/s {325° /s}
Wrist Allowable Load	Allowable Moment	J4 (Rotation)	650 N·m
		J5 (Swing)	650 N·m
		J6 (Twist)	294 N·m
	Allowable Moment of Inertia	J4 (Rotation)	60 kg·m ²
		J5 (Swing)	60 kg·m ²
		J6 (Twist)	33.7 kg·m ²
Arm Cross-sectional Area		6.21 m ² × 360°	
Environmental Conditions		Temp: 0~45°C, Hmd: 20~80%RH (No Condensation)	
Mass (weight)		793 kg	
Capacity of Upper Arm		50 kg (Note 2)	
Installation Method		Floor-/Ceiling-	
Paint Color		White (Munsell notation 10GY 9/1)	

Notes

1. Positional repeatability of the tool center point (TCP) value complies with the JIS-8-8432 Standard.
2. The capacity of the upper arm varies with the wrist capacity.
3. The positional data of absolute encoder is backed up by the battery. The battery backup period with the primary power OFF is approx 3 years. Exceeding this period will require the battery replacement and the absolute offset adjustments.
4. The battery backup period may be shorter depending on the surrounding environment and usage conditions.
5. Holding brakes are provided on all axes.



Daihen Robot Site

www.daihen-robot.com/en/

DAIHEN Corporation

4-1, Koyochonishi, Higashinada-ku, Kobe, Hyogo 658-0033, Japan

Phone: (Country Code 81) 78-275-2006

Fax: (Country Code 81) 78-845-8159

Note This product and the technologies (including software) used in the product are subject to Catch-All Controls. When exporting any of them, verify the users, applications, etc. according to the applicable laws and regulations and take appropriate procedures such as applications for export permission to the Minister of Economy, Trade and Industry if required.

●The information contained in this catalog is current as of March 2021 and is subject to revision without notice.