



In-line manual weighing scale

The ESTEVE weighing scale enables you to manually weigh micro-ingredients. It displays the instructions stored in the recipe's database, which is hosted in the PC and communicates the data via the field bus.

Application

For all types of ingredients : powders and liquids.

Advantages

- Simple, fast and precise dosage process
- Traceable manual operations
- Direct data transfer to your process control system (Profibus, etc.)
- Tolerance control
- Predefined, automatic tare
- Memorisation of thousands of product sheets.
- Time and printing saving for monitoring the traces.

Operating principle

The manual weighing scale guarantees precise in-line dosage. It is fitted with an HMI connected to the main network.

According to the recipe in progress, the operator views the various ingredients and their weight to be manually added to the recipe.

Guided step-by-step by the HMI, the operator selects each product to be dosed by the batch number or by using a bar code reader. The system then checks that the weight of the dosed product falls within the defined tolerance.

Each step is validated. After each weighing, added to the recipe and validated by the operator, the following ingredient to be dosed is automatically displayed.

Step by step, no material can be forgotten in the recipe and the weight of each product is controlled. All these steps are then detailed in the traceability sheets.

Micro ingredient – manual dosing

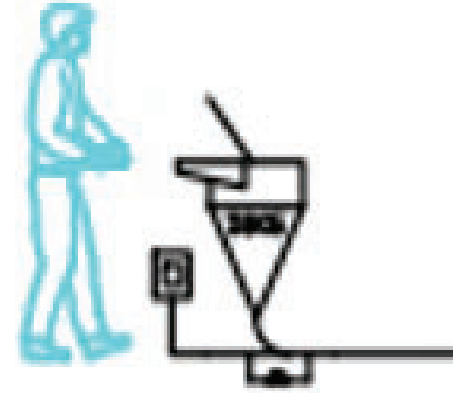

Manual weighing scale with Touch screen panel for recipes traceability

- Manual preparation of the ingredients
- Daily preparation of the premix
- Tipping station for premix.

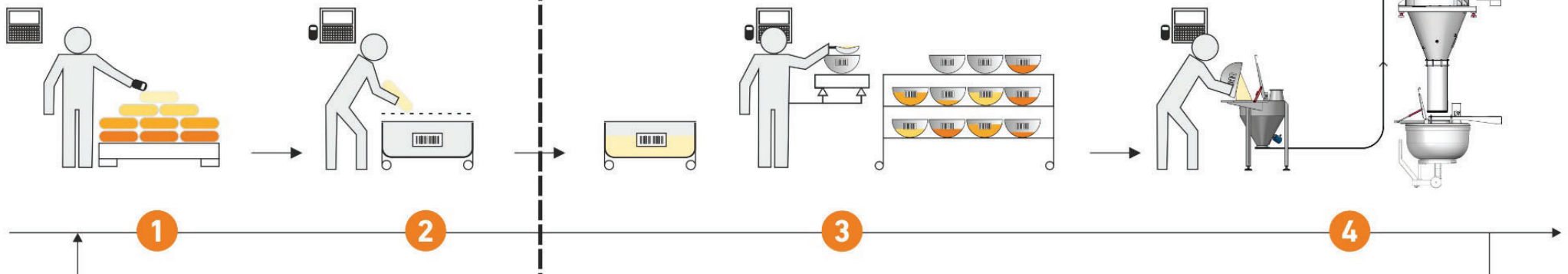

SEMI AUTOMATED SYSTEM FOR MINOR INGREDIENTS



Preparation table in Stainless Steel

- Easy dosing system, fast and accurate
- Traceability of manual steps
- Tolerance control
- Predefined / automatic tare
- Storage of thousands product pages

- Sliding weighing scale
- Touch screen panel on a moving arm
- Minor ingredients bins storage
- Trolleys to bring the premix to the production area

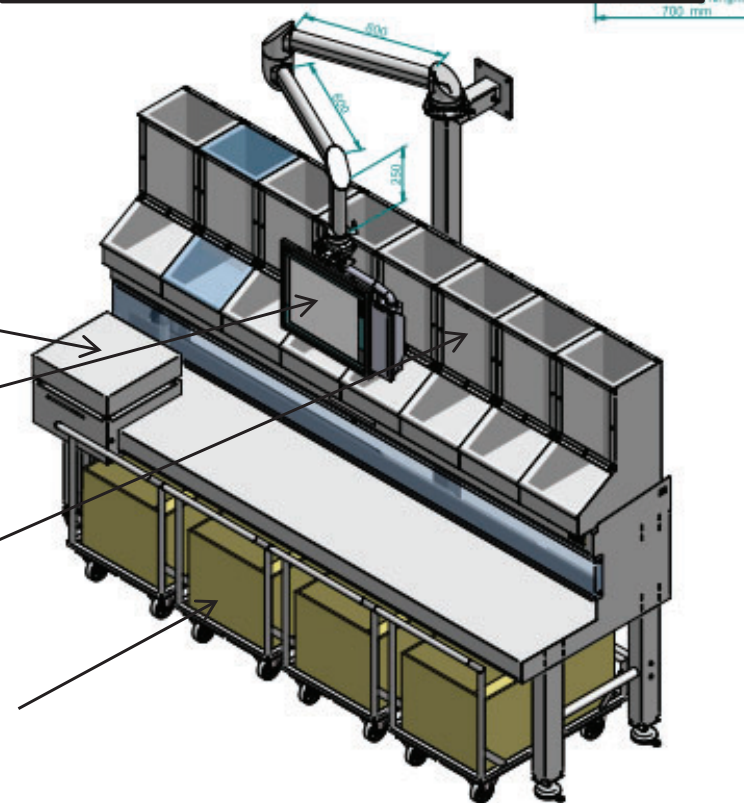

Micro ingredient – manual dosing

