

# DP15

# DRILL PRESS



# Bäumr-AG®

## User Manual

[Revision 1.0 July 2022]

READ THIS MANUAL CAREFULLY BEFORE USE – FAILURE TO DO SO MAY RESULT IN INJURY, PROPERTY DAMAGE AND MAY VOID WARRANTY. • KEEP THIS MANUAL FOR FUTURE REFERENCE. • Products covered by this manual may vary in appearance, assembly, inclusions, specifications, description, and packaging.

# Safety

Safety messages are designed to alert you to possible dangers or hazards that could cause death, injury or equipment or property damage if not understood or followed. Safety messages have the following symbols:



You **WILL** be **KILLED** or **SERIOUSLY INJURED** if you do not follow instructions.



You **CAN** be **KILLED** or **SERIOUSLY INJURED** if you do not follow instructions.



You **CAN** be **INJURED** if you do not follow instructions or equipment damage may occur.

It is vital that you read and understand this user manual before using the product, including safety warnings, and any assembly and operating instructions. Keep the manual for future reference.

Safety precautions and recommendations detailed here must be fully understood and followed to reduce the risk of injury, fire, explosion, electrical hazard, and/or property damage.

Safety information presented here is generic in nature – some advice may not be applicable to every product. The term "equipment" refers to the product, be it electrical mains powered, battery powered or combustion engine powered.

- **Before Use** - If you are not familiar with the safe operation/handling of the equipment or are in any way unsure of any aspect of suitability or correct use for your application, you should complete training conducted by a person or organization qualified in safe use and operation of this equipment, including fuel/electrical handling and safety.
- Do NOT operate the equipment in flammable or explosive environments, such as in the presence of flammable liquids, gases, or dust. The equipment may create sparks or heat that may ignite flammable substances.
- Keep clear of moving parts.
- Equipment may be a potential source of electric shock or injury if misused.
- Do NOT operate the equipment if it is damaged, malfunctioning or is in an excessively worn state.
- Do NOT allow others to use the equipment unless they have read this manual and are adequately trained.
- Keep packaging away from children - risk of suffocation! Operators must use the equipment correctly. When using the equipment, consider conditions and pay due care to persons and property.

## General Work Area Safety

- Work areas should be clean and well lit.
- Do not operate the equipment if bystanders, animals etc are within operating range of the equipment or the general work area.
- If devices are provided for connecting dust extraction / collection facilities, ensure these are connected and used properly. Dust collection can reduce dust-related hazards.

## General Personal Safety

- Wear appropriate protective equipment when operating, servicing, or when in the operating area of the equipment to help protect from eye and ear injury, poisoning, burns, cutting and crush injuries. Protective equipment such as safety goggles, respirators, non-slip safety footwear, hard hat, hearing protection etc should be used for appropriate equipment / conditions. Other people nearby should also wear appropriate personal protective equipment. Do not wear loose clothing or jewellery, which can be caught in moving parts. Keep hair and clothing away from the equipment.
- Stay alert and use common sense when operating the equipment. Do not over-reach. Always maintain secure footing and balance.
- Do not use the equipment if tired or under the influence of drugs, alcohol, or medication.
- This equipment is not intended for use by persons with reduced physical, sensory, or mental capabilities.

## General Fuel Safety

- Petrol/fuel/gasoline is extremely flammable – keep clear of naked flames or other ignition sources.
- Do not spill fuel. If you spill fuel, wipe it off the equipment immediately – if fuel gets on your clothing, change clothing.
- Do NOT smoke near fuel or when refuelling.
- Always shut off the engine before refuelling.
- Do NOT refuel a hot engine.
- Open the fuel cap carefully to allow any pressure build-up in the tank to release slowly.
- Always refuel in well ventilated areas.
- Always check for fuel leakage. If fuel leakage is found, do not start, or run the engine until all leaks are fixed.

## General Carbon-Monoxide Safety

- Using a combustion engine indoors **CAN KILL IN MINUTES**. Engine exhaust contains carbon-monoxide – a poison you cannot smell or see.
- Use combustion engines **OUTSIDE** only, and far away from windows, doors, and vents.

## General Equipment Use and Care

- The equipment is designed for domestic use only.
- Handle the equipment safely and carefully.
- Before use, inspect the equipment for misalignment or binding of moving parts, loose components, damage, or any other condition that may affect its operation. If damaged, have the equipment repaired by an authorised service centre or technician before use.
- Prevent unintentional starting of the equipment - ensure equipment and power switches are in the OFF position before connecting or moving equipment. Do not carry equipment with hands or fingers touching any controls. Remove any tools or other items that are not a part of the equipment from it before starting or switching on.
- Do not force the equipment. Use the correct equipment for your application. Equipment will perform better and be safer when used within its design and usage parameters.
- Use the equipment and accessories etc. in accordance with these instructions, considering working conditions and the work to be performed. Using the equipment for operations different from those intended could result in hazardous situations.
- Always keep equipment components (engines, hoses, handles, controls, frames, housings, guards etc) and accessories (cutting tools, nozzles, bits etc) properly maintained. Keep the equipment clean and, where applicable, properly lubricated.
- Store the equipment out of reach of children or untrained persons. To avoid burns or fire hazards, let the equipment cool completely before transporting or storing. Never place or store the equipment near flammable materials, combustible gases, or liquids etc.
- The equipment is not weather-proof, and should not be stored in direct sunlight, at high ambient temperatures or locations that are damp or humid.
- Do not clean equipment with solvents, flammable liquids, or harsh abrasives.
- For specific equipment safety use and care, see Equipment Safety.

**General Electrical Safety**

- Inspect electrical equipment, extension cords, power bars, and electrical fittings for damage or wear before each use. Repair or replace damaged equipment immediately.
- Ensure all power sources conform to equipment voltage requirements and are disconnected before connecting or disconnecting equipment.
- When wiring electrically powered equipment, follow all electrical and safety codes.
- Wherever possible, use a residual current device (RCD).
- High voltage / high current power lines may be present. Use extreme caution to avoid contact or interference with power lines. Electrical shock can be fatal.

**General Electrical Safety**

- Electrically grounded equipment must have an approved cord and plug and be connected to a grounded electrical outlet.
- Do NOT bypass the ON/OFF switch and operate equipment by connecting and disconnecting the electrical cord.
- Do NOT use equipment that has exposed wiring, damaged switches, covers or guards.
- Do NOT use electrical equipment in wet conditions or in damp locations.
- Do NOT use electrical cords to lift, move or carry equipment.
- Do NOT coil or knot electrical cords, and ensure electrical cords are not trip hazards.

**General Service Information**

- The equipment must be serviced or repaired at authorised service centres by qualified personnel only.
- Replacement parts must be original equipment manufacturer (OEM) to ensure equipment safety is maintained.
- Do NOT attempt any maintenance or repair work not described in this manual.
- After use, the equipment and components may still be hot – allow the equipment to cool and disconnect spark plugs and/or electrical power sources and/or batteries from it before adjusting, changing accessories, or performing repair or maintenance.
- Do NOT adjust while the equipment is running.
- Perform service-related activities in suitable conditions, such as a workshop.
- Replace worn, damaged or missing warning/safety labels immediately.

**Application Conditions**

This drill press is designed for operating under ambient temperatures between +5°C and 40°C and for installation at altitudes no more than 1000m above M.S.L. The surrounding humidity should be less than 50% at 40°C. It can be stored or transported under ambient temperatures between -25°C and 55°C.

**Recycling and Disposal**

This marking indicates that this product should not be disposed with other household wastes. To prevent possible harm to the environment or human health from uncontrolled waste disposal, recycle it responsibly to promote the sustainable reuse of material resources. To return your used device, please use the return and collection systems or check with your local authority or local stores for advice of environmentally safe recycling.

**Understand your Machine**

- Read this manual and labels affixed to the machine to understand its limitations and potential hazards.
- Be thoroughly familiar with the controls and their proper operation. Know how to stop the machine and disengage the controls quickly.
- Do not attempt to operate the machine until you fully understand how to properly operate and maintain the engine and how to avoid accidental injuries and/or property damage.
- If the unit is to be used by someone other than original purchaser or loaned, rented, or sold, always provide this manual and any needed safety training before operation. The user can prevent and is responsible for accidents or injuries that may occur to themselves, other people, and property.
- Do not force the machine. Use the correct machine for your application. The correct machine will do the job more efficiently and safer at the rate it was designed.

**Personal Safety**

- Do not permit children to operate this machine at any time.
- Keep children, pets, and other people not using the unit away from the work area. Be alert and shut off unit if anyone enters work area. Keep children under the watchful care of a responsible adult.
- Do not operate the machine while under the influence of drugs, alcohol, or any medication that could affect your ability to use it properly.
- Dress properly. Wear heavy long pants, boots, and gloves. Do not wear loose clothing, short pants, or jewellery of any kind. Secure long hair so it is above shoulder level. Keep your hair, clothing, and gloves away from moving parts. Loose clothes, jewellery, or long hair can be caught in moving parts.
- Protect eyes, face, and head from objects that may be thrown from the unit. Always wear safety goggles or safety glasses with side shields when operating.
- Wear appropriate hearing protection. Wear respiratory protection to avoid the risk of inhaling harmful dust.
- Always keep hands and feet away from all moving parts during operation. Moving parts can cut or crush body parts.
- Always keep hands and feet away from all pinch points.
- Do not touch parts that might be hot from operation. Allow parts to cool before attempting to maintain, adjust, or service.
- Stay alert, watch what you are doing, and use common sense when operating the machine.
- Do not overreach. Do not operate the machine while barefoot or when wearing sandals or similar lightweight footwear. Wear protective footwear that will protect your feet and improve your footing on slippery surfaces. Keep proper footing and balance at all times. This enables better control of the machine in unexpected situations.

**Inspect your Machine**

- Check your machine before starting it. Keep guards in place and in working order. Make sure all nuts, bolts, etc., are securely tightened.

- Never operate the machine when it needs repair or is in poor mechanical condition. Replace damaged, missing, or failed parts before using it. Keep the machine in safe working condition. Regularly check to see that the keys and adjusting wrenches are removed from the machine area before starting it. A wrench or a key that is left attached to a rotating part of the machine may result in personal injury. Avoid accidental starting. Be sure the motor switch is off before transporting the machine or performing any maintenance or service on the unit.
- Transporting or performing maintenance or service on a machine with its switch on invites accidents. If the machine should start to vibrate abnormally, stop the motor, and check immediately for the cause. Vibration is generally a warning sign of trouble.

#### Electric Safety

- Protect yourself from electric shock. Do not plug or unplug the motor while standing in or around damp or wet ground. Do not use the unit in wet or damp areas or expose it to rain. Prevent body contact with grounded surfaces: pipes, radiators, ranges, and refrigerator enclosures. Make sure your fingers do not touch the plug's metal prongs when plugging or unplugging the unit.
- Avoid inadvertent starting. Make sure that the switch is switched off when plugging the plug into an outlet.
- Only use approved and appropriately identified extension cables for use outdoors. Only use cable reels in the unrolled state.
- Do not use the cable for purposes for which it is not intended. Do not use the cable to pull the plug out of the outlet. Protect the cable from heat, oil, and sharp edges.
- Have your electric tool repaired by a qualified electrician. This electric tool conforms to the applicable safety regulations. Repairs may only be performed by an electrician using original spare parts. Otherwise, accidents can occur.

#### Work Area & Store Area

- Keep the work area orderly. Disorder in the work area can lead to accidents.
- Take environmental influences into account. Do not expose electric tools to rain. Do not use electric tools in a damp or wet environment. Make sure that the work area is well-illuminated. Do not use electric tools where there is a risk of fire or explosion.
- Securely store unused electric tools. Unused electric tools should be stored in a dry, elevated or closed location out of the reach of children.

#### Machine Use and Care

- Never turn the drill press on until the table is clear of all foreign objects (tools, scraps, etc.).
- Always keep hands and fingers away from the drill bit.
- Do not drill materials without a flat surface.
- Never start the drill press with the drill bit pressed against the workpiece.
- Make sure the table lock is tightened before starting the drill press.
- Never layout, assemble, or set-up any work on the table while the drill is on.
- Make sure the drill bit is securely locked in the chuck.
- Make sure the chuck key is removed from the chuck before turning power on.
- Adjust the table or depth stop to avoid drilling into the table.
- Always stop the drill before removing scrap pieces from the table.
- Use clamps or a vise to secure a workpiece to the table. This will prevent the workpiece from rotating with the drill bit.
- Do not wear gloves when operating a drill press.
- Set the drill press to the speed that is appropriate for the material being drilled.
- If any part of the drill press is missing/ damaged or if the electrical components fail to perform properly, shut the power OFF and unplug the drill press. Replace missing, damaged, or failed parts before resuming operation.
- Before leaving the machine, shut the power off, remove the drill bit and clean the table.
- Take care of your tools. Keep cutting tools sharp and clean to be able to work better and more safely. Follow the instructions for lubrication and for tool replacement. Check the connection cable of the electric tool regularly and have it replaced by a recognized specialist when damaged. Check extension cables regularly and replace them when damaged. Keep the handle dry, clean, and free of oil and grease.

#### Residual Risks

Despite proper use, additional residual risks cannot be completely ruled out. The following risks may arise due to the nature of the drill press.

##### **Mechanical hazards related to machine parts or workpieces:**

- Shape
- Relative location
- Mass and velocity (kinetic energy of elements in controlled or uncontrolled motion)
- Mechanical strength
- Crushing hazard
- Cutting or severing hazard
- Entanglement hazard
- Drawing-in or trapping hazard

##### **Electrical hazards due to:**

- Contact of persons with live parts (direct contact)
- Contact of persons with parts which have become live under faulty conditions (indirect contact)
- Electrostatic phenomena

##### **Hazards generated by noise, resulting in:**

- Hearing loss (deafness), other physiological disorders (loss of balance, loss of awareness)

- Interference with speech communication, acoustic signals.

**Hazards generated by materials and substances (and their constituent elements)**

- Processed or used by the machinery
- Hazards from contact with or inhalation of harmful fluids and dusts
- Fire hazard

**Hazards generated by neglecting ergonomic principles in machinery design related to:**





















- Unhealthy postures or excessive effort
- Hand-arm or foot-leg anatomy
- Local lighting
- Mental overload and underload, stress
- Human error, human behaviour
- Design, location, or identification of manual controls















**Combination of hazards. Unexpected start up, unexpected overrun/overspeed (or any similar malfunction) from:**

- Failure/disorder of the control system
- External influences on electrical equipment
- Errors made by the operator (due to mismatch of machinery with human characteristics and abilities)
- Impossibility of stopping the machine in the best possible conditions
- Variations in the rotational speed of tools
- Failure of the power supply
- Failure of the control circuit
- Errors of fitting
- Break-up during operation
- Falling or ejected objects or fluids
- Loss of stability / overturning of machinery

# Safety Symbols

The product may have safety warning labels attached to it, explained below. Understand the symbols on your product and their meanings. If any stickers become unreadable, unattached etc., replace them.

 <p><b>Flammable Material Hazard</b> Flammable liquids, gases, or substances etc may present. Avoid ignition sources and open flames. Danger of fire.</p>	 <p><b>Read User Manual</b> Read and fully understand product safety warnings, operation, procedures etc before using the product.</p>	 <p><b>Use Hand Protection</b> Wear appropriate hand protection and take due care as the product or use of the product may present hand hazards.</p>	 <p><b>Carbon-Monoxide Hazard</b> Do not use the product in confined areas or without adequate ventilation. Carbon-monoxide poisoning can be fatal.</p>
 <p><b>Electrocution / Electrical Shock Hazard</b> High voltage or high current electricity may be present or required by the product. Take due care when handling electrical products, cables, plugs and leads. Electrical shock can be fatal.</p>	 <p><b>Toxic Fumes / Dust Hazard</b> Using the product or by-products from use may produce fumes, smoke or particles that could be harmful if inhaled. Wear appropriate breathing protection and have adequate ventilation.</p>	 <p><b>Explosive Material Hazard</b> Combustible liquids, gases, or substances etc may be present. Avoid ignition sources and open flames. Danger of explosion.</p>	 <p><b>Cutting / Amputation Hazard</b> The product may have blades, edges or mechanical devices that can cause severe cut injury to fingers, limbs etc. Take due care when handling and using the product.</p>
 <p><b>Crush Hazard</b> The product may have blades, edges or mechanical devices that can cause severe crush injury to fingers, limbs etc. Take due care when handling and using the product.</p>	 <p><b>Single Operator Only</b> The product must be operated by a single person only. More than one person operating the product may introduce additional hazards.</p>	 <p><b>Use Face Protection</b> Wear appropriate full-face protection and take due care as the product or use of the product may present face and eye hazards.</p>	 <p><b>Use Foot Protection</b> Wear appropriate foot protection and take due care as the product or use of the product may present foot hazards.</p>
 <p><b>Use Eye / Ear / Head Protection</b> Wear appropriate eye and / or ear and / or head protection and take due care as the product or use of the product may present eye, hearing, and head hazards.</p>	 <p><b>Running Hazard</b> Do not run on or near the product as doing so may present a fall hazard.</p>	 <p><b>Diving Hazard</b> Do not dive into the product as doing so may present a neck / head injury hazard.</p>	 <p><b>Adult Supervision Required</b> Always supervise children and other users of a product to prevent drowning or injury.</p>
 <p><b>Skin Penetration / Puncture Hazard</b> The product may produce pressure, emit liquids or objects that can cause severe injury to fingers, limbs, blood etc. Take due care when handling and using the product.</p>	 <p><b>Hot Surface Hazard</b> Be aware that the product may produce high temperatures and hot surfaces that can cause burn injuries.</p>	 <p><b>Flying Debris Hazard</b> Be aware that the product or use of the product may present hazards produced by flying debris. Wear appropriate clothing and protective devices.</p>	 <p><b>Moving Parts Hazard</b> Be aware that the product contains or uses mechanical devices that move or rotate. Always wait for moving parts to stop fully before handling the product, adjusting, maintenance etc.</p>

 <p><b>Carbon-Monoxide Hazard</b> Do not use the product in confined areas or without adequate ventilation. Carbon-monoxide poisoning can be fatal.</p>	 <p><b>Pull Hazard</b> Be aware that the product contains or uses mechanical devices that can pull in objects and can cause severe injury to fingers, limbs etc. Take due care when handling and using the product.</p>	 <p><b>Slope / Fall Injury Hazard</b> Be aware that using the product on sloping surfaces or in slippery conditions may present additional dangers from falls and contact with blades, moving parts, hot surfaces etc.</p>	 <p><b>"Slam Dunk" Warning</b> Do NOT attempt "slam dunk" manoeuvres as this may result in severe injury due to falling, product breakage or collapse etc.</p>
 <p><b>Electrocution / Electrical Shock Hazard - Outdoor</b> High voltage or high current electricity may be present or required by the product. Do NOT use in rain, damp, or wet conditions. Electrical shock can be fatal.</p>	 <p><b>Electrocution / Electrical Shock Hazard - Disconnect</b> High voltage or high current electricity may be present or required by the product. Always disconnect the product from the electrical supply before handling the product, adjusting, maintenance etc.</p>	 <p><b>Power Line Electrocution Hazard</b> High voltage / high current power lines may be present. Use extreme caution to avoid contact or interference with power lines. Electrical shock can be fatal.</p>	 <p><b>"Kick-Back" Hazard</b> High level of "kick-back" hazard that can cause the machine to suddenly rotate towards operator. Kick-back injury can be fatal.</p>
 <p><b>Winch Operator Position Hazard</b> Do NOT stand between winch and load. Do NOT use winch to move people.</p>	 <p><b>Winch Lift Hazard</b> Do NOT LIFT load vertically. Use machine to PULL only.</p>	 <p><b>Cable Hazard</b> Ensure that load bearing cable is not kinked or knotted.</p>	 <p><b>Winch Cable Hazard</b> Ensure that there is a minimum number of cable coils on winching mechanism.</p>
 <p><b>Winch Hook Hazard</b> Carry hook to load – do NOT throw or run.</p>	 <p><b>Flash / Blinding Hazard</b> Wear appropriate eye protection for welding. Direct exposure to weld arcs may cause permanent eye injury.</p>	 <p><b>Laser Hazard</b> Laser may be in use – do NOT look directly at laser or allow others to.</p>	

# Table of Contents

<b>Safety</b> .....	<b>2</b>
Safety Symbols .....	6
<b>Contents Supplied</b> .....	<b>9</b>
<b>Assembly</b> .....	<b>10</b>
Column Tube .....	10
Drilling Bench .....	11
Machine Head .....	14
Drill Chuck Guard .....	15
Drill Chuck .....	16
Drill Lifting Arms .....	17
Drill Chuck Key .....	18
Depth Stop .....	19
Plier (Optional- Sold Separately) .....	20
<b>Features and Controls</b> .....	<b>21</b>
<b>Set-Up</b> .....	<b>22</b>
Selecting the Speed .....	22
Tensioning the V-belts.....	24
Adjusting the Drilling Bench.....	25
Changing the Drill Bit.....	28
<b>Operation</b> .....	<b>29</b>
Drilling .....	29
General Drilling Guidelines - Drilling A Hole .....	29
Drilling Metal.....	29
Drilling Wood .....	30
Emergency Stop Switch .....	30
<b>Maintenance</b> .....	<b>31</b>
Servicing.....	31
Cleaning .....	31
<b>Transportation and Storage</b> .....	<b>32</b>
Transportation .....	32
Storage.....	32
<b>Troubleshooting</b> .....	<b>33</b>
<b>Specifications</b> .....	<b>35</b>



# Contents Supplied

The drill press comes partially assembled and is shipped in carefully packed carton. After all the parts have been removed from the carton, you should have:

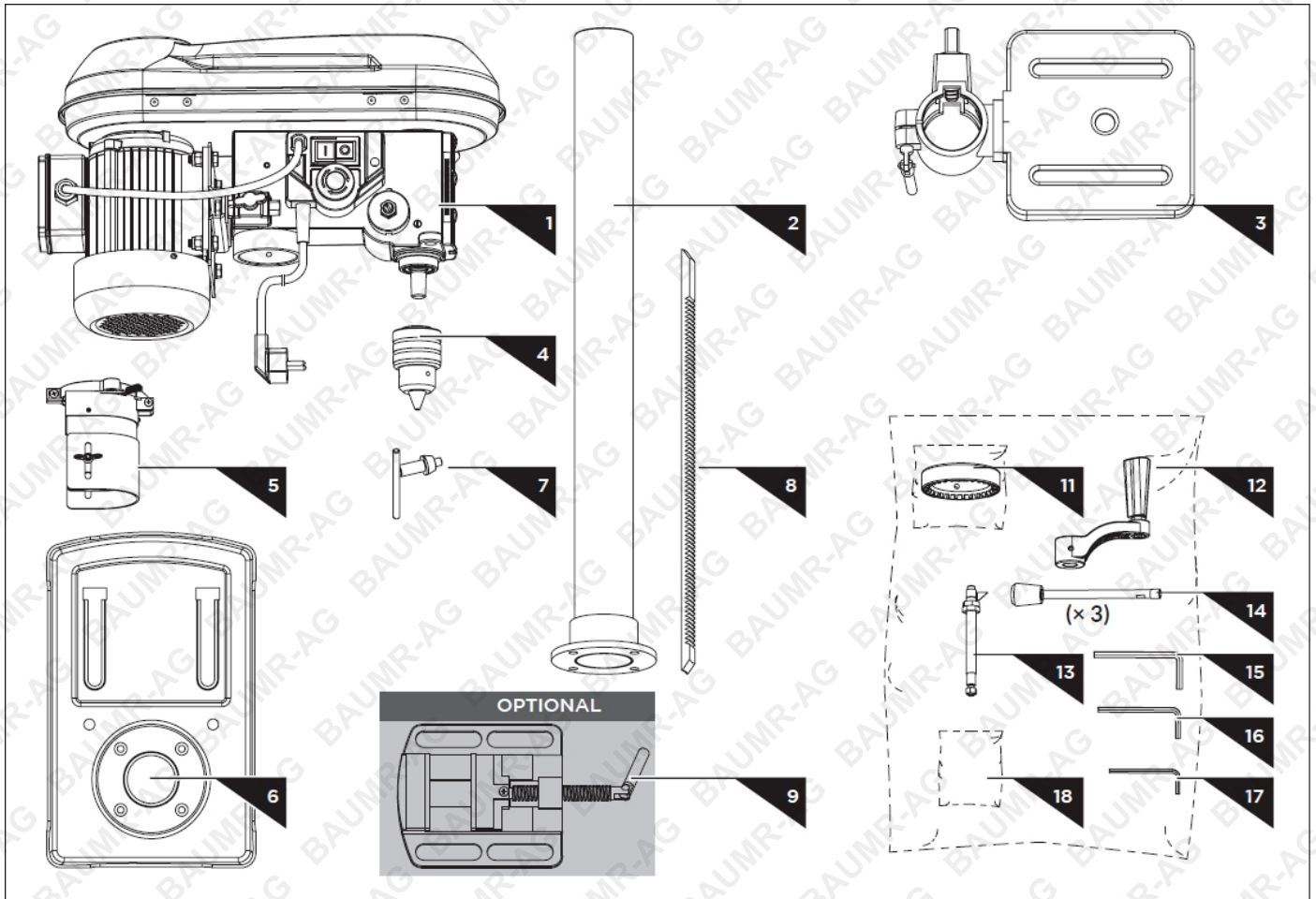

No.	Name	No.	Name
1	Machine Head	11	Collar
2	Column Tube	12	Height Crank
3	Drilling Bench	13	Depth Stop
4	Drill Chuck	14	Drill lifting arm (x3)
5	Drill Chuck Guard	15	Allen Key, 5mm
6	Baseplate	16	Allen Key, 4mm
7	Drill Chuck Key	17	Allen Key, 3mm
8	Rack	18	Hardware Bag: M8x20 (x4) Optional: M10x35 (x2)
9	Plier (Optional - Sold Separately)		

# Assembly

This drill press was partially assembled at the factory. To assemble your machine, follow the below instructions.

## Column Tube

Place the column tube on the baseplate. Bolt the column tube to the baseplate with the four screws M8×20 supplied. Tighten the screws moderately tight with an open-end wrench SW 13 (not scope of delivery) so that the threads in the baseplate do not strip.

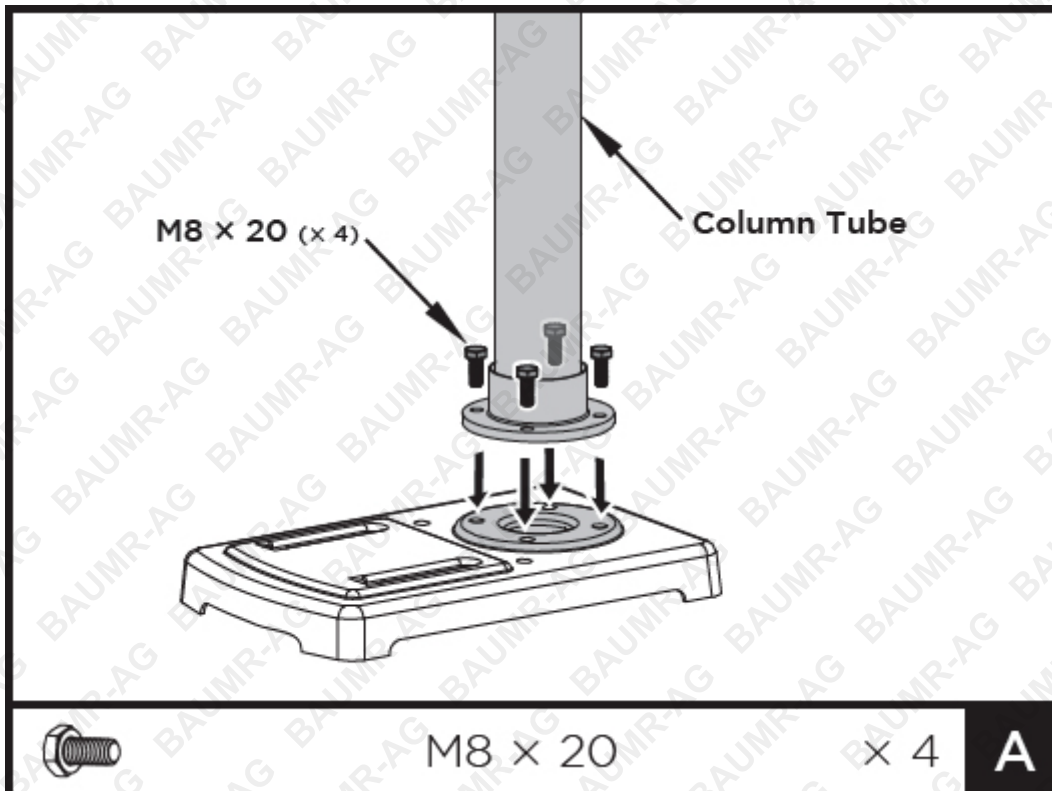

## Drilling Bench

1. Place the drilling bench holder over the rack. The teeth of rack must mesh with the teeth of gear. See below illustration 1.
2. Slide the drilling bench on the column tube. Make sure the bottom bevel of rack insert into the bottom disc of the column tube. See below illustration 2.

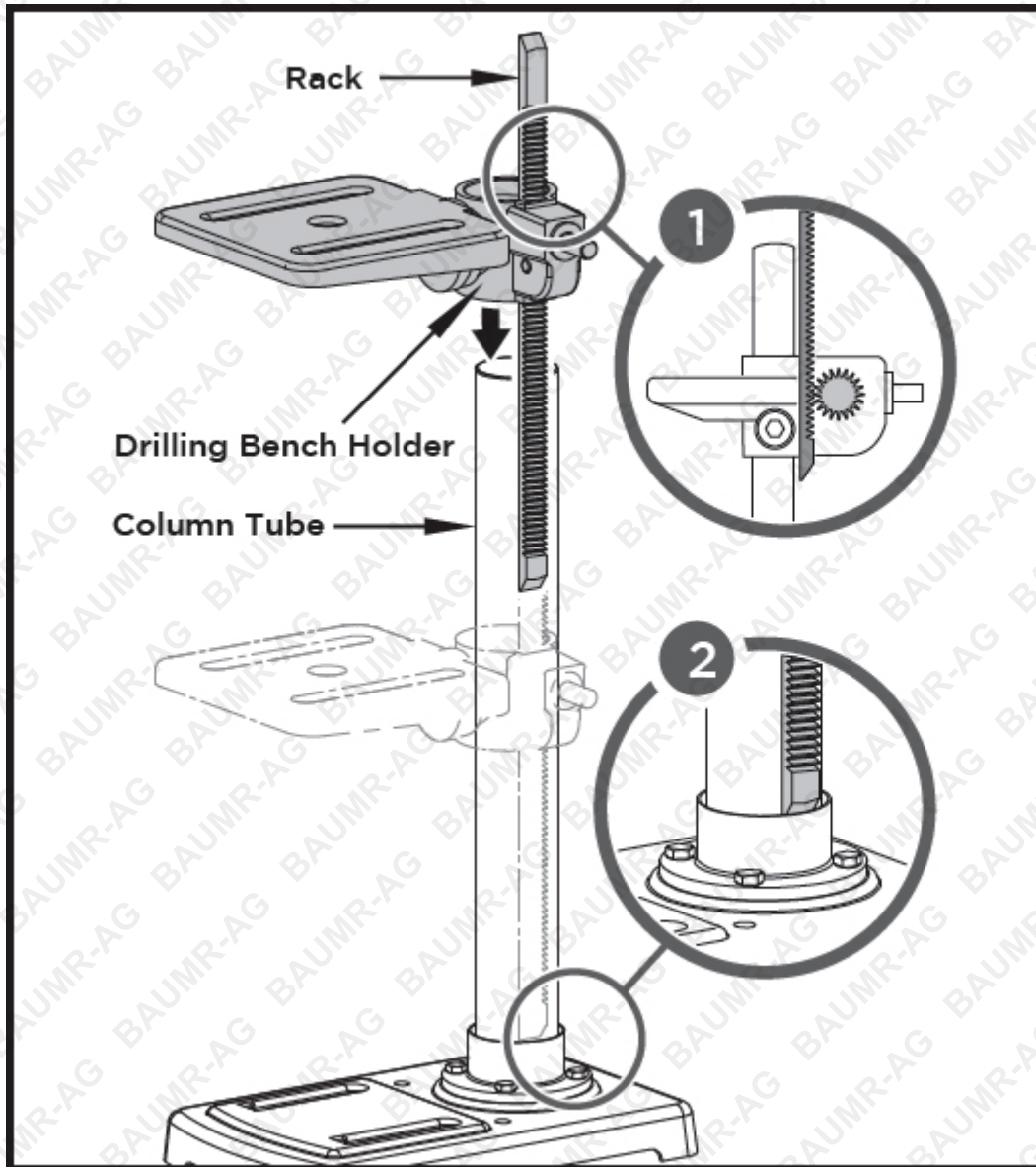

3. Slide the collar over the column tube with bevelled edge facing down until it presses against the top of the rack. See below illustration 3.
4. Tight the set screw, but do not overtighten it. See below illustration 4.

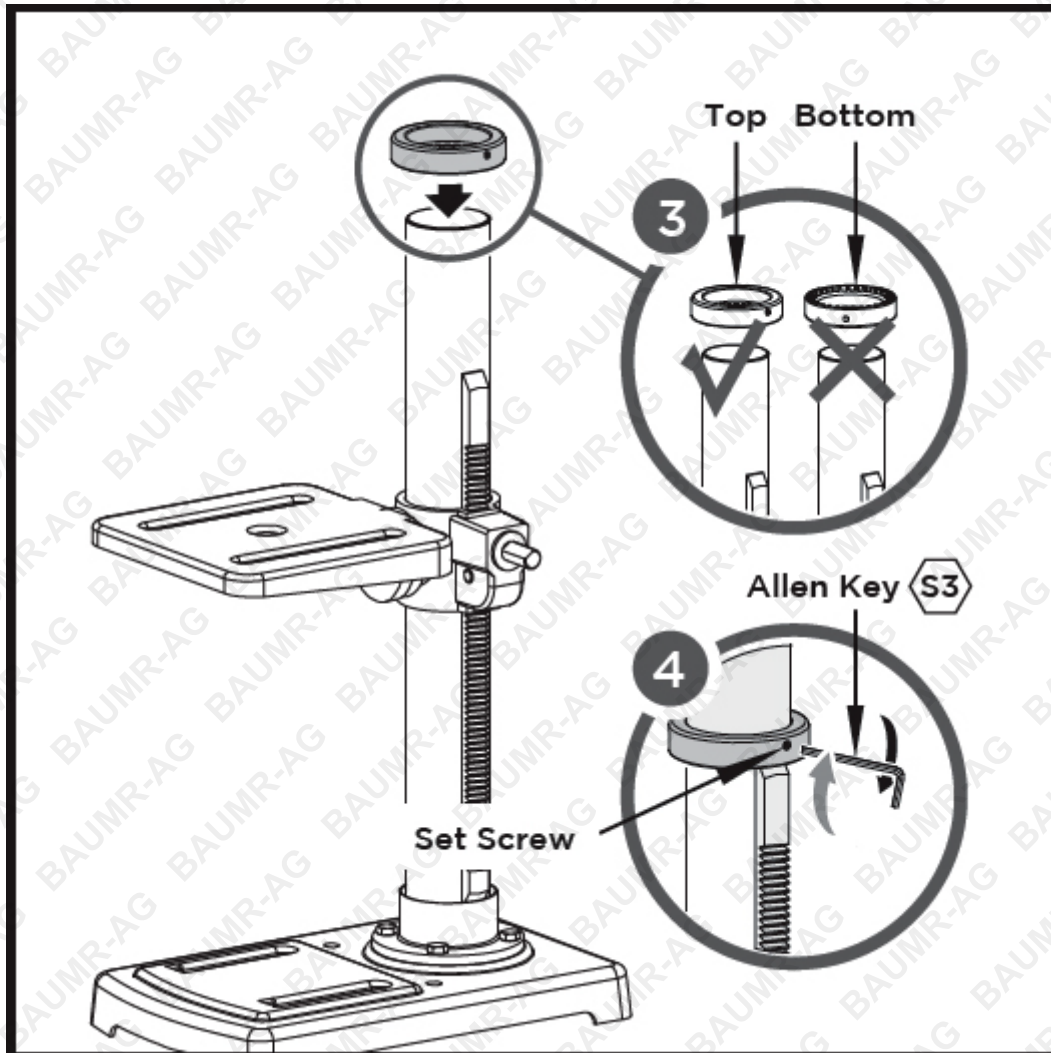

5. Slide the height crank over the shaft on the side of drilling bench. See below illustration 5.
6. Secure the height crank to the shaft using the Allen key 3mm. See below illustration 6.

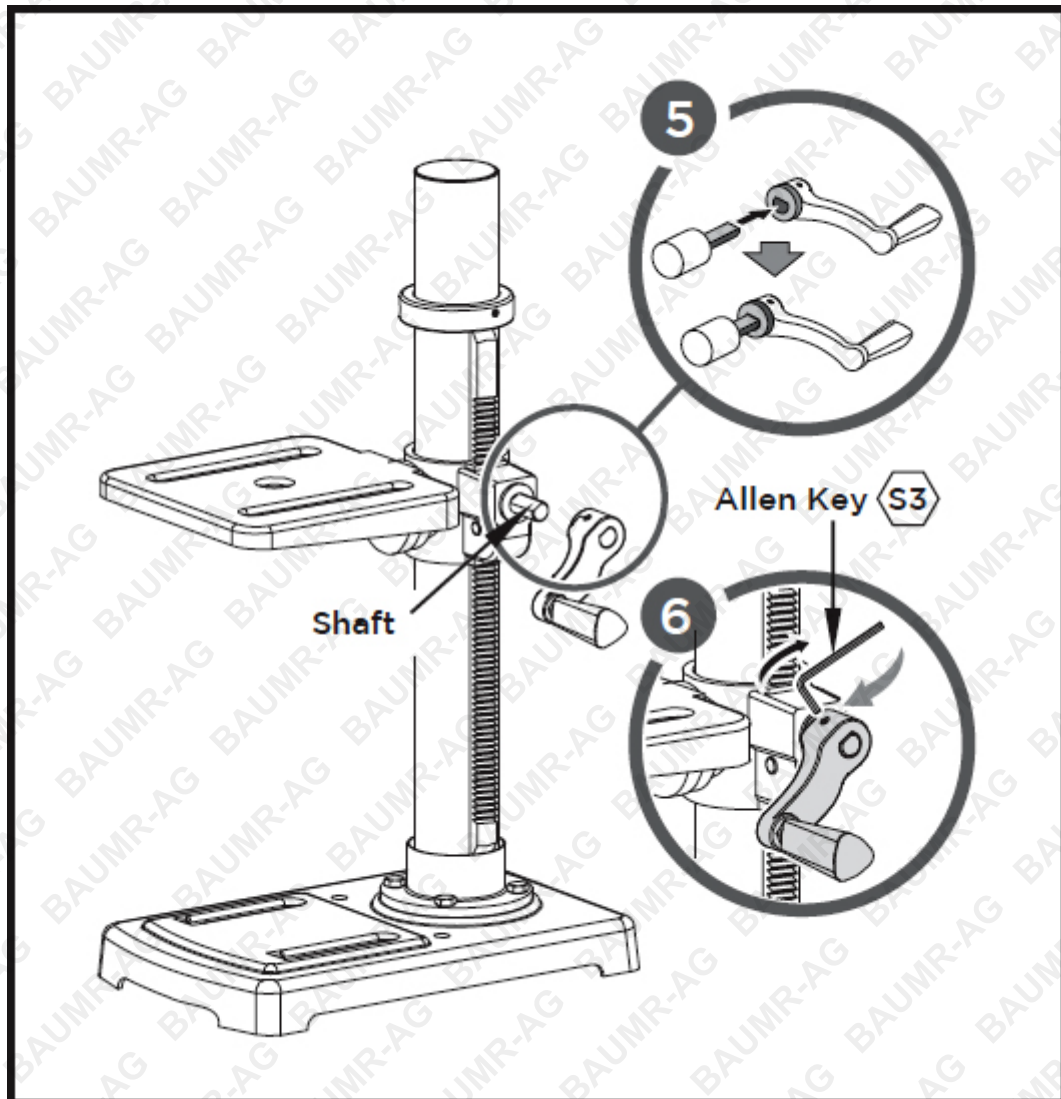

## Machine Head

Place the machine head on the column tube and secure the machine head with the two grub screws to the side with the Allen key 4mm.

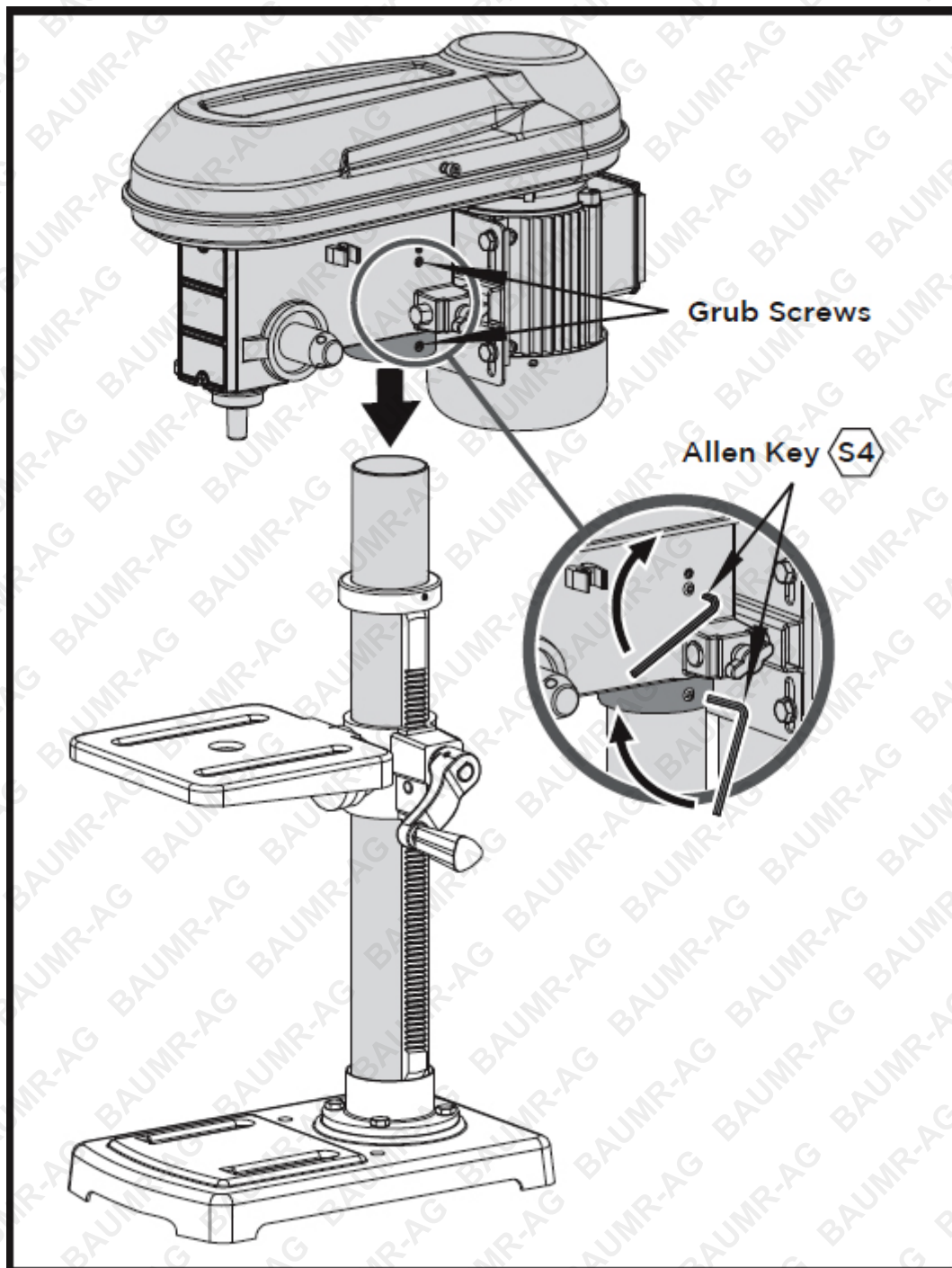

## Drill Chuck Guard

Put the drill chuck guard on the upper part of the drill spindle. Secure the drill chuck guard with a screwdriver (not scope of delivery).

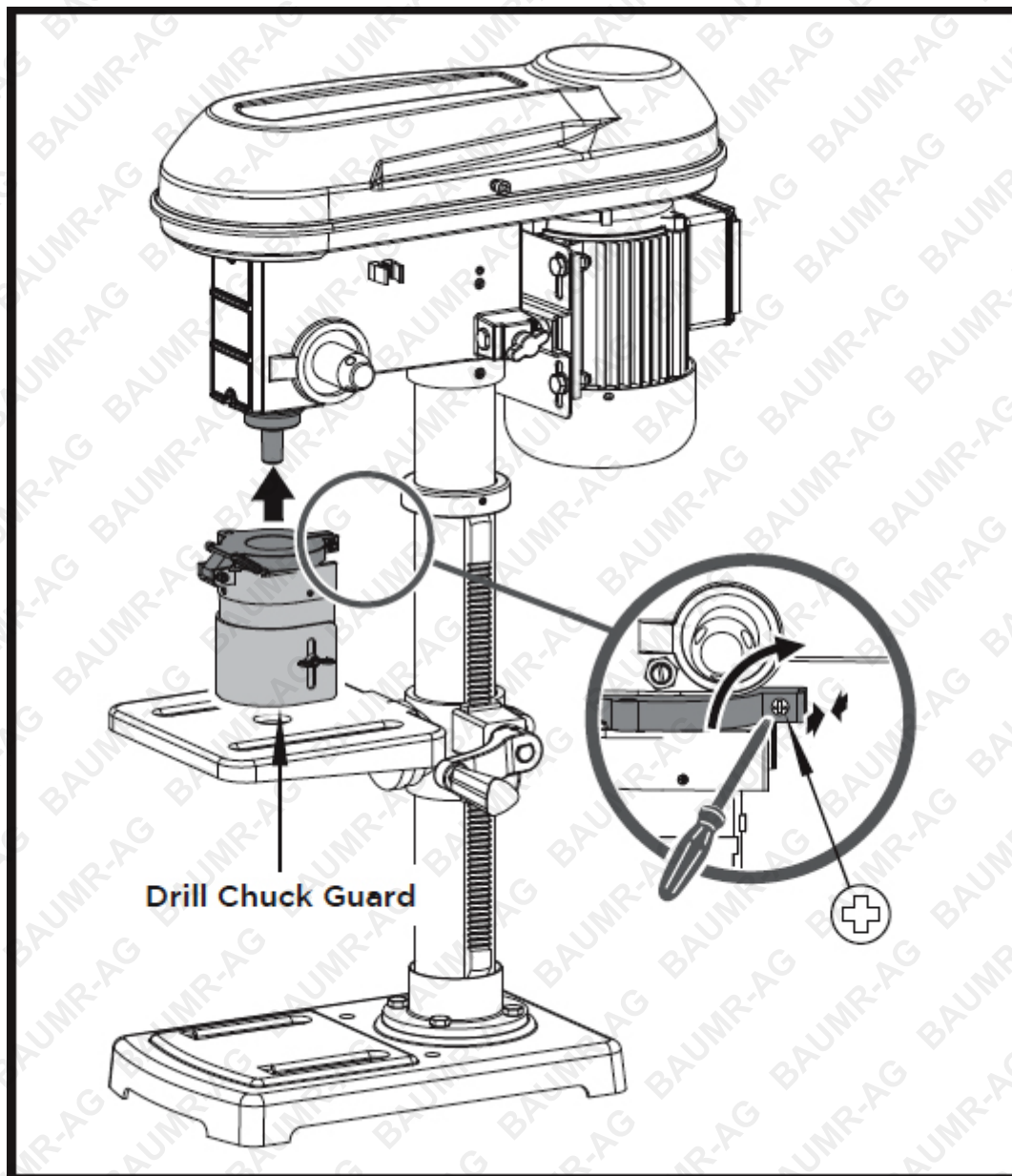

## Drill Chuck

Fold the drill chuck guard upwards. Insert the drill chuck on the taper of the drill spindle. Push the drill chuck onto the drill spindle with a few light taps. Use a plastic hammer for this purpose.

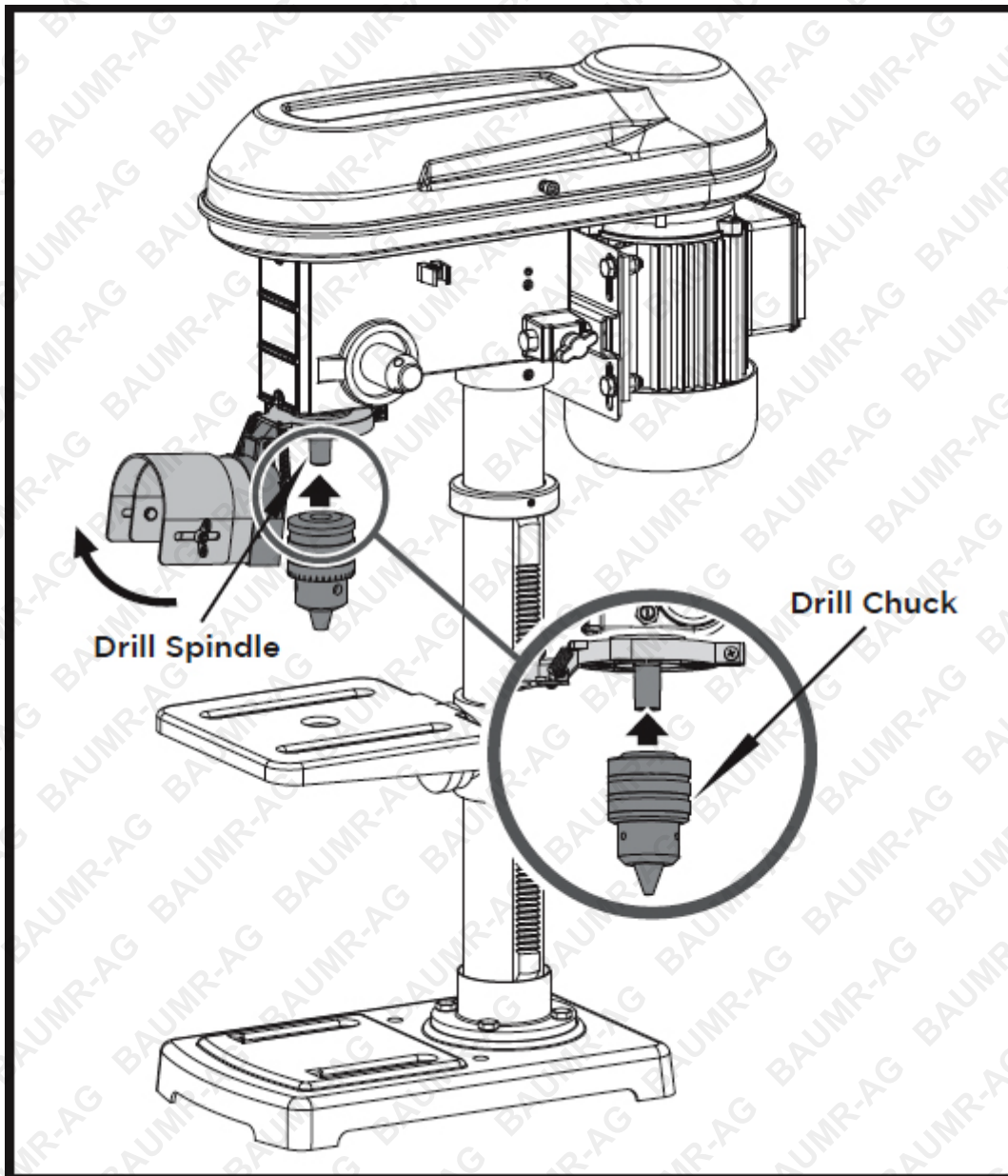



## Drill Lifting Arms

Bolt the three drill lifting arms into the hand spindle guide. Tighten the three-hole lifting arms with an open-end wrench SW 6 (not scope of delivery).

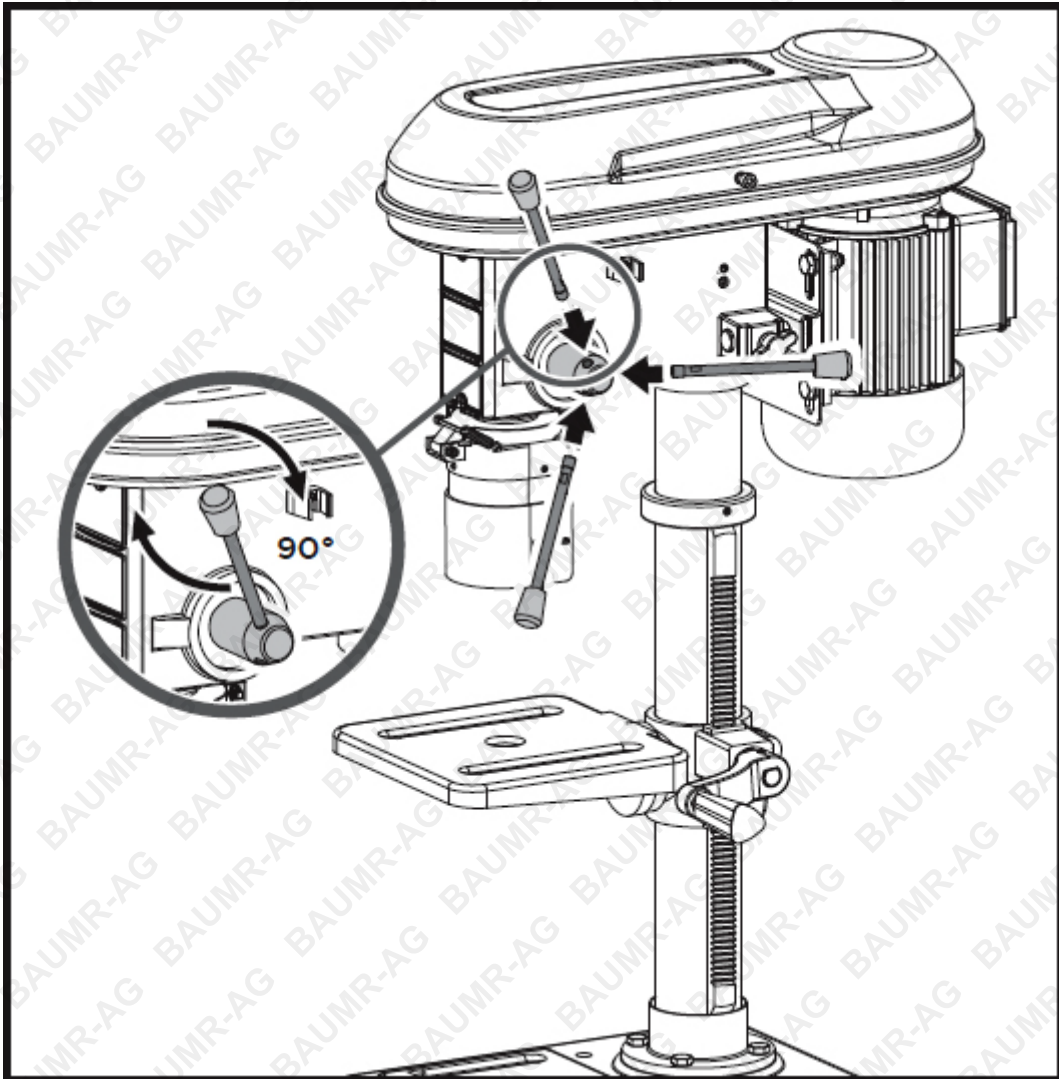

## Drill Chuck Key

Attach the drill chuck key into the key holder.

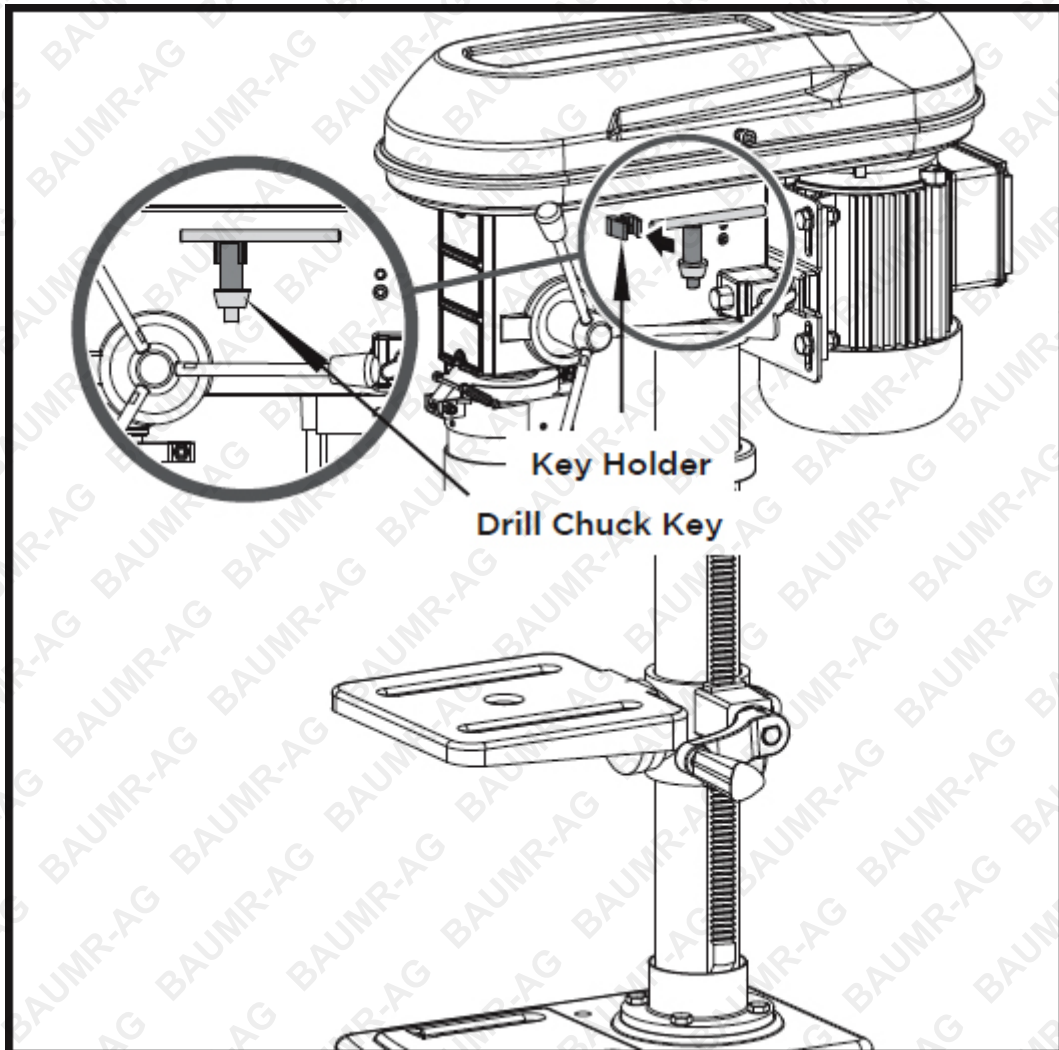

## Depth Stop

1. Remove the washer and nut from the depth stop. See below illustration 1.
2. Insert the depth stop through the hole in the fence. See below illustration 2.
3. Screw the depth stop with washer and nut that just had been removed from step 1. Centrally align the depth stop into the bore of the fence. See below illustration 3.
4. The home position of pointer should be 0mm. See below illustration 4.

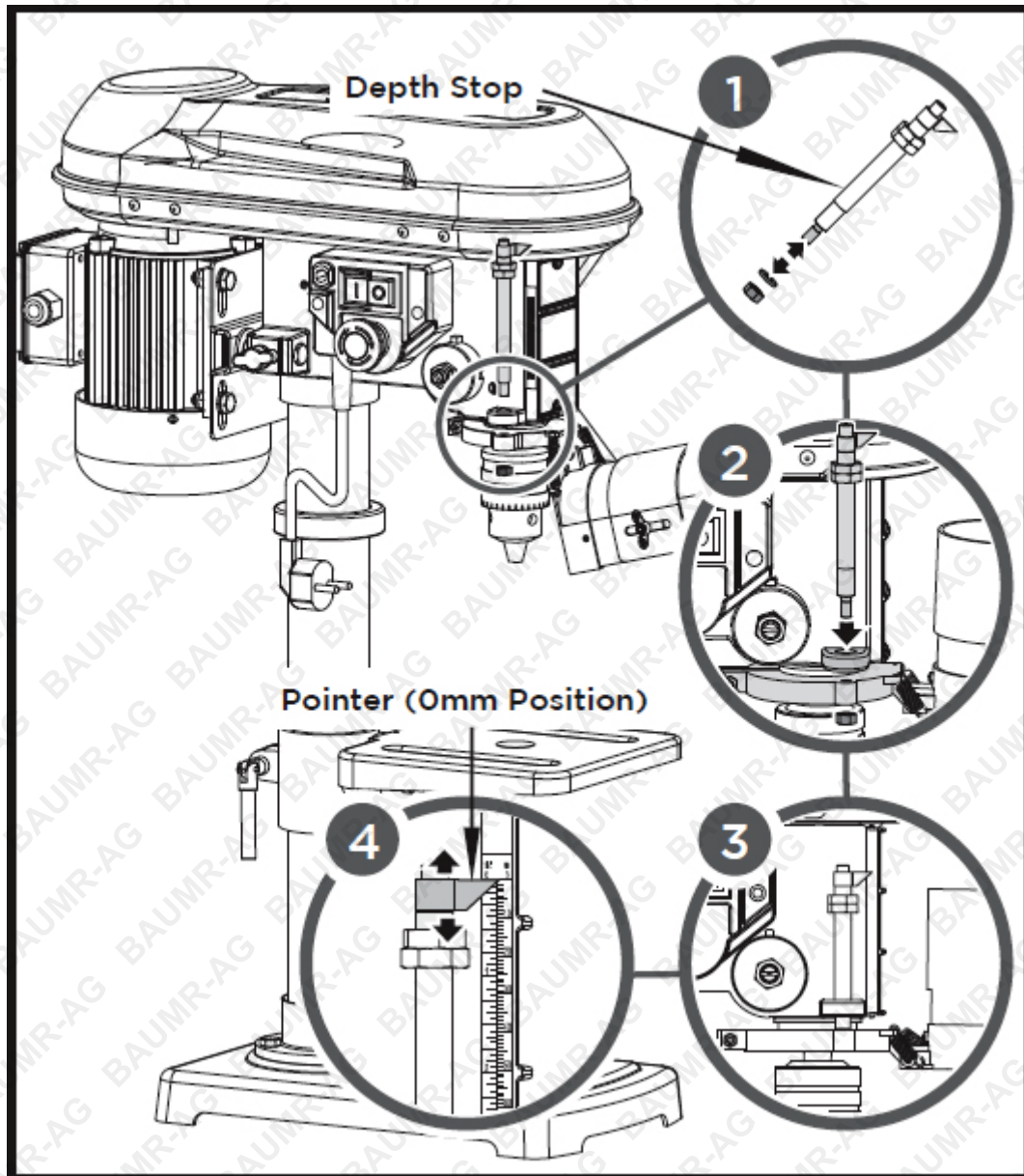

## Plier (Optional- Sold Separately)

The plier is optional, with bolts, flat washers and nuts mounted on the drilling bench or the baseplate.

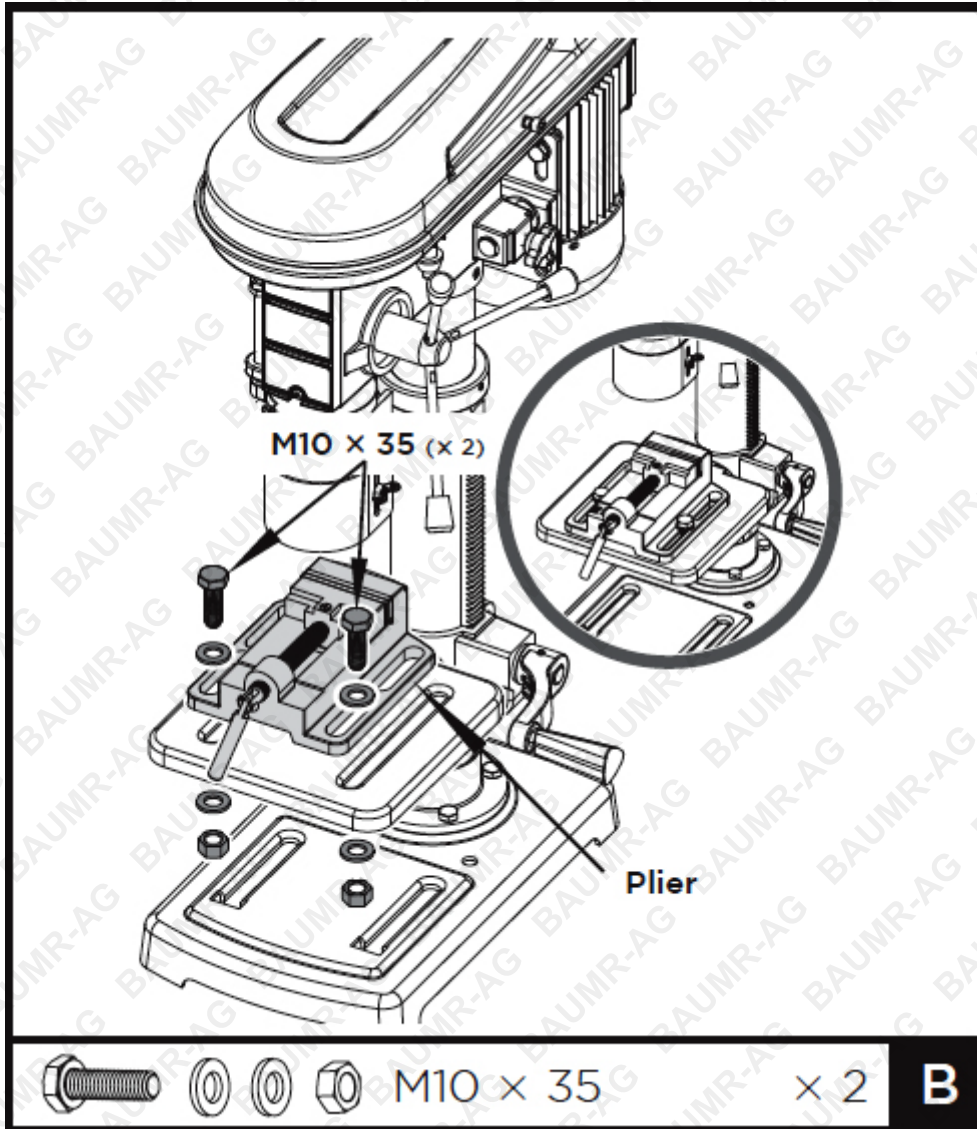

# Features and Controls

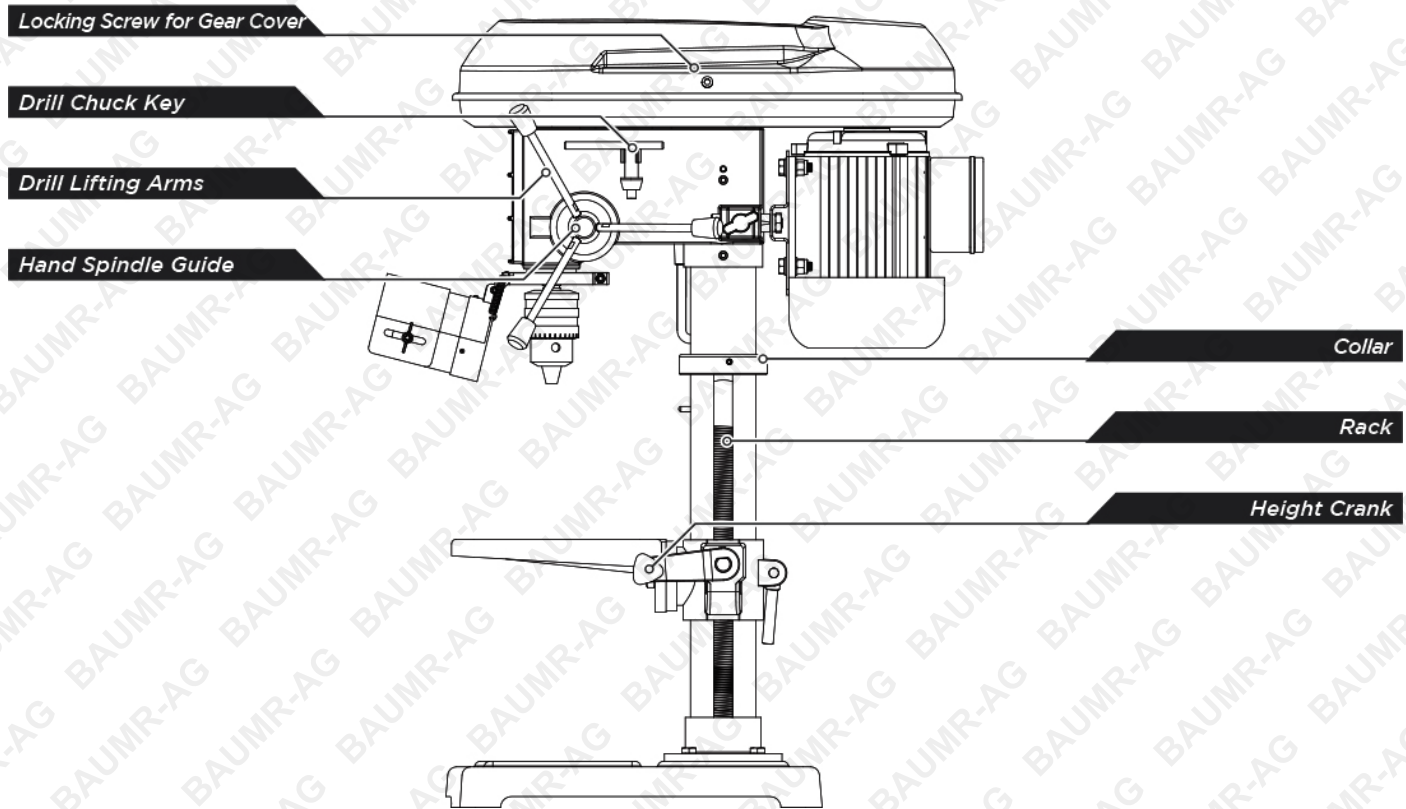
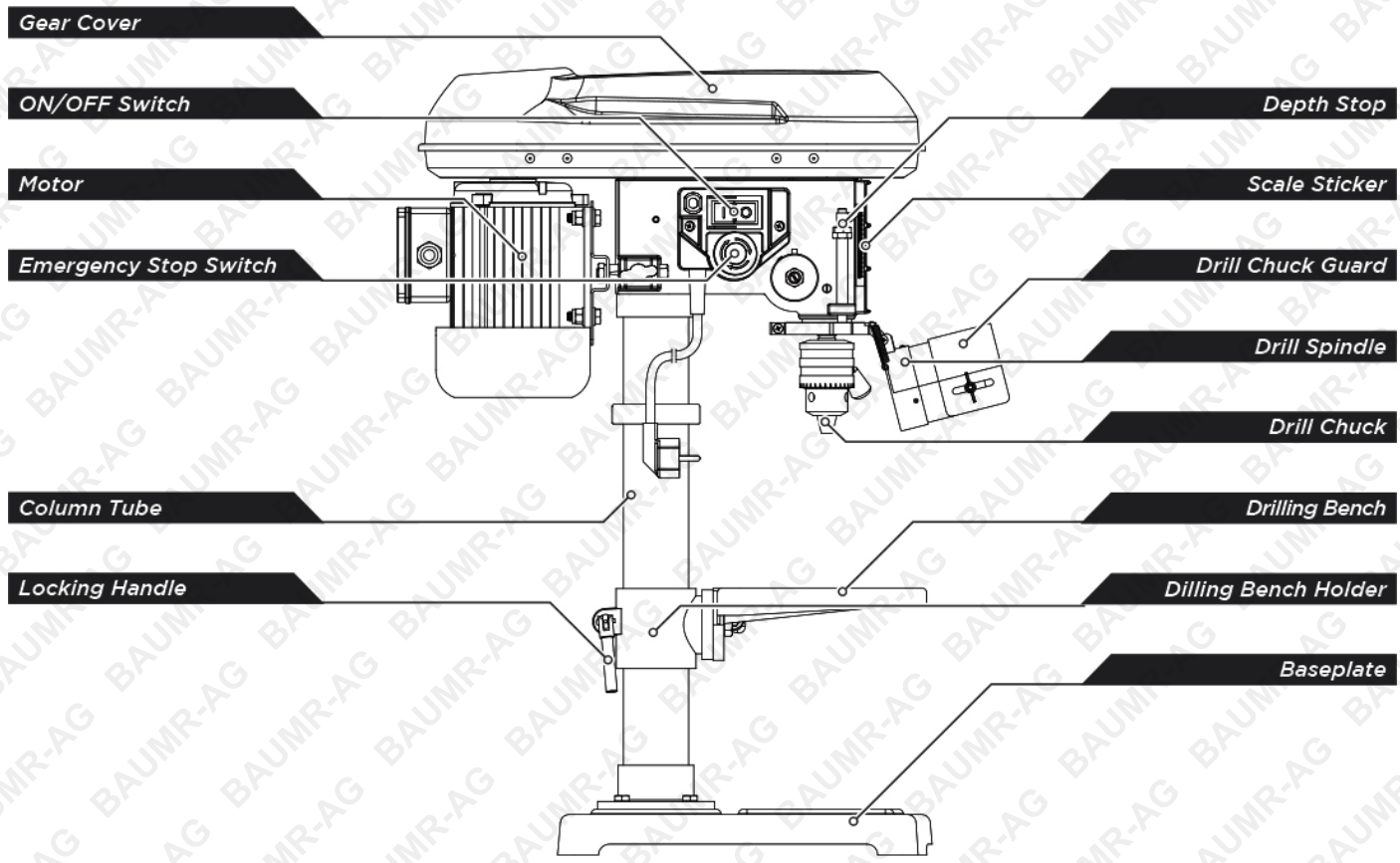

## Set-Up

Place the drill press on a solid flat surface. Ideally, bolt the drill press to the surface. Use the two holes in the baseplate for this.

### Selecting the Speed

1. Release the locking screw on the gear cover with the Allen key 5mm.
2. Pull the locking screw and open the gear cover.

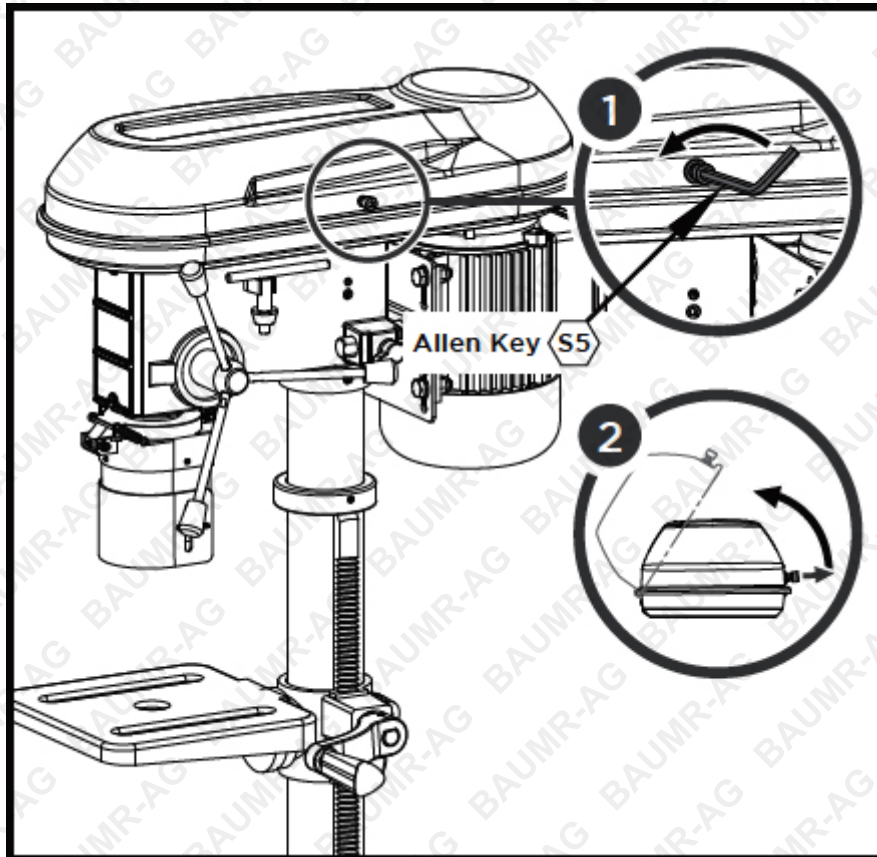







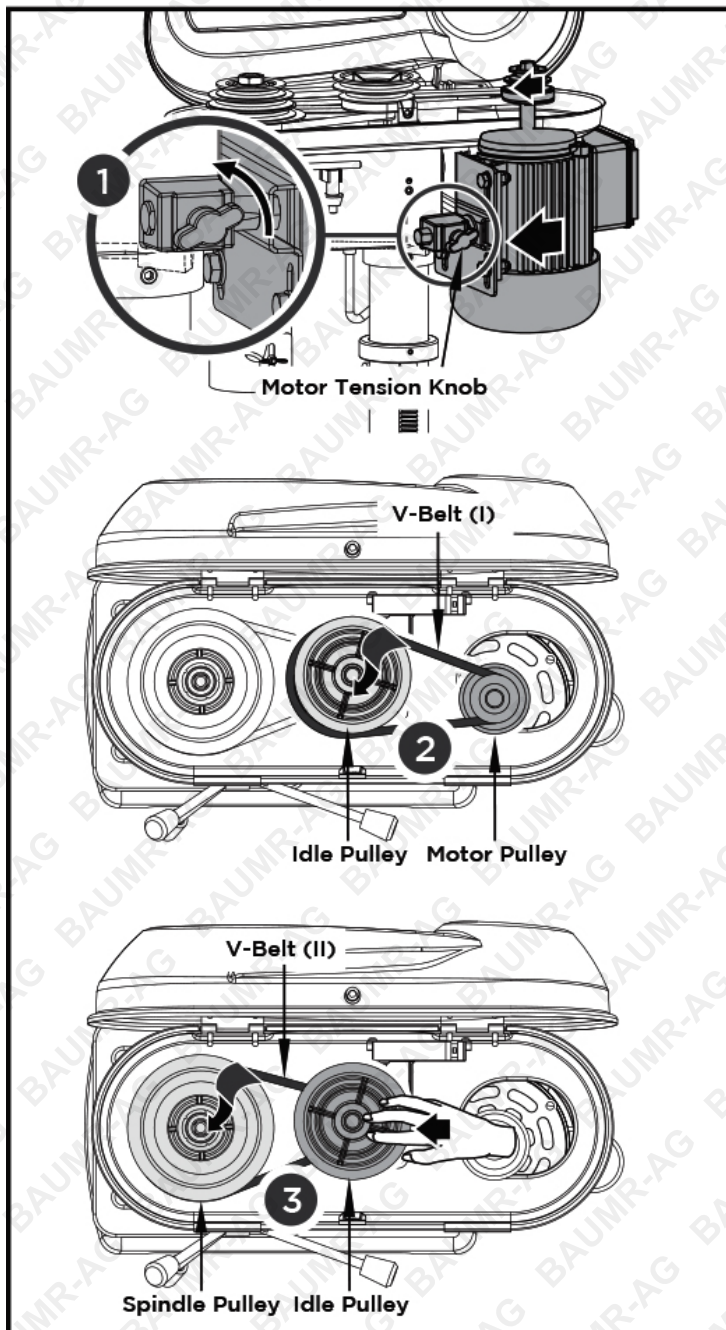
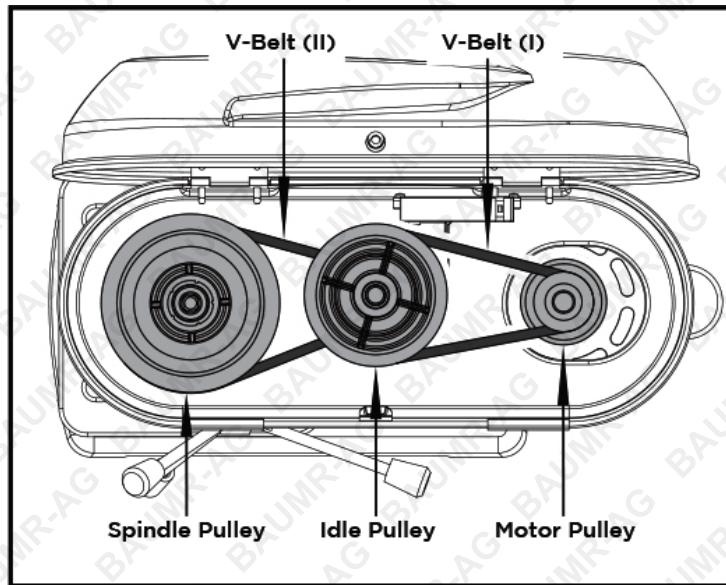

3. Loosen the motor tension knob on each side of the headstock.
4. Slide the motor forward a little to release the load on the V-belts. See below illustration 2.
5. Remove the V-belt between idle pulley and motor pulley first, then slide idle pulley towards the spindle pulley to release the load on the V-belt between idle pulley and spindle pulley. Remove the second V-belt. See below illustration 2 & 3.
6. Place the two V-belts on the desired assembly to reach the specified speed.
7. Slide the motor back to tension the V-belts again. The V-belts are correctly tensioned when it gives way slightly when pressed. Deflection distance of belt is 5-10mm.
8. Lock this position with the two motor tension knobs.
9. Close the gear cover. Fasten the locking screw on the gear cover with the Allen key 5mm.

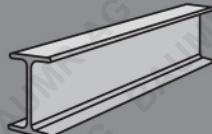
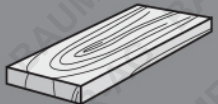
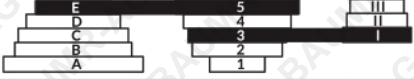
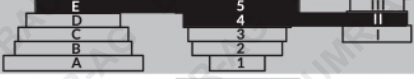
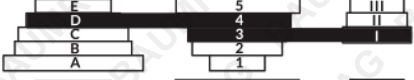
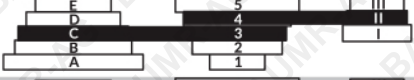

**The gear cover is equipped with a interlock switch. If the gear cover is not closed correctly, the device cannot be switched on.**

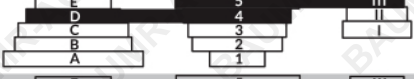

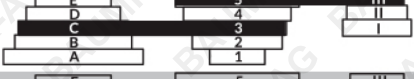
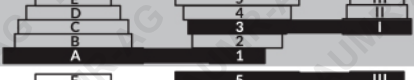
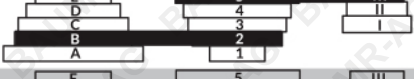
**Recommended speeds for different drill sizes and materials:**

	 Connection	 Min <sup>-1</sup>	 [ mm ]	 [ mm ]
	E-5 / 3-I	2700	< 2	< 3
	E-5 / 4-II	2200	2 - 3	3 - 4
	D-4 / 3-I	1980	3 - 4	4 - 5
	C-3 / 4-II	1400	4 - 5	5 - 6
	B-2 / 3-I	1220	5 - 6	6 - 7
	D-4 / 5-III	1100	6 - 7	7 - 8
	B-2 / 4-II	1000	7 - 8	8 - 9
	C-3 / 5-III	900	8 - 9	9 - 10
	A-1 / 3-I	770	9 - 10	10 - 11
	B-2 / 5-III	680	10 - 11	11 - 12
	A-1 / 4-II	600	11 - 12	12 - 13
	A-1 / 5-III	420	> 12	> 13

**Tensioning the V-belts**

1. Release the locking screw on the gear cover.
2. Open the gear cover.
3. Loosen the motor tension knob on each side of the headstock.
4. Slide the motor back to tension the V-belts.
5. The V-belts are correctly tensioned when it gives way lightly when pressed. Deflection distance of belt is 5-10mm.
6. Tighten the two motor tension knobs.
7. Close the gear cover. Fasten the locking screw on the gear cover with Allen key 5mm.



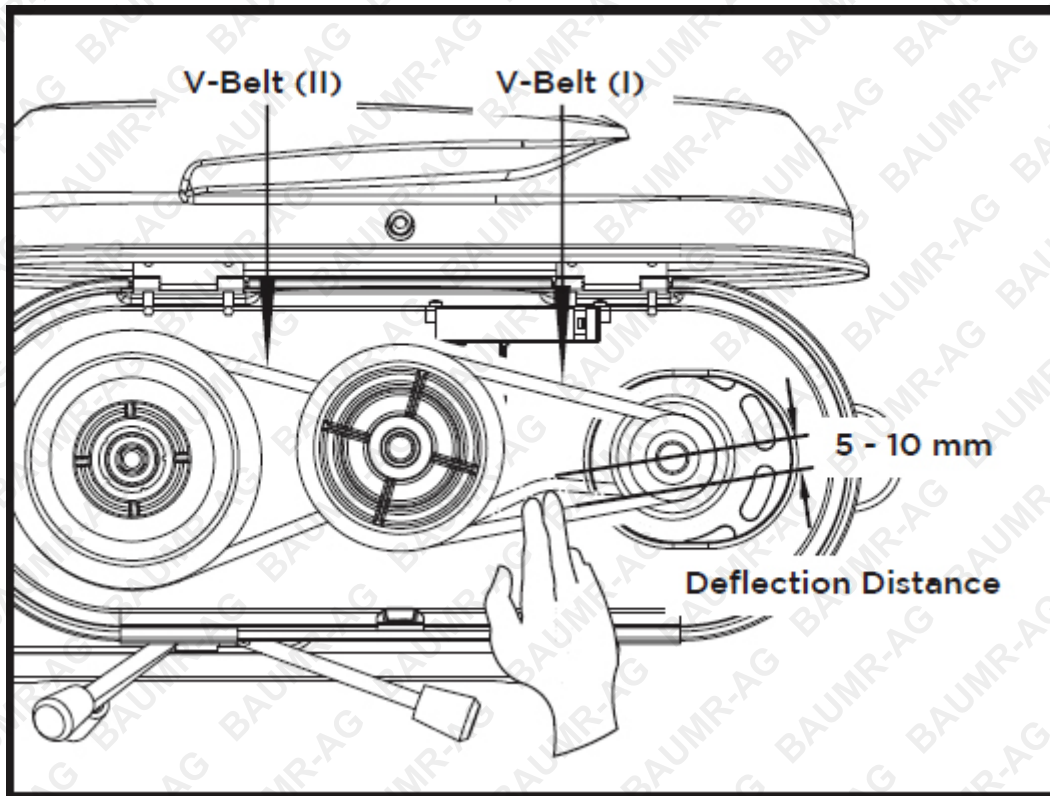

## Adjusting the Drilling Bench

1. Release the locking handle. See below illustration 1.
2. Rotate the height crank clockwise or anti-clockwise to the desired height. See below illustration 2.
3. Pivot the drilling bench to the desired position.
4. Fasten the drilling bench again with the locking handle. See below illustration 3.

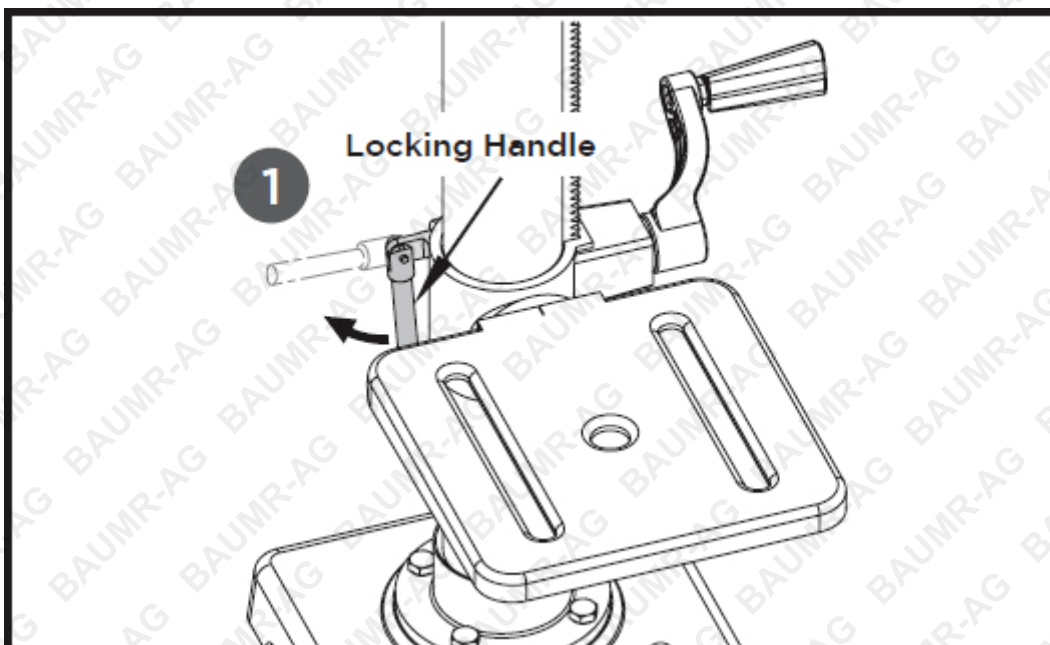

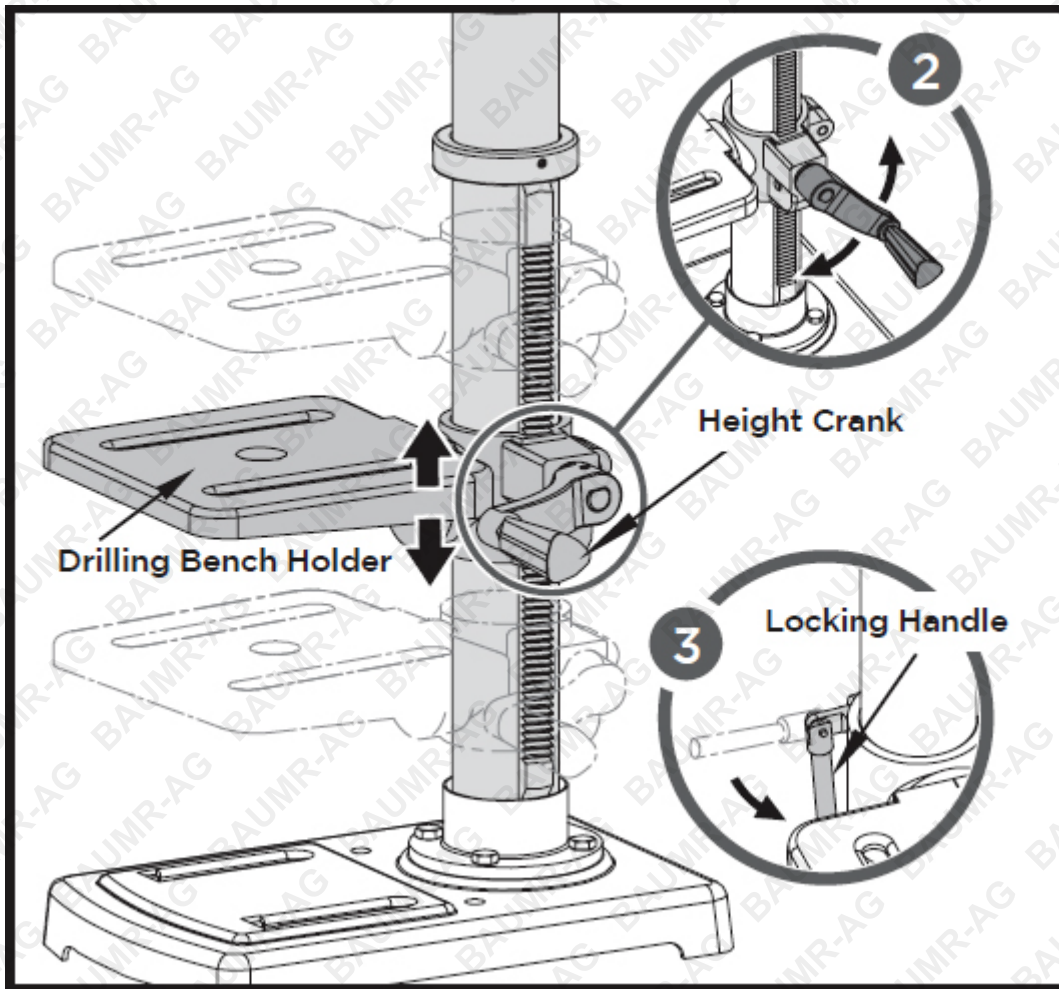

5. You can also adjust the tilt angle of the drilling bench. To do this, release the retaining screw under the drilling bench with an open-end wrench SW 19 (not scope of delivery). Tilt the drilling bench as desired to the right or left up to a max. of 45° and secure the drilling bench again with the retaining screw.

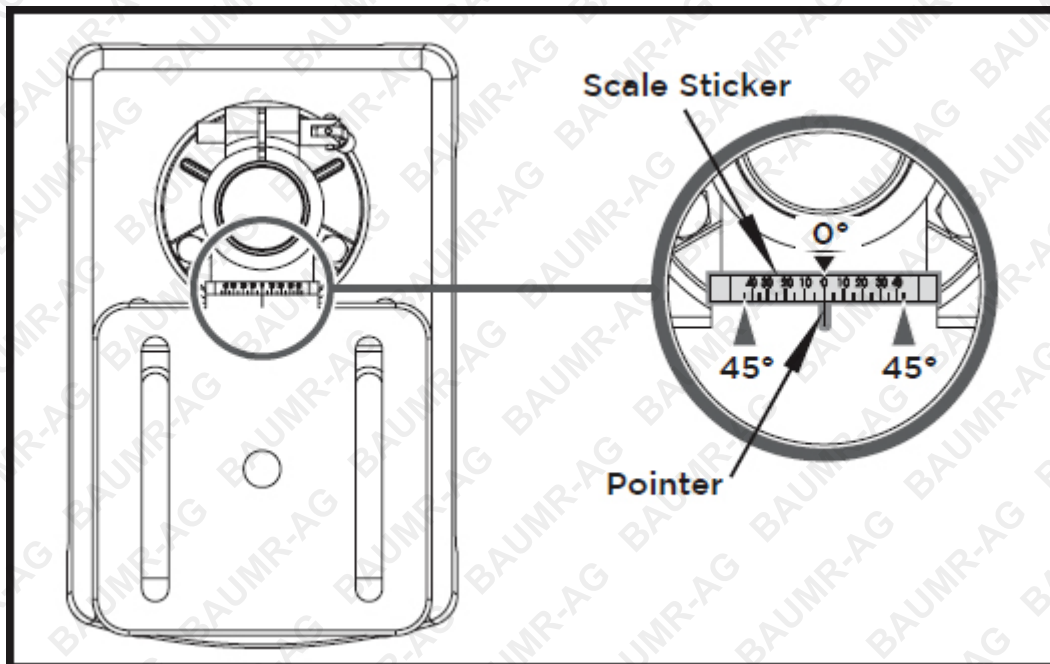
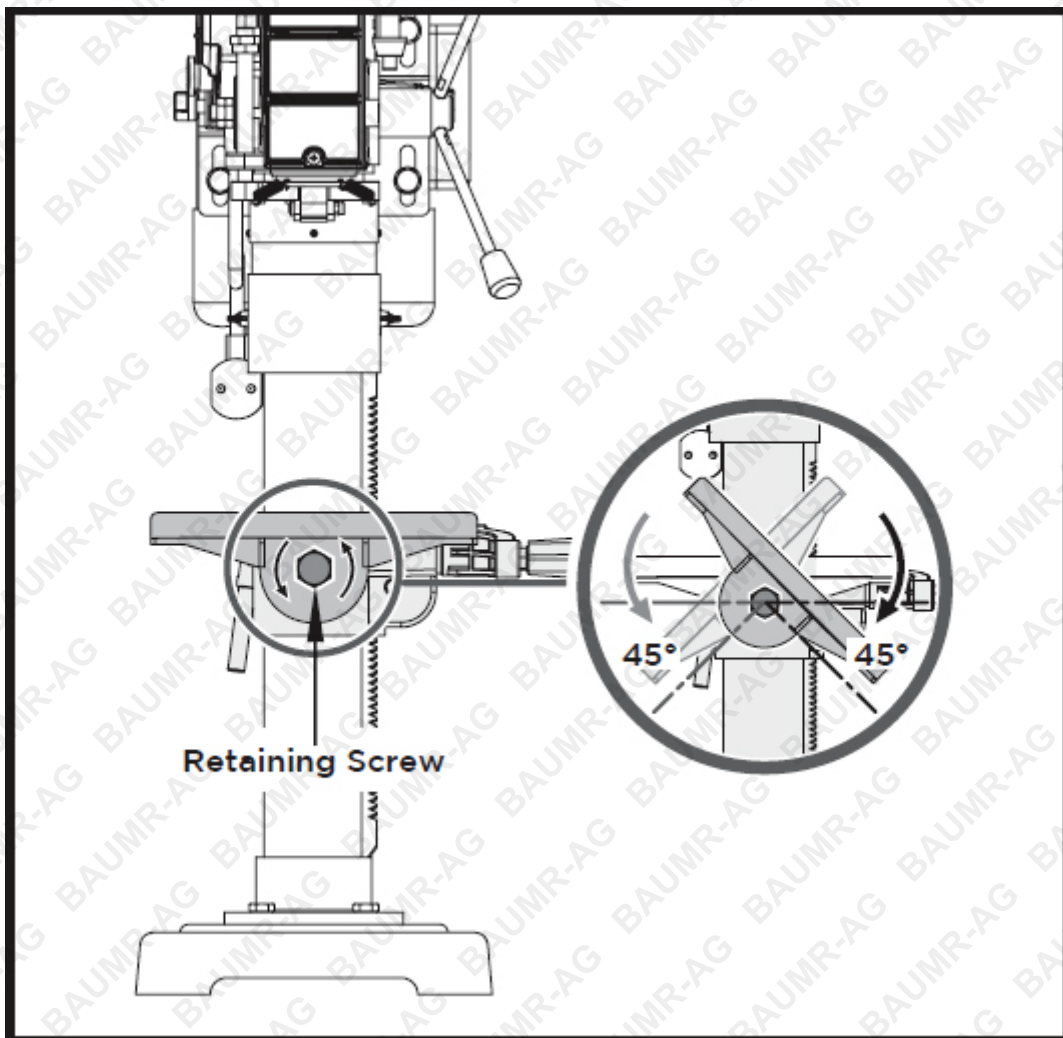

## Changing the Drill Bit

Remove the plug from the mains socket before changing the bit. This will prevent an accidental start-up.

1. Fold the drill chuck guard up.
2. Release the retaining jaws of the drill chuck with the drill chuck key.
3. Remove the bit.
4. Insert a new bit.
5. Tighten the retaining jaws of the drill chuck with the drill chuck key.
6. Check that the bit is centred.
7. Fold the drill chuck guard down again.
8. Attach the drill chuck key back to the key holder.



**Under no circumstances must you leave the drill chuck key inserted.**

## Operation



Always place a piece of backup material (wood, plywood, etc.) on the table underneath the workpiece. This will prevent splintering on the underside of the workpiece as the drill bit breaks through. To keep the material from spinning out of control, it must contact the left side of the column, or be clamped (not included) to the table.

For small workpieces that cannot be clamped to the table, use a drill press vise (not included). The vise must be clamped or bolted to the table to avoid injury.

## Drilling

1. Starting the drill press.
  - The drill press can be switched on by pressing the green ON switch "I".
  - The red OFF switch "0" has to be pressed to switch off the drill press.
2. Turn one of the drill lifting arms anti-clockwise.
3. The drill chuck is lowered.
4. Drill into the workpiece at the appropriate feed rate and to the desired depth.
5. Be aware of any necessary chip breaking on the way to the desired depth.
6. Move the bit slowly back to the stop position.

## General Drilling Guidelines - Drilling A Hole



**WARNING!** To prevent the workpiece and the backup material from slipping from your hand while drilling, position the workpiece and backup material to the left side of the column. If the workpiece and the backup material are not long enough to reach the column, clamp the workpiece and backup material to the table. Failure to do this could result in personal injury.

1. Mark where you want to drill the workpiece by using a center punch or a sharp nail.
2. Before turning the drill press ON, turn the drilling lifting arms to bring the drill bit down. Line the drill bit tip up with the mark. Clamp the workpiece in place.
3. Turn ON the drill press and pull down on the drilling lifting arms with the appropriate force needed to allow the drill bit to drill the material.



**NOTE:** Feeding too slowly might cause the drill bit to turn in the chuck. Feeding too rapidly might stop the motor, cause the belt to slip, force the workpiece loose, or break the drill bit. Practice with scrap material to get the feel of the machine before attempting to do any drilling operation.

## Drilling Metal

- Use metal-piercing twist drill bits.
- It is always necessary to lubricate the tip of the drill with oil to prevent overheating of the drill bit.
- All metal workpieces should be clamped down securely. Any tilting, twisting, or shifting causes a rough drill hole, and increases the potential of drill bit breakage.
- Never hold a metal workpiece with your bare hands. The cutting edge of the drill bit may seize the workpiece and throw it, causing serious injury. The drill bit will break if the metal piece suddenly hits the column.

- If the metal is flat, clamp a piece of wood under it to prevent turning. If it cannot be laid flat on the table, then it should be blocked and clamped.

## Drilling Wood

- Brad point bits are preferred. Metal piercing twist bits may be used on wood.
- Do not use auger bits. Auger bits turn so rapidly that they can lift the workpiece off of the table and whirl it around.
- Always protect the drill bit by positioning the table so that the drill bit will enter the center hole when drilling through the workpiece.
- To prevent splintering, feed the drill bit slowly right as the bit is about to cut through to the backside of the workpiece.
- To reduce splintering and protect the point of the bit, use scrap wood as a backing or a base block under the workpiece.

## Emergency Stop Switch



**WARNING!** When encountering incidental situation, such as, hand getting drilled, hair getting caught, sudden failure of machine or other situations where you need to stop the operation in an emergency, please press the emergency stop switch immediately, the machine will automatically cut-out to protect the operator.

Unplug the power cord before other operations. After the danger is dismissed, turn the emergency stop switch by direction of arrows (clockwise) until it pops out (reset). The machine is in an open circuit state now, plug the power cord and operate normally.

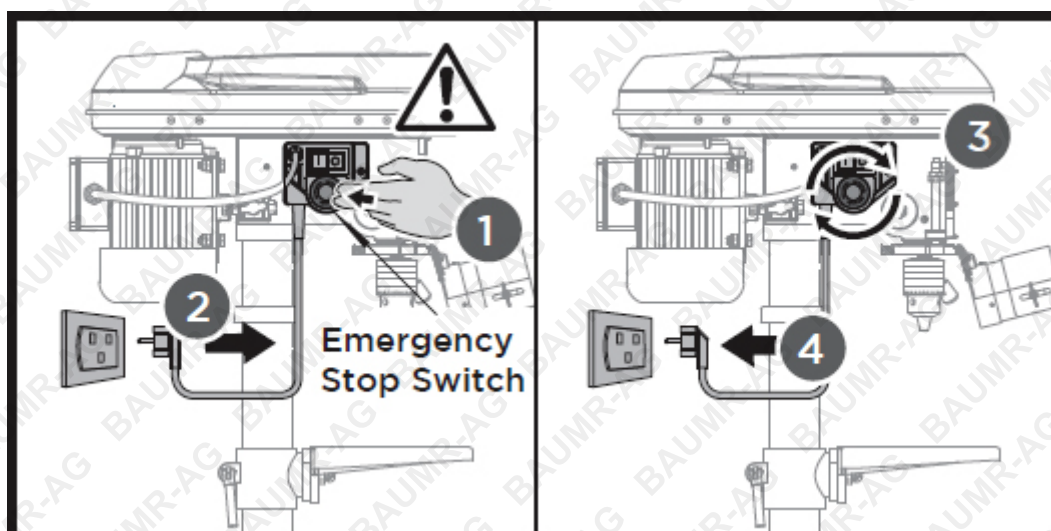

# Maintenance



**WARNING!** For your safety, turn the switch off and remove the plug from the power supply. Wait until the rotating tool stands still. All protection and safety devices must be immediately re-installed once the repair and maintenance work is completed.

**CAUTION!** All servicing of the drill press should be performed by a qualified service technician.

## Servicing

- Pull the mains plug before any adjustments, maintenance, or repair.
- Have any work on the device that is not described in this instruction guide performed by a professional. Only use original parts. Allow the device to cool off before any maintenance or cleaning is undertaken.
- There is a risk of burning!
- Always check the device before using it for obvious defects such as loose, worn or damaged parts, correct the positioning of screws or other parts. Exchange the damaged parts.
- The ball bearings in the spindle and the V-belt pulley assembly are greased and permanently sealed. Pull the spindle down and oil the spindle sleeve moderately every three months.
- Lubricate the table bracket and locking knobs if they become difficult to use.

## Cleaning

- Do not use any cleaning agents or solvents. Chemical substances can etch the plastic parts of the device. Never clean the device under running water.
- Thoroughly clean the device after every use.
- Clean the ventilation openings and the surface of the device with a soft brush or cloth.
- Remove chips, dust, and dirt with a vacuum cleaner if necessary.
- Lubricate moving parts regularly.
- Vacuum sawdust or metal shavings that accumulate in and on the motor, pulley housing, table, and work surface.
- Apply a light coat of paste wax to the column and table to help keep these surfaces clean and rust-free.
- Do not allow lubricants to come into contact with switches, V-belts, pulleys and drill lifting arms.

# Transportation and Storage

## Transportation

- Unplug the machine from the mains during transport.
- The machine must only be lifted and transported on its belt housing. Never lift the machine at the safety devices, the adjusting levers, or the drill chuck.

## Storage



**DANGER!** Store the drill press a way it cannot be started by unauthorised persons and that nobody can get injured.

**CAUTION!** Do not store the drill press unprotected outdoors or in a moist environment.

- Store the device and its accessories in a dark, dry, and frost-proof place that is inaccessible to children. The optimum storage temperature is between 5 and 30°C.
- Store the electrical tool in its original packaging.
- Cover the electrical tool to protect it from dust and moisture.



# Troubleshooting

Problem	Cause	Remedy
<b>Device doesn't start.</b>	No mains voltage. Main circuit breaker is tripped.	Check the socket, mains supply cable, cord, mains plug; if necessary, have them repaired the main fuse.
	ON switch (green) / OFF Switch (red) (1) is broken.	Take to a qualified service centre or technician
	Motor is faulty	Take to a qualified service centre or technician
<b>No Motor output turns off automatically</b>	Motor not fixed in place.	Check the tension of the V-belts and tighten the clamping screw.
	Bit not centrally clamped.	Check the bit in the drill chuck.
	Incorrect belt tension	Adjust the belt tension
<b>Loud squeaking noise.</b>	Dry spindle	Lubricate the spindle
	Loosed spindle pulley	Tighten the retaining nut on the pulley insert
	Loosed motor pulley	Tighten the set screw on the side of the motor pulley
<b>The drill bit burns or smokes</b>	Drilling at the incorrect speed	Change the speed
	The wood chips are not coming out of the hole	Retract the drill bit frequently to clear the chips
	Dull drill bit	Resharpener or replace the drill bit
	Feeding the workpiece too slowly	Feed fast enough to cut the workpiece
	Not lubricated	Lubricate the drill bit with cutting oil
<b>Excessive drill run out or wobble; drilled hole is not round</b>	Bent drill bit	Replace the drill bit
	Bit improperly installed in the chuck	Reinstall the bit.
	Worn spindle bearings	Replace the bearing. Take the press to a qualified service technician
	Lengths of cutting flutes or angles not appropriate for the hardness of the wood grain	Resharpener the drill bit correctly or replace with the appropriate type.
	Chuck not properly installed	Reinstall the chuck.
<b>Drill bit binds in the workpiece</b>	The workpiece is pinching the bit	Support or clamp the workpiece.
	Excessive feed pressure	Feed more slowly.
<b>Spindle returns too slowly or too quickly</b>	Coil spring has improper tension	Adjust the coil spring tension
<b>Chuck falls off spindle</b>	Dirt, grease, or oil on the tapered surface on the spindle or in the chuck	Clean the tapered surface of both the chuck and spindle with a household detergent.

Problem	Cause	Remedy
<b>Motor will not run</b>	Defective or broken switch	Take to a qualified service centre or technician
	Defective or damaged power cord	Take to a qualified service centre or technician
	Open circuit, loose connections, or burned-out motor	Take to a qualified service centre or technician
	Low voltage	Check the power line for the proper voltage. Use another circuit or have a qualified technician check on it.
<b>Motor stalls</b>	Short circuit in motor	Take to a qualified service technician
	Incorrect fuses or circuit breakers	Replace with correct fuse or circuit breaker for the circuit
	Overloaded circuit	Turn off other machines and retry
	Low Voltage	Check the power line for the proper voltage. Use another circuit or have a qualified electrician upgrade the service.

# Specifications

<b>Motor</b>	600W Brushless
<b>Chuck</b>	16mm Stainless Steel
<b>Number of Speeds</b>	12
<b>Variable Speeds (rpm)</b>	420 / 600 / 680 / 770 / 900 / 1000 / 1100 / 1220 / 1400 / 1980 / 2200 / 2700
<b>Drill Travel</b>	60mm
<b>Swing</b>	252mm/10"
<b>Spindle Feed</b>	Rack and Pinion
<b>Spindle to Table</b>	410mm
<b>Spindle to Base</b>	525mm
<b>Table diameter</b>	195mm
<b>Table Tilt</b>	±45°
<b>Switches</b>	Dust Protected NVR

*Note: Minimal Assembly required*



**Some experts believe that the incorrect or prolonged use of almost any product may cause serious injury or death. To help reduce your risk of serious injury or death, refer to the information below. For more information, see [www.datastreamserver.com/safety](http://www.datastreamserver.com/safety)**

- Consult all documentation, packaging, and product labelling before use. Note that some products feature documentation available online. It is recommended to print and retain the documentation.
- Before each use, check the product for loose/broken/damaged/missing parts, wear, or leaks (if applicable). Never use a product with loose/broken/damaged/missing parts, wear, or leaks.
- Products must be inspected and serviced (if applicable) by a qualified technician every 6 months. This is based on average residential use by persons of average size and strength, and on a property of average metropolitan size. Use beyond these recommendations may require more frequent inspections/servicing.
- Ensure that all users of the product have completed a suitable industry recognised training course before being allowed access to the product.
- The product has been supplied by a general merchandise retailer that may not be familiar with your specific application or description of application. Be sure to attain third-party approval from a qualified specialist for your application before use, regardless of any assurances from the retailer or its representatives.
- This product is not intended for use where fail-safe operation is required. As with any product (for example, automobile, computer, toaster), there is the possibility of technical issues that may require the repair or replacement of parts, or the product itself. If the possibility of such failure and the associated time it may take to rectify could in any way inconvenience the user, business, or employee, or financially affect the user, business, or employee, then the product is not suitable for your requirements. This product is not intended for use where incorrect operation or a failure of any kind, including but not limited to, a condition requiring product return, replacement, parts replacement, or service by a technician may cause financial loss, loss of employee time or an inconvenience requiring compensation.
- If this product has been purchased in error when considering the information presented here, contact the retailer directly for details of their returns policy, if required.

**Bäumr-AG**<sup>®</sup>  
.com.au

©2022 Baumr-AG. All rights reserved. No part of this document, including descriptive content, concepts, ideas, diagrams, or images may be reproduced or transmitted in any form or by any means, electronic or mechanical, including photocopying, scanning, or recording, or any information storage and retrieval system, without express permission or consent from the publisher.