

i30

Body Composition Analyzer

USER MANUAL



About this manual

This manual explains how to install and use I30. Please refer to WARNING and CAUTION signs where users need to be extra careful while using I30. Before using the product, users should carefully read this manual including precautions.

Trademark

The name of the product in this manual may be the trademark or the registered mark of the company.



If there is any problem with I30 or you have clinical questions, contact us.

 Manufacturer Mediana Co., Ltd.

132, Donghwagongdan-ro, Munmak-eup, Wonju-si, Gangwon-do, Korea

Tel: (82) 2 542 3375 (82) 33 742 5400

 OBELIS S.A Bd. Général Wahis, 53, 1030 Brussels, Belgium

MEDIANA reserves the copyright of this user's manual. Any contents or text of this manual can be modified without prior notice to the company. If you have any inquiries regarding this manual, please contact service center. Any manual containing misprints shall be sent again.

Document number : A7632-1

Revision date : 2020-02

Product Warranty

Product Name	I30 (Product number :)
Warranty	1 year from date of purchase
Purchase date	. . .

- The warranty is not valid if your issue falls into any of the following circumstances.
 - If non-MEDIANA staff or service provider performs unauthorized repair, installation, transport, or maintenance
 - When the product is damaged by other equipment
 - Damage by user's carelessness
 - If maintenance or repair is not performed with MEDIANA-authorized equipment
 - If you arbitrarily change the equipment or use non-MEDIANA-authorized components
 - Damage caused by natural disasters such as accidents, earthquakes or floods
 - Damage after the expiration date specified in this manual
 - In case of damage due to failure of the proposed maintenance method
- This warranty applies only to the hardware of this product and does not apply to loss or damage from included components or from improper operation.
- If any problem occurs with **I30**, contact local dealer.
- This equipment meets the EMC standard-IEC 60601-1-2.

i30 Body Composition Analyzer

Contents



1. Description	8
1.1. Basic Component	8
1.2. Install the product	9
1.3. Accessory	11
1.4. Connection of external equipment	11
2. Using Product	13
2.1. Name and Characteristics of Parts	13
2.2. Safety Precautions	16
2.3. Power On/Off	19
2.4. Body Composition Measurement	20
2.5. Checking Result	23
3. Setting	26
3.1. Menu	26
3.2. Database result	27
3.3. Measurement	30
3.4. Print	32
3.5. System setting	33
4. Service	37
4.1. Problem solution	37
4.2. Self-resolution	37
4.3. Recycling and disposal	40
4.4. Product return	40
4.5. Transportation and Storage	41
4.6. Maintenance	42
4.7. Regular safety check	43
5. Specifications	44
6. Manufacturer's EMC Declaration	45

Precautions for use

It is a description about cautions required for normal product use. Refer to WARNING and CAUTION in the chapters of this manual for more information.

Note! Carefully read and follow the precautions and product specifications specified in this manual before using the product. (N0001)



WARNING

Indicates possible risks of death, injury or side-effects or potentially serious consequence to the patient or user.

- Use grounding for medical equipment when using commercial AC power. It may cause short circuit hazards. (W0001)
- Do not use unauthorized component or option to prevent accidents. (W0002)
- Please read this manual thoroughly provided with related or optional components prior to operation. This manual may not contain warnings about individual components. (W0003)
- Unauthorized disassembly or cover opening may cause electric shock or fire hazards. Unauthorized repair or modifications to the product without manufacturer's approval is not covered by the warranty. (W0004)
- Connect the product to the designated power source to prevent electric shock or fire hazards. (W0005)
- Make sure that the equipment is in safe condition before use. (W0006)
- Liquid spill may cause electric shock or fire hazards, if it occurs, immediately unplug, wipe it off and contact service center. (W0007)
- Turn off the power and unplug power plug to prevent electric shock before maintenance. (W0008)
- If it smells suspicious or emits smoke, immediately turn off the power and unplug power cord. (W0009)
- Don't use damaged cable, device, or connector to prevent accidents. (W0010)
- Don't install the equipment where it is difficult to unplug the power cord. (W0011)
- Don't plug or unplug power cord with wet hands. It may cause a danger of electric shock. (W0012)
- Use extension cable or outlet with sufficient power capacity when using outlet with multiple terminals. (W0013)
- Be sure not to let this product in direct contact with other electronic devices in power. It may cause a spark hazard. (W0014)
- Use the model adapter provided by MEDIANA. Use of other adapters may cause equipment malfunction. (W0025)

 **CAUTION**

Indicates conditions or action that could cause damage to the equipment.

- Be sure to read the instructions before using the equipment for safety. (C0001)
- Equipment may not be operated properly if it is operated or stored in the environment not recommended by MEDIANA. (C0002)
- Dropping or hitting of the equipment may cause product failure. Do not use the product in failure. (C0003)
- Do not place anything on the equipment. There is a risk of equipment damage. (C0004)
- Do not operate near large equipment using switching relay. If the equipment experiences external interference, it may cause inaccurate measurement analysis. (C0005)
- If the equipment shares the same electrical outlet with other devices which could cause electrical interference, set them off on separate supply sources. (C0006)
- Turn on the power of other inspection devices first, when connecting **I30** to the inspection devices. If you want to turn off **I30**, power off the inspection devices first this time, then **I30** later. Electrical shock of the equipment can be minimized. (C0007)
- If the hand electrode is bent over its normal range of use or rotates excessively up, down, left and right, it may cause breakage issues. Do not apply excessive force to the hand electrode. (C0002)

1. Description

Body composition analyzer

I30 is a bioelectrical body composition analyzer which estimates body composition parameters based on bioelectrical impedance analysis (BIA). This device calculates and estimates body composition parameters by using weight and segmental impedance and frequency. Body composition analysis results may be of value to health care professionals in their management environments. The device is not intended to diagnose, manage or treat any medical condition.

1.1. Basic Component

The following are the basic components of the product. Make sure you have all the components.

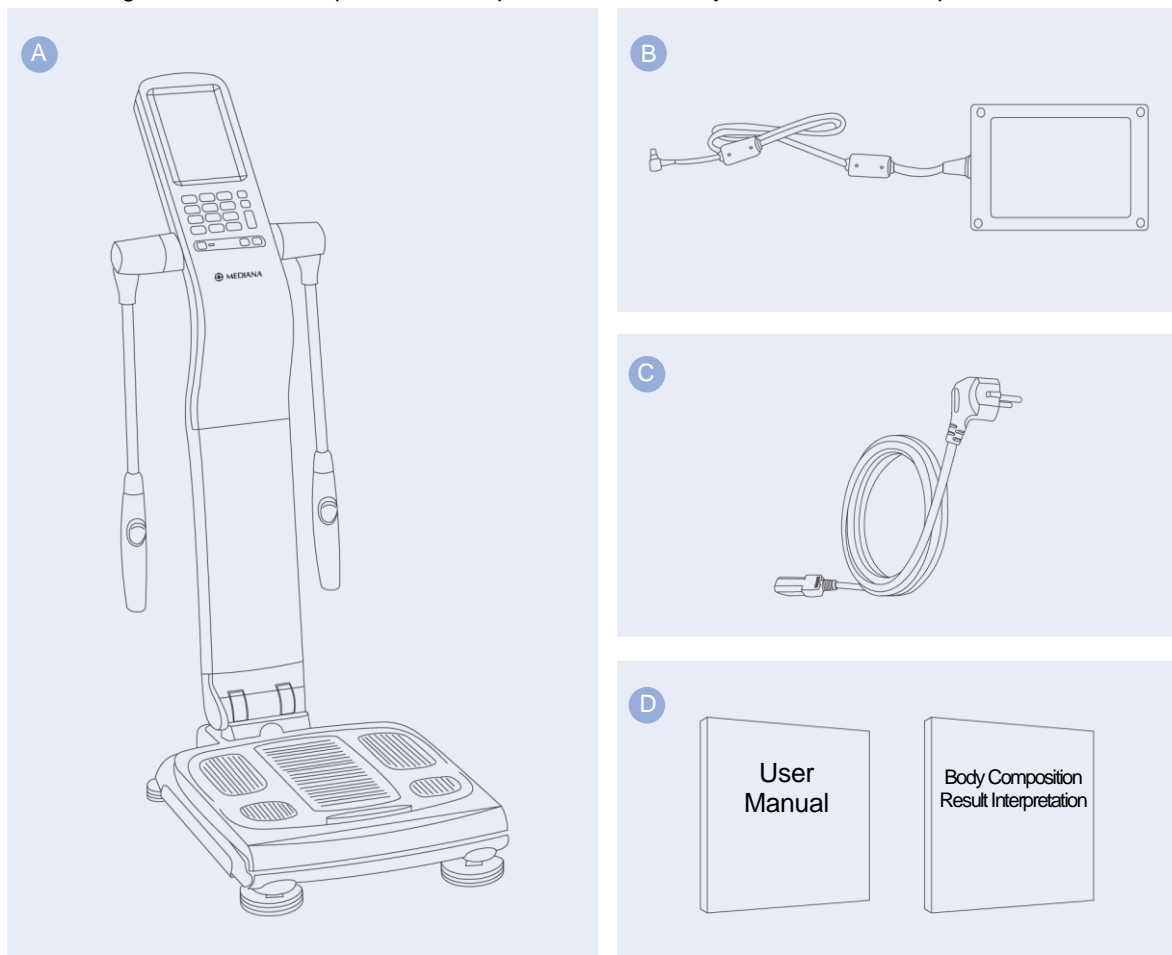

- A** I30 Body Composition Analyzer
- B** Power adapter (DC 12V, 5.0A)
- C** Power cable (AC 250V, 10A, 1.8m)
- D** User Manual & Body Composition Result Interpretation

1.2. Install the product

Check whether there is damage to the box. Please stop unpacking and contact local dealer or nearby service center immediately if signs of damage are spotted on the equipment or accessories. Also refer to the maintenance section.

- A. After unpacking **the box**, ① remove **the packing pad** and ② take out the **I30**.

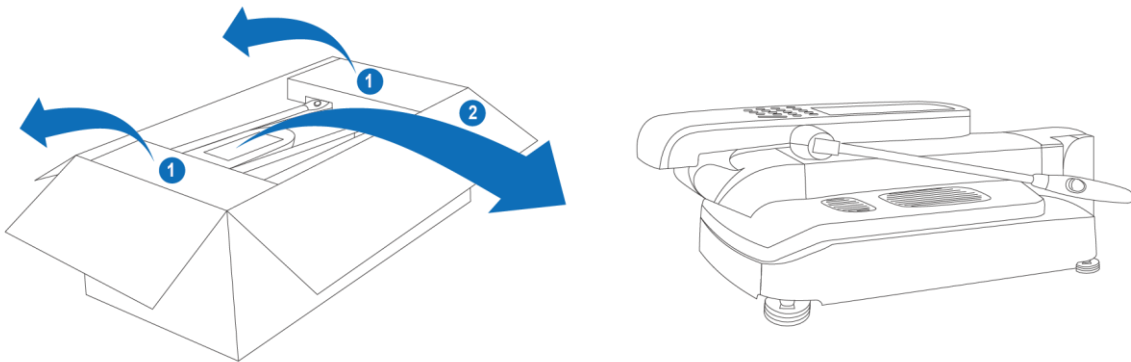

- B. Rotate the handle to the front and then raise the upper body with **the button of the lower body** pressed.

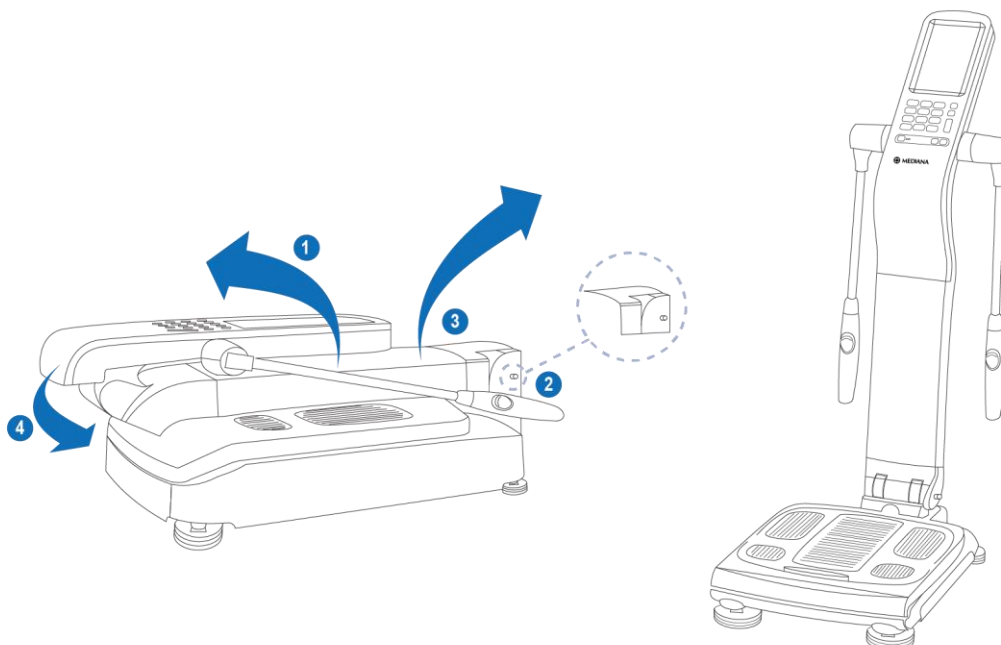

- D. Make sure the air bubble in **the level indicator** is centered by turning **the height adjustment screws**.

Equipment should be leveled and installed on flat floor. If it is not leveled, it may cause a risk of stumbling injury to the examinee, product damage, or inaccurate measurement control.

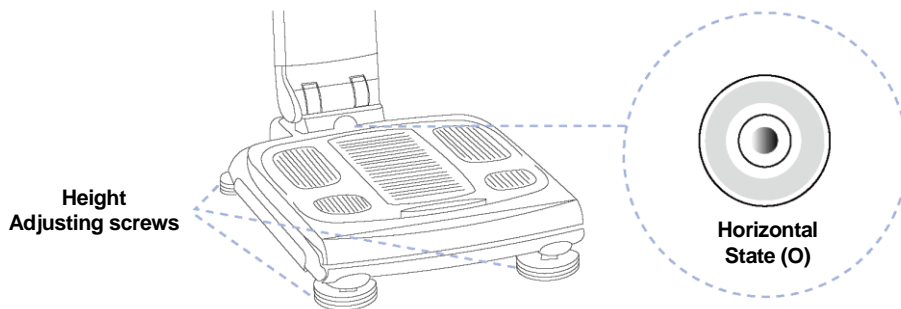

- E. ① After connecting the adapter to AC power, ② plug the AC power plug into the outlet. ③ Connect the adapter to the power input terminal on the back of the product.

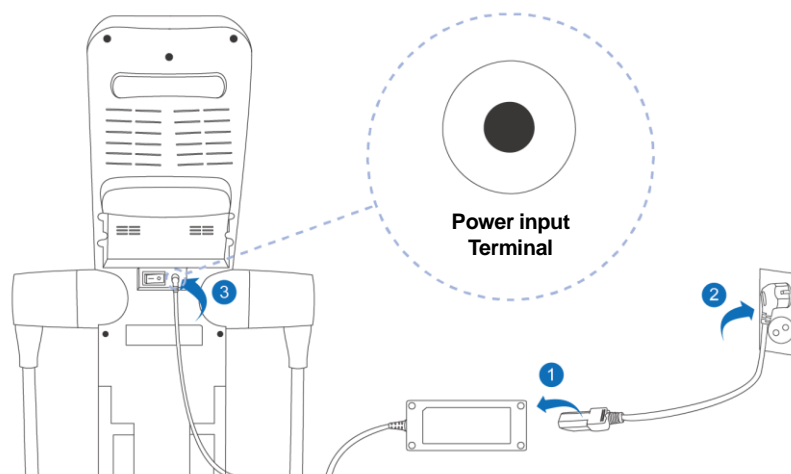

CAUTION

- While in use, connection should not be made through electrical outlets that use switches, as it may lead to the unexpected turning off of the equipment. (C0010)

WARNING

- To maintain measurement accuracy or performance and to prevent failure or damage, it should be protected from excessive moisture, such as direct exposure to rain. (W0015)

1.3. Accessory

The product configuration can be checked through the model options listed in the below table. Model option can be checked through product identification number that can be found on the back side of the product. All products are treated as full optioned ones in this manual, so please refer to the configuration table below, if products operate wrongly.

Option	A	B	C	D
I30 Basic Configuration	✓	✓	✓	✓
Barcode Reader		✓		✓
Wi-Fi/Bluetooth Dongle			✓	✓



• Depending on the region, the region code can be added. (N0002)

1.4. Connection of external equipment

A. Connecting the A4 Printer

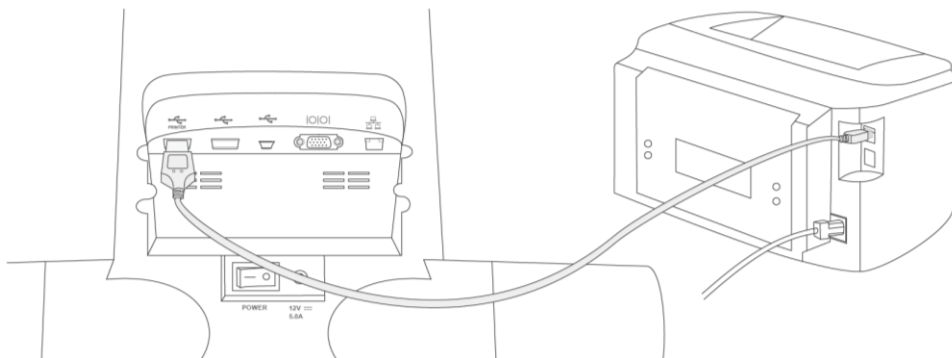

- ① Power off the equipment. Connect the printer USB cable to USB private port to back of the product.
- ② Connect the printer private USB cable to port on back of the printer.
- ③ Turn on the equipment and printer. Check the printer connection.
- ④ If printer is connected successfully, printer symbol (🖨️) will appear when + button at the top of the screen is pushed.





• Output position can be adjusted in 'adjusting printer paper output position' menu in setting. (N0003)
 • Available printers can be checked on the manufacturer's website. (N0004)

B. Connecting Barcode Reader

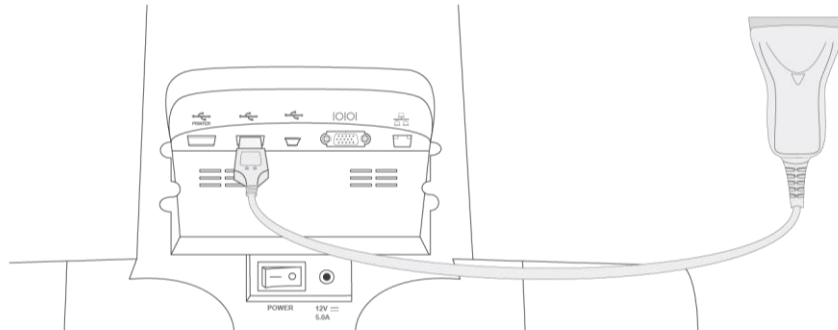
Barcode reader can be used to enter the subject's ID.



- ① Power off the equipment.
- ② Connect the USB cable to the right USB port on the back of the product.
- ③ Turn on the equipment.
- ④ If barcode reader is connected successfully, barcode reader symbol () will appear when  button at the top of the screen is pushed.

2. Using Product

2.1. Name and Characteristics of Parts

A. Front

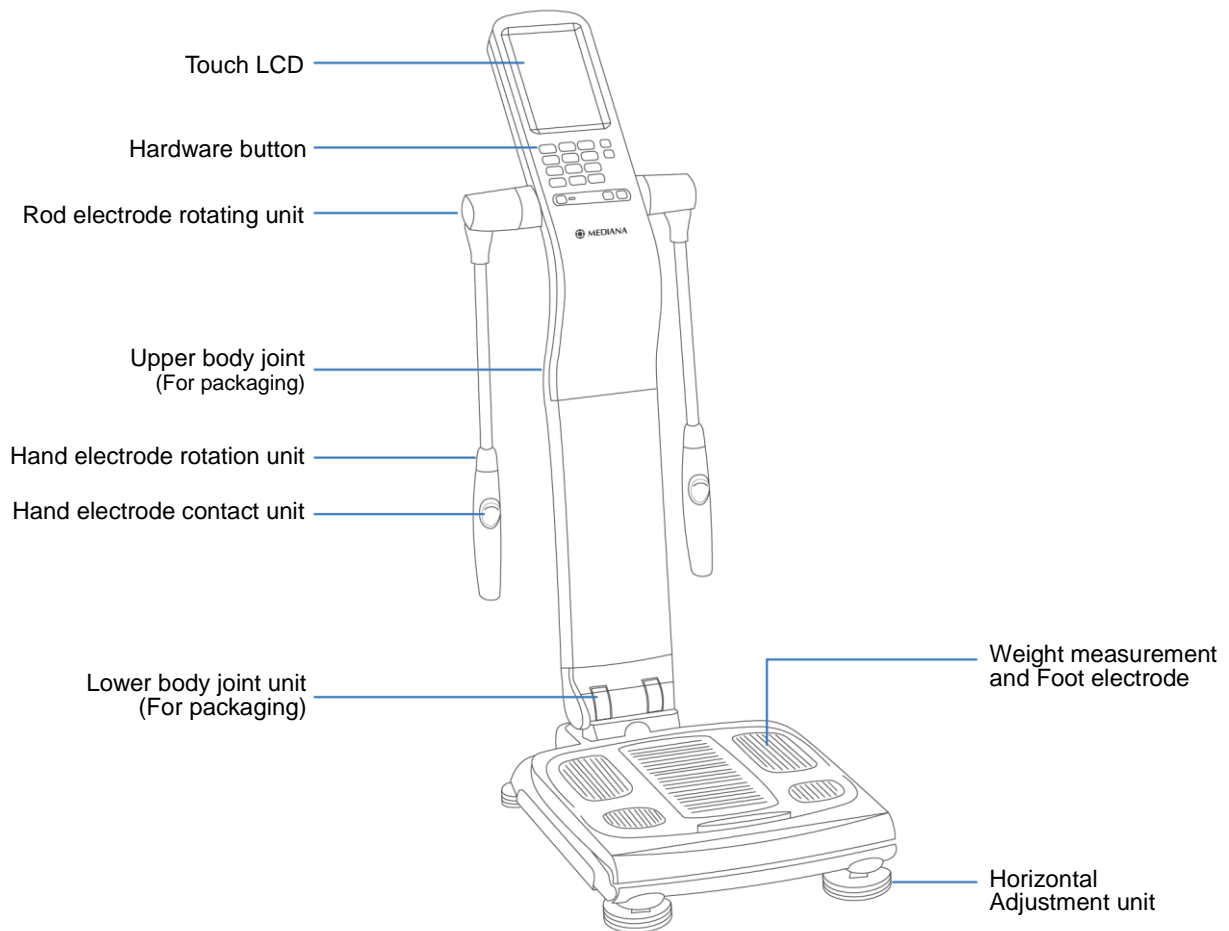

B. Back

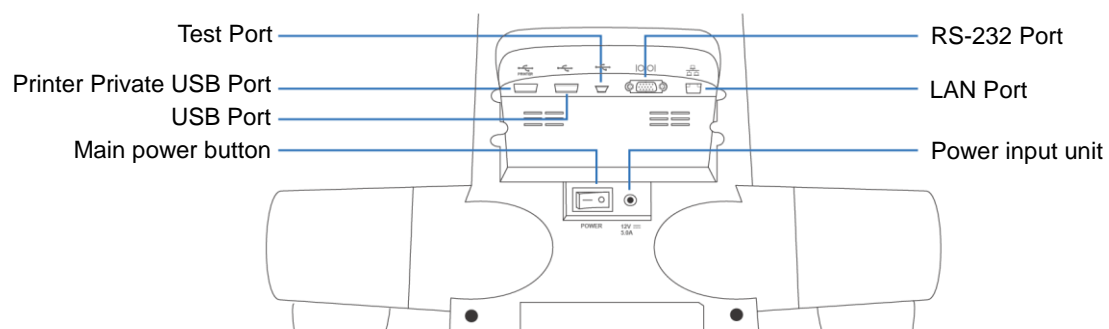

C. Hardware Button

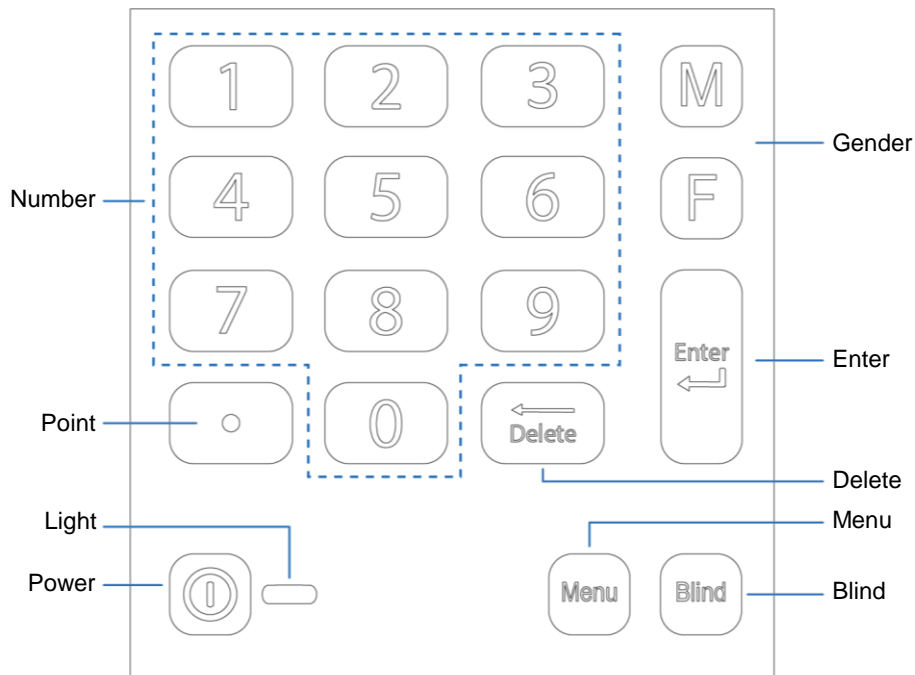

Button	Function
Power	<ul style="list-style-type: none"> If you press it for more than 1 second when power is off, the power indicator turns green and the power is on. If it is pressed for more than 2 seconds with power on, the power is turned off and the light changes to red.
Number	<ul style="list-style-type: none"> You can enter number in weight, personal information and menu.
Gender	<ul style="list-style-type: none"> You can choose gender as male (M), female (F) when entering personal information.
Point	<ul style="list-style-type: none"> You can enter decimal point when entering personal information.
Enter	<ul style="list-style-type: none"> You can complete the entry after entering the information.
Delete	<ul style="list-style-type: none"> You can delete the entered information one space at a time.
Menu	<ul style="list-style-type: none"> You can enter the menu.
Light	<ul style="list-style-type: none"> Orange indicator : Ready, Green Indicator : System operating
Blind	<ul style="list-style-type: none"> You can hide sensitive measurement results displayed on the screen. You can disable the blind function by pressing the button once again while the blind function is on.

○ Mechanical Feature

- The size of this product is 360 (W) X 559 (L) X 1077 (H) (mm). It allows for portable use and easy transport, with a simple-push-button-fold system and hand grip.

○ Electrical Feature

- Adapter power input: AC 100-240V, 50-60Hz, 1.5A (1.5-0.7A)
- Adapter power output: DC 12V. 5.0A

○ Display

- This product uses 7-inch color LCD touch screen. This enables simple and easy operation.



- Refer to the operation check section of the service manual for details on how to use the touch screen. If there are any problems with key-pad operation and touch screen selection, contact local dealer or service department. (N0005)

○ External Interface

- This product supports RS-232 and USB interface. It offers USB ports to support printer and barcode reader connections. Update of main programs, or back-up & restoring measurement data and exporting to PC are also available through USB interface.

○ Network Settings







- Wired connection: LAN cable can be connected to the external communication port on the back of the device to connect the device to a local area network (LAN) that uses a wired connection.
- Wireless connection: This product can be connected to the network using a wireless connection (Wi-Fi, Bluetooth). It can be set only by the personnel authorized on the service menu.















- Bluetooth and Wi-Fi dongle use items in accordance with the electrical appliances safety control act. (N0023)

2.2. Safety Precautions

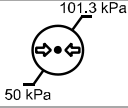
A. Display Item

Symbols	Description	Symbols	Description
	Manufacturer		Manufacture Date
	Product serial number		Product configuration number
IOIOI	Serial Port		Connection type: LAN
	Connection type: USB		Connection type: Printer private USB

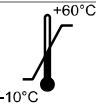
B. Safety Sign

Symbols	Description	Symbols	Description
	Power on		Power off
~	AC power supply		BF type mounting portion
==	DC power supply		EU representative information
	CE mark		See user's Manual
	Storage direction		Transport / Storage pressure
	Moisture blocking		Transport / Storage humidity
	Handle with care		Transport / Storage temperature
	Follow guidelines for proper disposal		

C. Product Category

Protection type against electric shock	CLASS I
Degree of protection against electric shock	BF type
Degree of protection against immersion	Same degree of water protection as shell coverings that offer no liquid protection, IPX0.

✘ This device is not suitable for use in the presence of flammable materials.

D. Functions for safe use

The intended operator of this product should have received qualified product training and the main functions that can be used safely are as follows.

Weight measurement	Weigh the weight using the load cell and check the result on LCD.
Body impedance measurement	Body impedance is measured by sending a weak, harmless electrical current through the hands and foot electrodes. Body composition results can be checked on the LCD screen after measurement.

E. Compliance

Classification	Standard	Title
General	93/42/EEC as amended by 2007/47/EC	Medical Device Directive (for EU)
	IEC 60601-1:2005+A1:2012 EN 60601-1:2006+A1:2013	Medical electrical equipment - Part 1: General requirements for basic safety and essential performance
	ISO 13485:2003/Cor1:2009 EN ISO 13485:2012/AC:2012	Quality systems - Medical Devices - Requirements for regulating purposes
EMC	IEC60601-1-2: 2014 EN 60601-1-2:2007/AC:2010	Medical electrical equipment – Part 1-2: General requirements for basic safety and essential performance – Collateral standard: Electromagnetic compatibility – Requirements and tests
Risk Analysis	EN/ISO14971:2012	Medical Electrical Equipment - Software Safety Requirements
Programmable Electrical Systems	IEC 62304:2006+A1:2015 EN 62304:2006/AC:2008	Medical device software – Software life cycle processes
Usability Study	IEC 60601-1-6:2010+A1:2013 EN 60601-1-6:2010	Medical electrical equipment - Part 1-6: General requirements for basic safety and essential performance - Collateral standard: Usability
	IEC 62366:2007+A1:2014 EN 62366:2008	Medical devices - Application of usability engineering to medical devices
Package	ISTA: Pre-Shipment Test Procedures (Procedure 2A, 2014)	Pre-Shipment Test Procedures (Package)
Scale	OIML R76-1:2006	Non-automatic weighing instruments Part 1: Metrological and technical requirements - Tests
	OIML R76-2:2007	Non-automatic weighing instruments Part 2: Test report format



WARNING

- Measurement is prohibited for individuals with an internally implanted Pacemaker. (W0016)
- Measurement is prohibited for those whose use of electrodes may cause skin problems. (W0017)
- Jumping or playing on the footplate is prohibited due to possible personal injury. (W0018)
- Pregnant women need to consult with doctors or experts first before measurement. (W0019)
- Ask help from the manager in charge, if you are a child or having difficulty measuring yourself. (W0020)
- Measurement is prohibited for individuals with any kind of contagious disease or whose infected wound can have direct electrode contact. (W0021)
- Measurement result of this product is for reference purpose only and should not be used for treatment purposes based on the user's unprofessional judgment. Consultation with doctor or certified specialist is required for accurate result analysis. (W0022)



Measurement Recommendation

- Observe the following for accurate measurement. (N0006)

- Recommended to measure on an empty stomach.
- Recommended to measure after urination and excretion.
- Recommended to measure before taking a bath.
- Recommended to measure before exercise.
- Recommended to measure as regularly as possible.
- Stand upright for about 3 minutes before taking the test for more reliable results.
- Excessively high or low body temperature can cause measurement errors in composition analysis.
- Wear light clothes and take off jewelry before measurement.
- Dry limbs or excessive calluses may hinder accurate measurement. Wet-wipe your palm and sole before measurement.
- Large surgical scars or skin problems may lead to reduced analysis accuracy.
- Operation at the altitude of higher than 2,000 meters may affect weight measurement.

2.3. Power On/Off

Make sure that the product is working properly, before using it. The following explanation helps with how to operate the power button.

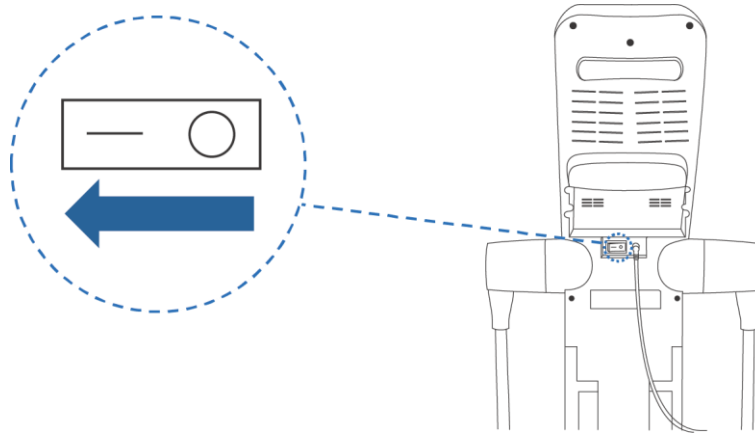

A. Power On

With the switch on the back of the product turned on, press power button  for more than 1 second. Then, it starts and the loading screen will be displayed after the normal operation test.



- If the power doesn't turn on, check that the power cord is fully inserted into a grounded outlet and that DC connector jack of the adapter is fully inserted into the power input socket of the equipment.

(N0007)

B. Power Off

Press the power button  for more than 2 seconds with it turned on. So the equipment will be shut down. To turn off the switch on the back of the product will cut power to the device.



CAUTION

- Please do not put anything on the device to avoid malfunction of weight measurement. (C0028)
- When the power is turned on, the normal operation test (POST) is executed automatically to check that the circuit or function is working properly. For running the normal operation test (POST) you should check whether the screen is on or the startup sound is heard. If the screen doesn't work properly, don't use the equipment and immediately contact local dealer or service center. (C0011)
- When finished with using the equipment, press the power button to turn off the equipment first, then turn off the power by pressing the switch on the back of the unit. If the power is turned off suddenly while the screen is on, the equipment may be damaged. (C0012)
- Keep the switch turned off, if the equipment will not be used for a long period of time. (C0013)

2.4. Body Composition Measurement

1. When you step on the weighing platform while [the home screen] is turned on, it will automatically start to measure weight first.

- If you take your socks off and stand on your feet, you can easily proceed with body composition measurement after measuring weight.

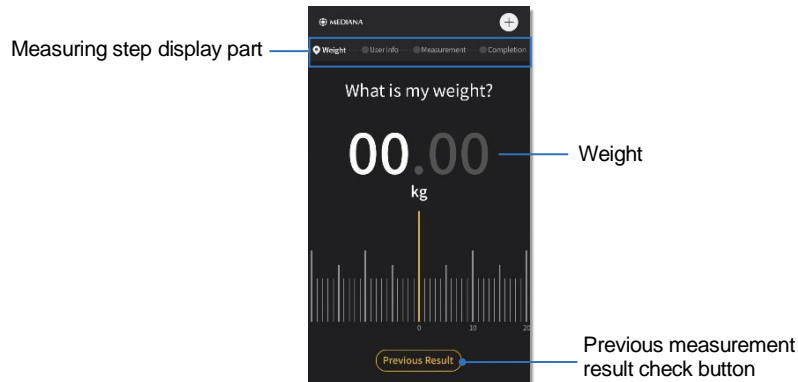

2. Select how to enter member ID (Existing member, Registration, Non-member) on [the information input screen].

- If you press **Non-member**, follow step 4. Results are not saved in non-member use of the equipment.

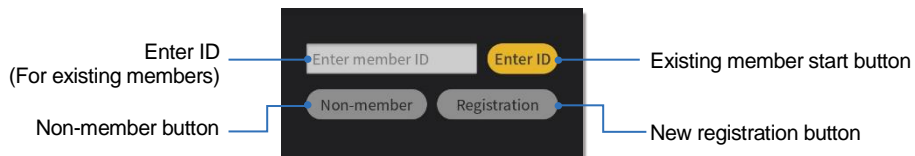

3. Enter ID using [ID Input Keypad] or [Button Input] and press **Enter ID**.

- ID can be input using up to 20 characters of English alphabet or symbols.

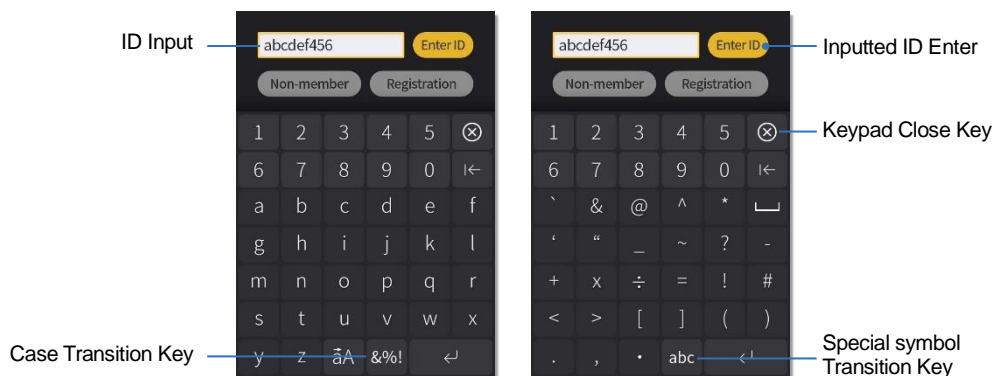

4. Input necessary user information for measurement and press **Next** .

- For non-member use, select Gender and enter Height and Age.
- For new registration, select Gender and enter Height and Age. Name, Waist circumference and Hip circumference are optional inputs.
- It shows up saved information for existing members. Personal information can be changed, if needed.

[User information input screen]
Non-member / Registration

- Gender: Touch input or Press **M** , **F** of [Button Input].
- Height: Touch input box and Enter it using [Numeric Key] and **.** button to the first digit decimal place.
- Age: Touch input box and Enter it using [Numeric Key] by integer.
- Name: Touch input box and Enter it using language and special symbols to 20 characters.
- Waist (circumference): Touch input box and Enter it using [Numeric Key] and **.** button to the first digit decimal place.
- Hip (circumference): Touch input box and Enter it using [Numeric Key] and **.** button to the first digit decimal place.

5. Take a proper measuring posture following voice and screen guidance.

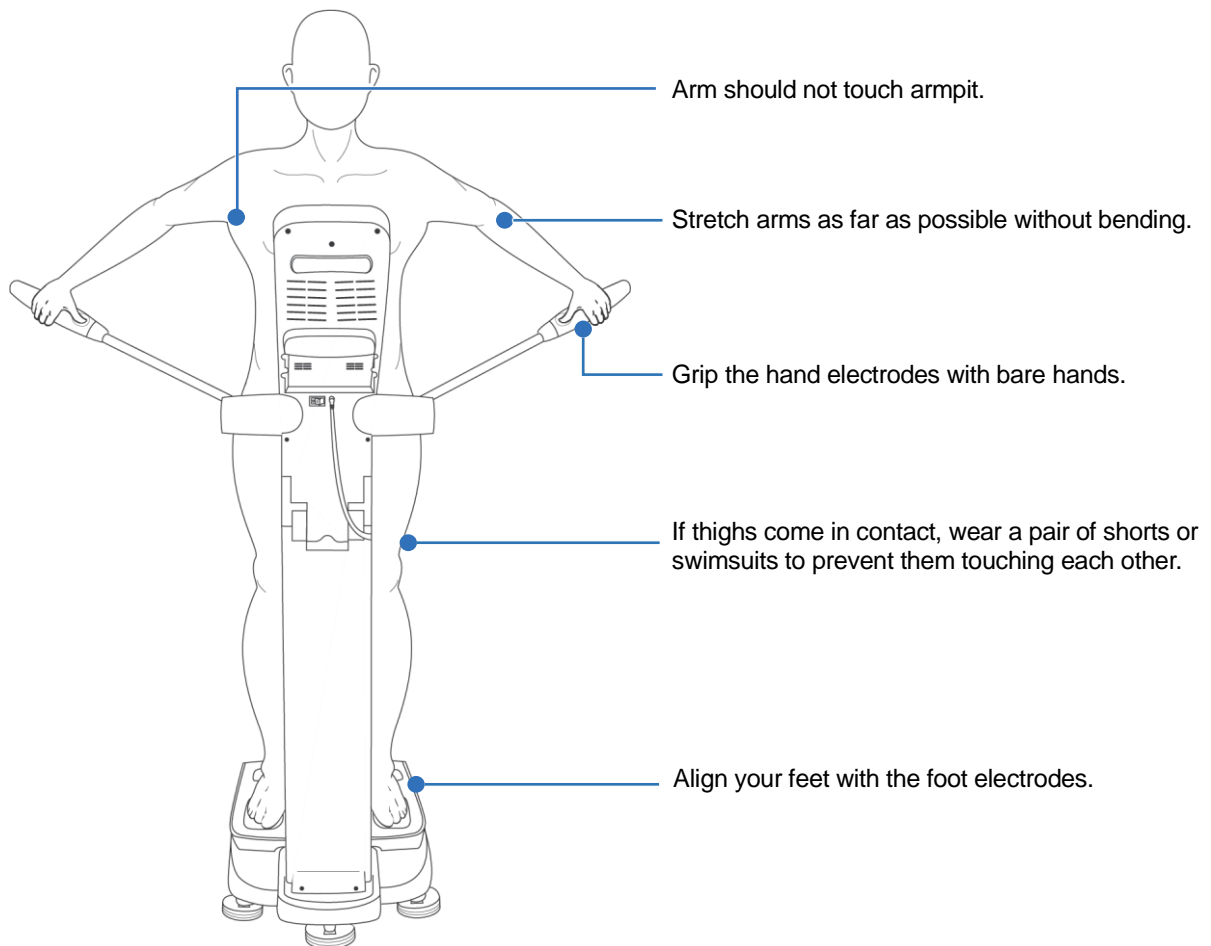

CAUTION

- If hands, feet and the electrodes are not in full contact, a contact failure message will appear. If it appears, you should follow through the instructions, take a correct posture and measure again. If the error persists, contact service center. (C0014)
- Do not push the hand-electrode to the direction of outside to avoid damage of the joint part of hand-electrode. (C0029)

2.5. Checking Result

After measurement is completed, it displays the results of the main body composition on the LCD screen. You can switch **[the result screen]** using **[the button of bottom]**.



A. Body Composition Graph

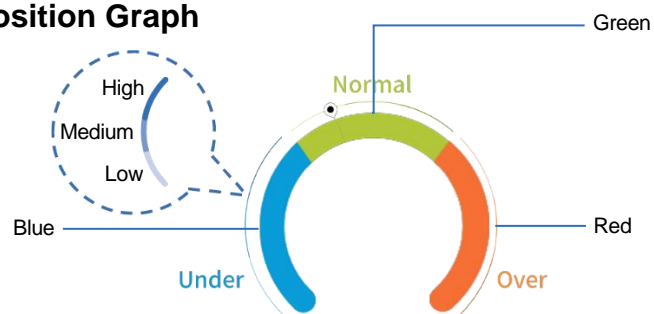





The circular gauge chart displays body weight, muscle mass and body fat percentage, with three different color indicators. You can have even more detailed information from the distinctly graded color difference of the outline of each status ranging in High, Medium, or Low.

○ Standard Weight and Targeted Weight Achievement

- It informs standard weight based on analysis results and the amount of muscle & body fat that you need to control for targeted weight achievement.

B. Body Type

Check **comprehensive score, body type, balance analysis result.**

- Screen can be switched by touching ,  buttons or , ,  buttons on the top right corner of the screen.

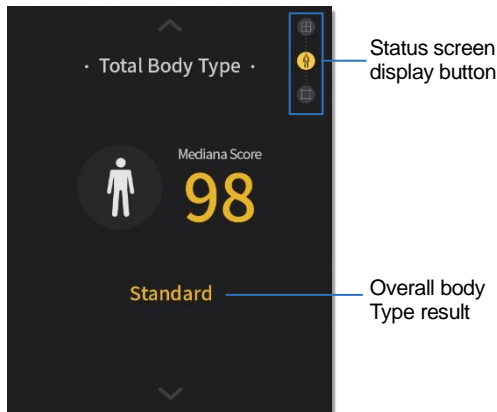

- MEDIANA score assesses how healthy the user is utilizing MEDIANA's own patented technologies based on measuring body fat and muscle mass. People who exercise a lot tend to have less fat and high muscle mass. The less body fat and more muscle mass you have, the higher MEDIANA score assesses.

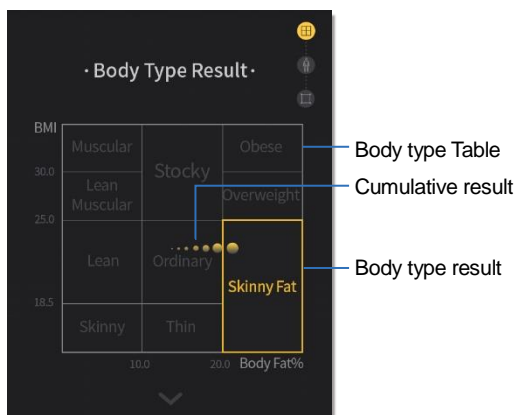

- It shows what type of body you belong to based on BMI and body fat percentage. Body type table displays fixed images based on BMI (Y axis) and body fat percentage (X axis). The yellow box defines the user's body type. Cumulative measurement result points can be shown up to 5 points.

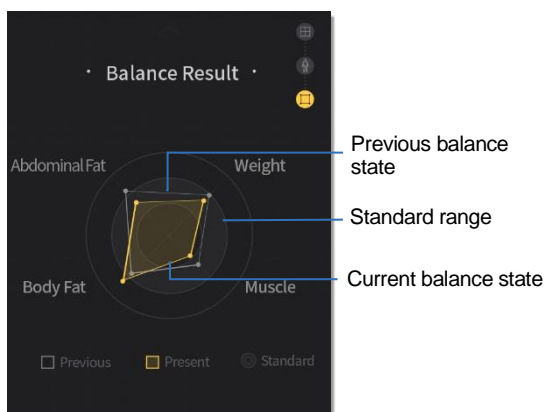

- Weight, muscle mass, body fat percent and abdominal fat are displayed by quadrilateral shape to analyze the balance. As shown in the symbol below, yellow rectangle represents the current balance state and the gray represents the previous balance state. The donut of dark gray shows the standard range. The square shape is in the standard range and the closer it is to the square, the more balanced the body.

C. Body Composition Change

Changes of weight, muscle mass and body fat percentage can be sorted by period.

- Press **Weight(kg)** **Muscle(kg)** **Body Fat (%)** button to reveal / hide each item.
- Press **All** **12 mo.** **6 mo.** **3 mo.** **Recent** buttons, if you have a specific period in mind to review changes.
- Select speech bubble pointing to the maximum or minimum value to check data for that day.

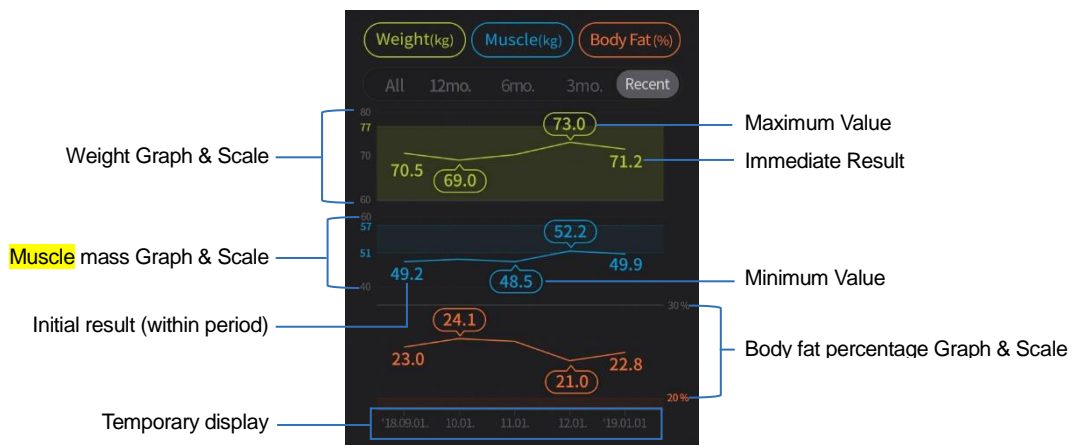

- If the measurement data contained in the period is less than 2 times, button of the period is not displayed. (N0008)

o Standard range comparison

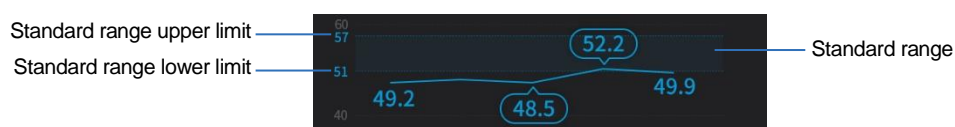



- It allows users to effectively compare analysis results over **standard range** of body composition, along with body compositional history. If the result sits above standard range, you need to lose weight. If you are under standard, it requires more positive weight & muscle gain. If you find the **standard range area forming a small band shape**, it means a possible measurement discrepancy between the result and standard range.

3. Setting

3.1. Menu

Helps you to manage **I30** settings.

A. Configuration Introduction

Press  on the button input, or press  on the home screen and press  to enter the set-up menu.



• See below for how to control screen display or time / date settings. (N0009)

B. Menu Selection

- ① Enter 4-digit password using [Number pad].
- ② Default password is "0000". Enter new password once you reset.
- ③ Menu list will appear if you enter password. Select the menu to set.



• Click [Password Reset] and follow the instructions, if you forget password. (N0010)

C. Menu Type

- Database Result : View again, Delete, Print, Search, Export, Control (Backup, Restore, Merge)
- Measurement : Measurement mode and information input method, Clothes, Measurement standard value and standard range
- Print : Result Sheet, Auto Save, Auto Print, Auto Print Count
- System : Default setting (date, screen, volume, brightness, measurement unit, country, language, communication), Print location, Home screen, User logo, Password setting, System(reset, backup, restore)
- Maintenance: Test (LCD, sound, Injection current, touch, key, barcode reader, external memory, network), SW version check and update



• Access to Maintenance menu is primarily for the service engineer. Unauthorized control of Maintenance setting is not recommended. (N0011)

3.2. Database result

Stored measurement result data is listed in time order starting from the top.

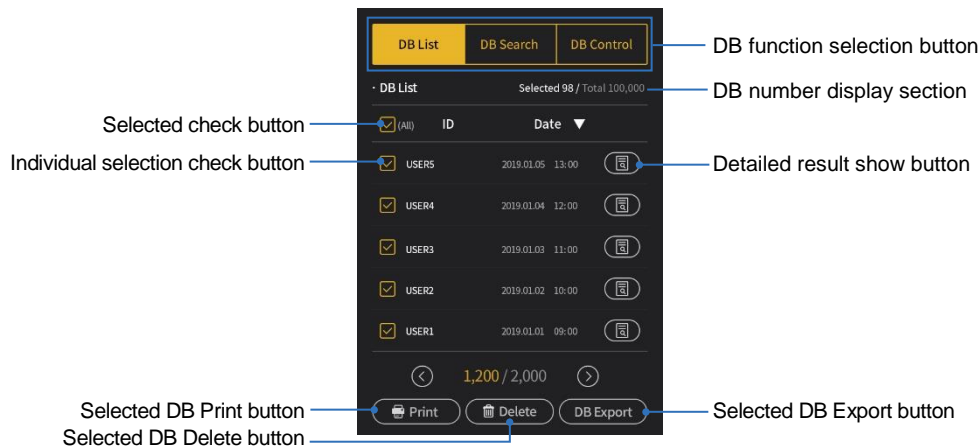

A. Using basic functions

- Select All : Press [Select all check button] to select all saved data. Press [Select all check button] again to clear all selections.
- Individual selection : Press [Individual selection check button] to select the corresponding data. Press [Individual selection check button] again to cancel the selection.
- Show detailed results: Check the saved data in the result view screen in detail.
- DB Print : Select the data to print, Press . It will be output in the order listed.
- DB Delete: Select the data to delete, Press to delete.
- DB Export: Select data to export to external storage media, Press to run the export. For detailed exporting method, refer to [Inserting external storage media] on the next page.

CAUTION

- Deleted data can't be recovered. (C0015)

B. DB Search

- ① Press the [DB Search] button on the top to display the DB Search screen.
- ② Enter the measurement period or ID to search by using [Button input section] or [Keypad button].
- ③ Entering either one of them does turn up the results. Entering both helps to get more specified results.
- ④ After input, press **Search** to display DB list that meets searching conditions.
- ⑤ If you want to change search contents, press **Re-search** at the bottom.



• If you enter measurement period, you should enter the year, month and day. (N0012)

C. DB Control

Press the **[DB Control]** button at the top to execute DB backup, restore and merge.

- Backup: Whole database stored in device is copied to external storage media.
- Restore: Whole database stored in device is deleted and the DB stored in external storage media is copied.
- Merge: Keeping original database in device, database stored in external storage media is copied.



- When database is restored, all existing data will be deleted. (C0016)

○ Inserting external storage media

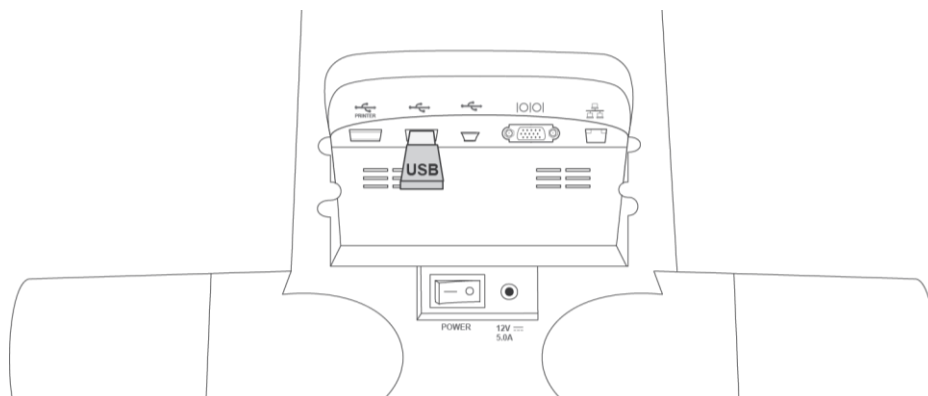

○ DB Export / Backup

- ① Insert to the right USB port USB to save database as shown in the [Insert the external storage media] figure.
- ② If you click **DB Export** or **DB Back-up**, a screen appears to confirm your selection.
- ③ Press **OK** to see the progress indicator. Don't remove the USB during the process.
- ④ When completed, close the popup screen, remove USB and check database on PC.

CAUTION

- USB for FAT / FAT32 file systems is recommended. If USB from another file system is used, format is required. In this case, all existing data stored in USB will be deleted. (C0017)

○ DB Restore / Merge

- ① Insert to the right USB port USB that has database to restore or merge as shown in the [Insert the external storage media] figure.
- ② If you click **DB Restore** or **DB Merge**, a screen appears to confirm your selection.
- ③ Press **OK** to see the progress indicator. Don't remove the USB during the process.
- ④ When completed, close the popup screen, remove USB and check the database List.





• If there is no normal DB file in USB, you cannot proceed further. (N0013)

3.3. Measurement

This menu is to set measurement mode of the equipment and the standard value that affects body composition evaluation. Select the sub menu to set at the top.

A. Mode

Refer to the following description and switch on / off for the test mode (expert / self-test) you want to use.

- **Expert Test Mode** is suitable when 'expert operators' are present for help throughout all body composition analysis process. Body composition measurement starts when you touch  button on the posture guidance screen and here, expert operators can decide, based on their professional opinions, either to skip the guidance process, or have the user trained properly.
- **Self-Test mode** is suitable when you measure yourself. When measurement starts after personal information has been entered, it automatically progresses throughout the test, without separate steps necessarily taken.
- **Blind mode** helps to keep on-screen analysis results in private, so the examinee avoids revealing otherwise sensitive analysis parameters like obesity degree. You may turn it on / off on system settings or using  button. You still can make sure that all analysis results, though blind mode is on, are printed on results sheet.
- **Classmate mode** is gender-and-age-specific analysis for measuring different groups of subjects. At the start of new measurement, ID, age and gender entered in the previous measurement are automatically entered.



• Automatic input of gender, age and ID on Classmate Mode is saved until the rebooting of the equipment. When the instrument is rebooted, it returns to the previous measurement mode. (N0014)

• ID Auto-input will have its last 6 digits increased by 1 on every measurement after you take the initial measurement.

ⓘ (Example) If the first entered ID is [USER], the second ID will be [USER000001] and the third ID will be entered [USER000002]. (N0015)



B. Information

○ Weight measurement setting

Press  to set whether to measure or input weight.

- Input: When the user steps on the footplate, the user can input weight manually on screen, using **[Numeric Key]** and **[Point Key]**.
- Measure: When the user steps on the footplate, with the measurement screen on, weight measurement begins automatically.

○ Clothes

This function is used to subtract and compensate for the weight of clothes the examinee is wearing for more accurate measurement. You can adjust the weight of clothes by 1 kg unit within total range of 5.0kg by pressing ,  or using **[Numeric Key]** and **[Point Key]**.

○ User information

Press  to hide / reveal optional user information such as name, waist circumference and hip circumference on the information input screen.

C. Standard Setting

○ Standard value and range

- You can change the BMI, body fat percent standard and standard range.
 - ① Press  button or select the input box to edit and fill it using **[Numeric Key]** and **[Point Key]**
 - ② If you touch **[Enter button]**, or touch out of the box, input is completed.



○ Reference setting

- Select  buttons in the following menu: [Child BMI Standard, Child Growth Graph, Circumference standard, Segmental Fat standard, Segmental muscle standard] and select any standard in the list given.



- The input range can't exceed the set range based on clinical knowledge. (N0016)
- The user can make any customizations in the Child Standard BMI setting, and is able to directly input BMI standard range. Click **[Reset Setting]** to reset the customized child standard BMI value. (N0017)



3.4. Print

This menu related Measurement result printing. You can see all setting items by touching   buttons below.

A. Result Sheet setting

Press ,  or  in order to set sheet format of analysis results output.

If not set, the default output format is used.





- Child Result: It is basically for children body-composition analysis and offers relevant analysis results. If you have selected [Child result], age can be set with ,  buttons.
- Thermal Result: When Thermal printer is connected, minimal outputs are given. If [Thermal result] is selected, set whether to activate glossary and graph display, using .

B. Result Sheet selection



Press  to set the paper to print the body composition measurement result.

- Dedicated paper: select it if you want to use "MEDIANA"-authorized sheet in the pre-set frame.
- A4 paper: Select it to use regular A4 paper.

C. Auto print and count selection

Press  to select whether to print the result automatically or not. Press , , to set the number of sheets to print automatically. In non-automatic printing mode, it can be output manually using  button on the result screen.

D. Result Auto save selection



Press  to select whether to save the measurement result automatically or not. In non-automatic saving mode, it can be saved manually using  button on the result screen.

3.5. System setting

This menu is for managing the equipment system. Select **[Advanced Menu]** button to set up at the top.





A. Date / Time

You can set the date and time displayed on the device and result and set the screen saver activation.

- Date / Time : After selecting the input box to change, press ,  to move up and down or **[Numeric Key]** to input directly.
- Date Format : you can change order of year, month and day the way you want it displayed on screen.
- Screen Saver Time : If no screen input is made for a certain length of time, it activates into screen saver mode.





B. Condition

You can adjust the volume and brightness of the equipment and change the weight / length unit.

- Volume control: Press ,  to select the desired volume level.
- Brightness control: Press ,  to select the desired brightness level.
- Weight / Length unit: Press  to select the unit of weight [kg / lb] and the unit of length [cm / inch].

C. Print Location

If the print has alignment issues, you can adjust its printing position so they print out in clear alignment.

- ① Keep pressing , , ,  until you see results fit in with the frame of test paper.
- ② Press [Print Test] button at the bottom to check the adjusted result.



• Press the  button to reset the adjusted position to the center. (N0018)

D. Network / System

You can set LAN, Wi-Fi and Bluetooth communication.

o LAN Setting

- ① Press the [LAN] button to display the setting screen about IP, Gateway, Net mask.
- ② After selecting the box to input, press [Numeric Key] or [Point Key] to input value directly.
- ③ If input is completed and press [LAN Activate], and the setting is applied.

o Wi-Fi Setting

- ① Press the [Wi-Fi] button, and press [Scan AP] button on the next screen. After searching peripheral AP automatically, display the list.
- ② Select AP to connect and press [Connect].
- ③ When connecting to the encrypted AP, press [Keypad] to input password.
- ④ In a minute, a screen appears with assigned AP to connect Wi-Fi.

o Bluetooth Setting

- ① Press [BT On] button in the screen to put the [Bluetooth] button.
- ② In a minute, a screen appears Waiting message and dongle Mac Address.
- ③ Check Mac Address consistent with that of [I30] to search in Bluetooth setting of connecting device.
- ④ If pairing is successful, the connected device can communicate with the SPP profile.

o System

System setting can be initialized, backed up and restored.

- Initialize: Press the button to initialize the device setting to the initial setting.
- Backup: When the button is pressed, the system configuration file of the device is copied to the external storage media.
- Restore: Press the button to reset the device using the system configuration file stored in the external storage media.



- If the system is initialized, it can't be recovered to the previous system. (C0018)

○ Inserting external storage media

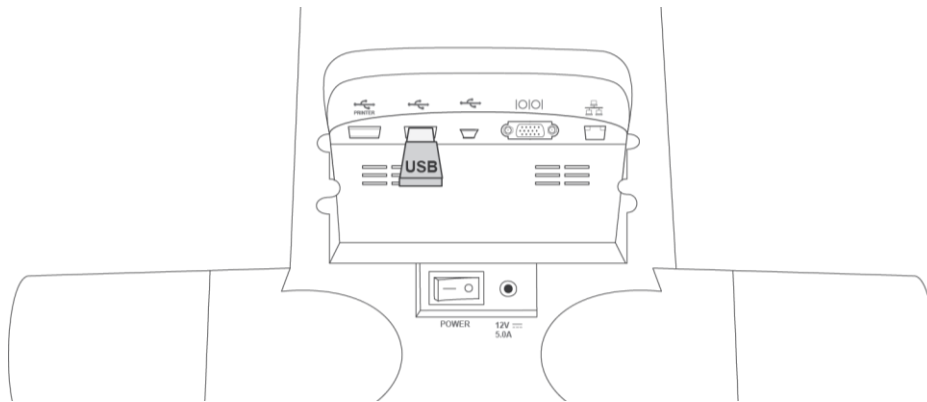

○ Back up system setting

- ① Insert to the right USB port USB to save system file as shown in the [Insert the external storage media] figure.
- ② If you click **Backup**, a screen appears to confirm selection.
- ③ Press **OK** to see the progress indicator. Don't remove the USB during the process.
- ④ If completed, close the pop-up screen, remove USB and check system file on PC.

⚠ CAUTION

- USB for FAT / FAT32 file systems is recommended. If USB from another file system is used, format is required. In this case, all existing data stored in USB will be deleted. (C0017)

○ Restore system setting

- ① Insert to the right USB port USB containing the system file you want to restore, as shown in the [Insert the external storage media] figure.
- ② If you click **Restore**, a screen appears to confirm selection.
- ③ Press **OK** to see the progress indicator. Don't remove the USB during the process.
- ④ If completed, close the pop-up screen, remove USB and check the setting.

E. Home screen type setting

Press **Home** to the home screen to set up. Changed home screen will be displayed in preview. **[Scale]** type displays scale indicator and numbers. **[I30]** type displays body composition analyzer device image and measurement guide message.

F. User logo setting

Set the logo displayed at the top of result sheet.

- File Import: To use a logo image, insert USB containing the saved images, select the image to use from the list and press **Save** button.
- Direct Input: Enter the logo using **[Button Input]** or **[Keypad]**, then press **[Enter Button]**.



- Logo image file type can only be a JPG, PNG, or GIF file. (N0024)
- If file name contains characters other than English or numbers, it may not be displayed properly. (N0025)
- Larger image than 500 x 120 px can't be printed properly. (N0019)

G. Country / Language

Change the country / language setting of the device. Press **Change** and country or language can be changed on list.



- When changing the country, a screen appears to ask whether to change the language and body composition standard range together. If you click [Yes], all country-specific options (Language, Standard range, Reference, etc.) are changed collectively. If you click [No], it only affects country setting. (N0020)

H. Password Change

Enter 4-digit password using **[Numeric Key]** and press **Save**.

4. Service

If technical information is needed, contact local dealer or service center and order the service manual. Service manual contains useful information such as how to inspect or repair **I30**. When contacting service center, let them know the software version of the equipment.

4.1. Problem solution

If there is a problem with the equipment, error code is displayed. Error code is listed in service manual. If error code appears on the screen, read it first and contact service center. Make sure that power connection is secure before contacting.

4.2. Self-resolution

Possible problems and self-corrective action is as follows.

Problem	Problem solution
If the device doesn't turn on when you press power button.	<ul style="list-style-type: none"> • Check the power connection. • If problem persists, contact service manager.
Screen doesn't appear or is distorted.	<ul style="list-style-type: none"> • Remove the power connection. After a while, reconnect and press the power button. If it doesn't operate normally, contact service manager.
If weight measurement result is not accurate.	<ul style="list-style-type: none"> • Make sure the equipment is installed on a flat, stable floor. Turn height adjustment screws beneath the footplate to set it level.
If sound is not working.	<ul style="list-style-type: none"> • Make sure the volume is set adequately. • If problem persists, contact service manager.
If date and time don't match.	<ul style="list-style-type: none"> • Set date and time in [Date & Time menu]. • If problem persists, contact service manager.
If power is interrupted abnormally.	<ul style="list-style-type: none"> • Remove the power connection. After a while, reconnect and press the power button. • If it doesn't operate normally, contact service manager.
In case of paper jamming.	<ul style="list-style-type: none"> • If there is no paper in the printer, fill the paper. If the paper is jammed, remove the paper jam. • If the paper gets wet, replace or dry it. Use only the paper provided or recommended by manufacturer.

A. Firmware update

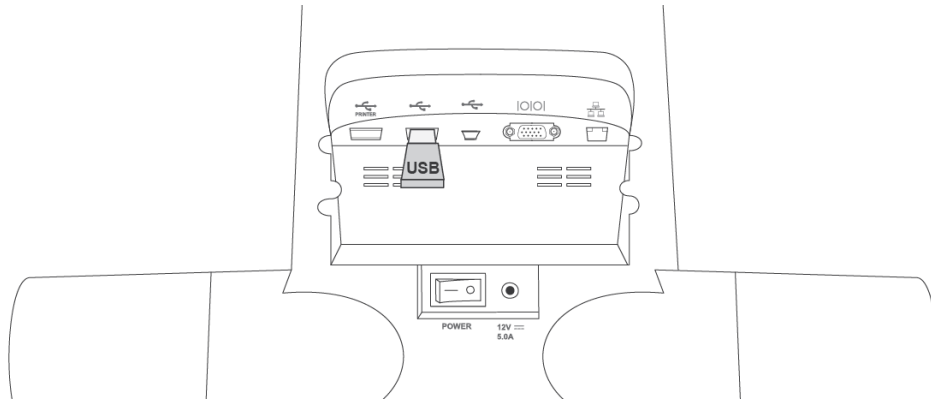

Firmware update process is as follows.

- ① Insert the USB memory which the update file is stored to the USB slot(**right side**) located at the back of the device.
Update file must be saved in the Root folder (**F:WUpdate**) of USB memory.
- ② Enter the Firmware Update menu.

MENU	(Enter administrator password) - [Maintenance] -	FW Version Check	-	FW Update
------	--	------------------	---	-----------
- ③ Press the Update button (WM FW Update / BIA FW Update / Application Update) of the firmware that needs updating.
- ④ When updating the WM and BIA firmware, the device will not restart. However, when updating the application, the device will restart automatically after the update is completed.
- ⑤ Do not remove the USB during the update process.

CAUTION

- If the USB is removed or the device is turned off while the firmware update is in progress, it may cause serious damage to the device. (C0019)

B. Printer Module update

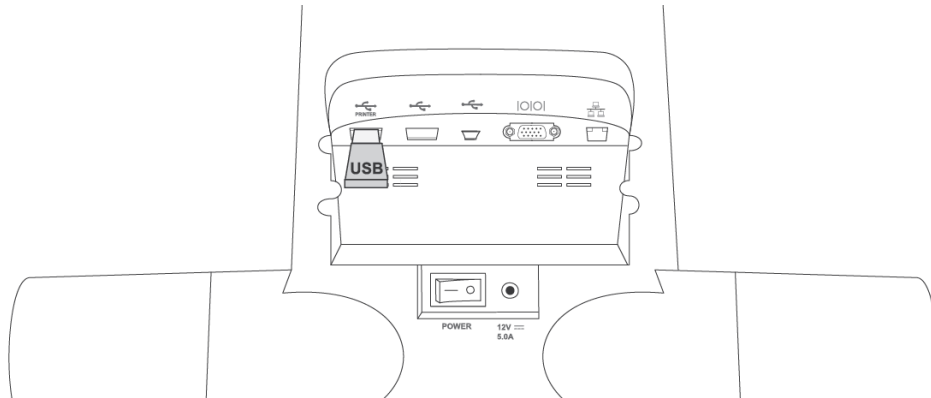

Firmware update process is as follows.

- ① Insert the USB memory which the update file is stored to the USB slot(**left side**) located at the back of the device.
Update file must be saved in the Root folder (**F:WPMUpdate**) of USB memory.
- ② Enter the Firmware Update menu.
MENU (Enter administrator password) - [Maintenance] - FW Version Check - **FW Update**
- ③ Press the Update button (PRN FW Update) of the firmware that needs updating.
- ④ Do not remove the USB during the update process.

CAUTION

- If the USB is removed or the device is turned off while the firmware update is in progress, it may cause serious damage to the device. (C0019)

4.3. Recycling and disposal

If the product has reached its life expectancy, it should be disposed of properly according to local disposal policies.



- Proper disposal can prevent harmful effects on the environment and health. For more information, contact local authority, waste center, or purchase place. (N0021)



CAUTION

- If you want to recycle or dispose of internal parts of the product, follow disposal/recycle regulations. (C0020)
- Delete user ID and personal information before disposal to prevent information leakage. (C0021)

4.4. Product return

If damage of equipment or component is discovered after receiving product, stop opening and immediately contact local dealer or service center. Send main product body together with other component in the packing box. Without the provided packing box, use a suitable carton box to protect equipment during shipment. Ship the product according to the instruction provided by manufacturer.



CAUTION

- Don't use damaged equipment. Contact local dealer or our service center. (C0022)

4.5. Transportation and Storage

○ Shipping Precautions

For safe transport, at least two people should move the equipment horizontally, parallel to the ground.

○ Repacking instructions

When moving the equipment, repack it according to the following sequence.

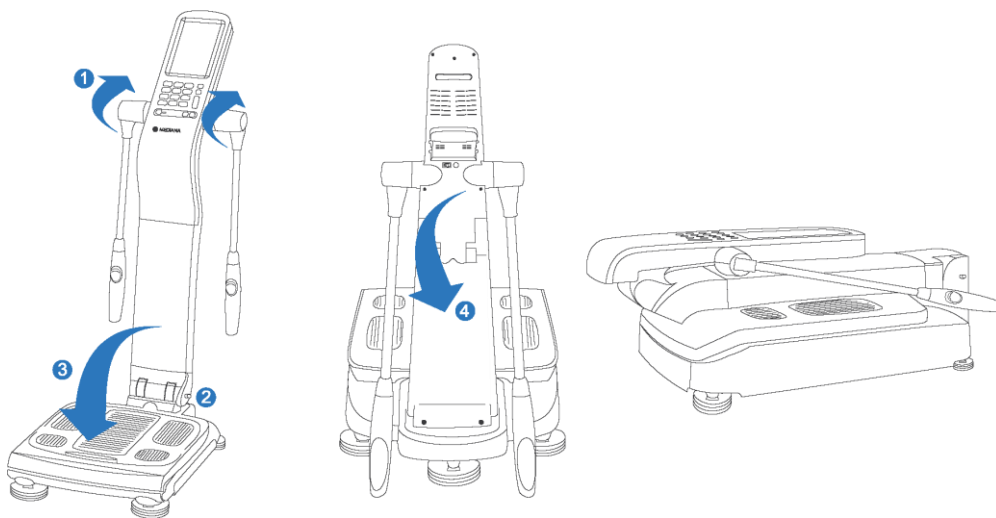

- ① Turn off and separate the adapter and cables from the equipment.
- ② Fold the upper and lower joints with the button of the lower body pressed.
- ③ Wrap the product with protective packing materials and put it in the box.
- ③ Put the accessory including adapter and cable in the box and seal them.

CAUTION

- When folding the joints, take care not to pinch your body. (C0027)

○ **Transportation and storage environment**

The shipping and storage environment of this product is as follows.

Proper temperature	-10~60°C
Relative humidity	10~80% (Noncondensing)
Titration pressure	50~101.3kPa

4.6. Maintenance

Do not pour any liquid substances on the product. If it occurs, wipe and dry it up completely before use. If safe use of the equipment cannot be ensured, stop using it and contact service center for proper inspection.



WARNING

- Don't spill or pour water on the product body, accessory, connector, switch and case. (W0023)

○ **Equipment Cleaning**

Use soft cloth to wipe off the surface and electrodes. Wipe it clean with a detergent-soaked cloth. In the joints, be careful not to get any foreign objects and wipe off the dust with soft cloth.



WARNING

- Before cleaning product, press the power button to shut down and unplug the power cord. (W0024)



CAUTION

- Do not use acetone, ammonia, alcohol, or bleach for cleaning purpose. It may cause damage to the surface of device. (C0023)
- Use a dry towel to wipe off electrode parts. Use of strong chemicals for cleaning may lead to corrosion issues, thus causing inaccurate data control. (C0024)

4.7. Regular safety check

For safe use, please check following list on a daily basis.

- Check for physical damage on surface of device, hand/foot electrodes, power cord and adapter.
- Check the connection of power cable and the connection of DC jack of adapter.
- Check the plate part of hand/foot electrodes to see if there is any physical damage or dirt.

In order to maintain measurement performance, please check following list every year.

- Functional Check

- Do the hand electrodes have loose joints, or do you experience any inconvenience while using them?
- Has the surface of hand electrode roughened? Is there any physical damage on it?
- Do you experience any inconvenience with the brightness of LCD and speaker volume?

- Measurement Result Paper Check

- Result graph lines and texts are in clear black without missing words.
- When you print result sheet, do you have any printer misalignment issues?
- Is there any measurement error found on the measurement result sheet?

- If any improper operation issues occur, please contact manufacturer or local agency.

5. Specifications

Electrode Type	Tetra-polar electrode method using 8 point electrodes
Measurement Method	Segmental measurement using Multi frequency
Power	DC Adaptor (input: 100-240VAC, 50-60Hz, 1.5A(1.5-0.7A), Output: 12V, 5.0A)
Measurement & Analysis Items [General result]	<ul style="list-style-type: none"> • Body Composition Analysis: Total Body Water, Muscle Mass, Fat Mass, Fat Free Mass, Protein, Mineral, Skeletal Muscle • Muscle & Body Fat Analysis: Weight, Muscle Mass, Body Fat(%) Assessment with previous result • Segmental Analysis: Segmental Muscle, Fat and Body Balance Assessment • Body Type Analysis : Body Type Table, Body Type Graph Assessment with previous result • Body Composition History : History Graph for Weight, Muscle Mass and Body Fat • Weight Control: BMI, Obesity Degree, Desirable Weight, Weight/Body Fat/Muscle Mass Control • Visceral Fat & Abdominal Fat Ratio Assessment • Intake & Consumed Calories : Basal Metabolic Rate, Total Energy Expenditure, Calorie Consumption, Expected Fat Burning • Mediana Score, Segmental Weight and Impedance, Calorie Consumption table per Exercise
Measurement & Analysis Items [Children result]	<ul style="list-style-type: none"> • Body Composition Analysis: Total Body Water, Muscle Mass, Fat Mass, Fat Free Mass, Protein, Mineral, Skeletal Muscle • Muscle & Body Fat Analysis: Weight, Muscle Mass, Body Fat(%) Assessment with previous result • Growth Chart : Height and Weight with 18 years old Predicted Value • Body Composition History : History Graph for Weight, Muscle Mass, Body Fat, Height and Mineral • Weight Control: BMI, Obesity Degree, Desirable Weight, Weight/Fat/Muscle Mass Control • Growth Evaluation : Muscle, Skeletal, Obesity Evaluation • Body Balance : Upper and Lower Body balance Analysis • Mediana Score, Segmental Muscle and Impedance
Measurement Frequency	5, 50, 100kHz
Measurement Current	200uArms
Measuring range	10 ~ 1000Ω
Measured weight	2.0~250.0 kg (Resolution 50g)
Range of height	60.0~220.0 cm
Input interface	Keypad, Touch Screen, Barcode reader
Addition Function	Data Backup and Restore to USB, and DB export to CSV file
Supported printer	Laser Printer that Mediana recommended
External interface	RS232C(9Pin Serial) 1ea, USB(type A) 2ea, Mini-USB(type B) 1ea, LAN 1ea, Bluetooth(Optional), Wi-Fi(Optional)
Measurement Time	About 30 sec.
Age of Use	3~99 years old
Display	7inch(600 x 1024), Color Touch LCD
Dimension	360mm(W) x 559mm(D) x 1077mm(H)
Weight	About 17.5kg
Operating Environment	Temp 10~40°C, Humidity 30~75%, Air pressure 70~101.3 kPa
Storage Environment	Temp -10~60°C, Humidity 10~80%, Air pressure 50~101.3 kPa
Supporting Result Sheet	General Result, Children Result
Measurement mode	Expert Test, Self Test, Classmate, Blind



• Above contents are subject to change without prior notice to improve appearance and performance of the product. (N0022)

6. Manufacturer's EMC Declaration

The **I30** is suitable for use in the specified electromagnetic environment. The customer and/or user of the **I30** should assure that it is used in an electromagnetic environment as described below.

CAUTION

- For best product performance and measurement accuracy, use only accessories supplied or recommended by MEDIANA. Use accessories according to the manufacturer's directions for use and facility's standards. The use of accessories, transducers and cables other than those specified may result in increased emission and/or decreased immunity of the device. (C0025)
- Portable RF communications equipment (including peripherals such as antenna cables and external antennas) should be used no closer than 30 cm (12 inches) to any part of the device, including cables specified by the manufacturer. Otherwise, degradation of the performance of this equipment could result. (C0026)

o Electromagnetic Emissions (IEC60601-1-2)

Emission Test	Compliance	Electromagnetic Environment
RF emission CISPR 11	Group 1	The I30 should emit electromagnetic energy in order to perform its intended function. Nearby electronic equipment may be affected.
RF emissions CISPR 11	Class A	The I30 is suitable for use in all establishments.
Harmonic emissions IEC 61000-3-2	Class A	
Voltage fluctuations/flicker emission IEC 61000-3-3	Complies	

o **Electromagnetic Immunity (IEC60601-1-2)**

Immunity Test	IEC 60601-1-2 Test Level	Compliance Level	Electromagnetic Environment Guidance
Electrostatic discharge (ESD) IEC 61000-4-2	±8 kV contact ±2, 4, 8, 15 kV air	±8 kV contact ±2, 4, 8, 15 kV air	Floor should be wood, concrete, or ceramic tile. If floors are covered with synthetic material, the relative humidity should be at least 30 %.
Electric fast transient/burst IEC 61000-4-4	±2 kV for power supply lines ±1 kV for input/output lines	±2 kV for power supply lines ±1 kV for input/output lines	Mains power quality should be that of a typical commercial and/or hospital environment.
Surge IEC 61000-4-5	(Input Power Ports) ± 0.5, 1 kV differential mode ±0.5, 1, 2 kV common mode (Signal input/output) 2 kV common mode	(Input Power Ports) ± 0.5, 1 kV differential mode ±0.5, 1, 2 kV common mode (Signal input/output) 2 kV common mode	Mains power quality should be that of a typical commercial and/or hospital environment.
Voltage dips, short interruptions and voltage variations on power supply IEC 61000-4-11	Voltage dips >95 % U _T for 0.5 cycle At 0°, 45°, 90°, 135°, 180°, 225°, 270° and 315°	Voltage dips >95 % U _T for 0.5 cycle At 0°, 45°, 90°, 135°, 180°, 225°, 270° and 315°	Mains power quality should be that of a typical commercial and/or hospital environment. If the user of the I30 requires continued operation during power mains interruption, it is recommended that the I30 be powered from an uninterruptible power supply or battery.
	Voltage dips >95 % U _T for 1 cycle At 0°	Voltage dips >95 % U _T for 1 cycle At 0°	
	Voltage dips 30 % U _T for 25/30 cycle At 0°	Voltage dips 30 % U _T for 25/30 cycle At 0°	
	Voltage interruption >95 % U _T for 250/300 cycle At 0°	Voltage interruption >95 % U _T for 250/300 cycle At 0°	
Power frequency (50-60 Hz) magnetic field IEC 61000-4-8	30 A/m	30 A/m	It may be necessary to position the I30 further from the sources of power frequency magnetic fields or to install magnetic shielding. The power frequency magnetic field should be measured in the intended installation location to assure that it is sufficiently low.

Note: U_T is the AC mains voltage prior to application of the test level.

o **Electromagnetic Immunity (IEC60601-1-2)**

Immunity Test	IEC 60601 test level	Compliance Level	Electromagnetic Environment Guidance
The I30 is intended for use in the electromagnetic environment specified below. The customer or the user of the I30 should assure that it is used in such an environment.			

			<p>Portable and mobile RF communications equipment should be used no closer to any part of the I30 including cables, than the recommended separation distance calculated from the equation appropriate to the frequency of the transmitter.</p> <p>Recommended separation distance</p>
Conducted RF IEC 61000-4-6	3 V RMS outside the ISM band	3 Vrms	$d = 1.2\sqrt{n}$
	6 V RMS in the ISM radio bands 150 kHz to 80 MHz	6 Vrms	$d = 1.2\sqrt{n}$
Radiated RF IEC 61000-4-3	3 V/m 80 MHz to 2.7 GHz (80 % AM at 1 KHz) According to IEC60601-1-2:2014	3 V/m	$d = 1.2\sqrt{n}$ 80 MHz to 800 MHz
			$d = 2.3\sqrt{n}$ 800 MHz to 2.7 GHz
			<ul style="list-style-type: none"> • where n is the maximum output power rating of the transmitter in watts (W) according to the transmitter manufacturer and d is the recommended separation distance in meters(m). • Field strengths from fixed RF transmitters as determined by an electromagnetic site survey,^a should be less than the compliance level in each frequency range.^b • Interference may occur in the vicinity of equipment marked with the following symbol:
			

Note: At 80 MHz and 800 MHz, the higher frequency range applies.

Note: These guidelines may not apply in all situations. Electromagnetic propagation is affected by absorption and reflection from structures, objects, and people.

^a Field strengths from fixed transmitters, such as base stations for radio (cellular/cordless) telephones and land mobile radio, AM and FM radio broadcast, and TV broadcast cannot be predicted theoretically with accuracy. To assess the electromagnetic environment due to fixed RF transmitters, an electromagnetic site survey should be considered. If the measured field strength in the location in which the **I30** is used exceeds the applicable RF compliance level above, the **I30** should be observed to verify normal operation. If abnormal performance is observed, additional measures may be necessary, such as re-orienting or relocating the **I30**.

^b Over the frequency range 150 kHz to 80MHz, field strengths should be less than 3 V/m

o **Recommended Separation Distances**

Recommended separation distance between
portable and mobile RF communications equipment and the monitor

The I30 is intended for use in an electromagnetic environment in which radiated RF disturbances are controlled. The customer or the user of the I30 can help prevent electromagnetic interference by maintaining a minimum distance between portable and mobile RF communications equipment (transmitters) and the I30 as recommended below, according to the maximum output power of the communications equipment.

Rated Maximum Output Power of Transmitter in watt	Separation distance according to frequency of transmitter in meter			
	150 kHz to 80MHz outside ISM bands $d = 1.2\sqrt{n}$	150 kHz to 80MHz In ISM bands $d = 2\sqrt{n}$	80 MHz to 800MHz (Test level 10 V/m) $d = 1.2\sqrt{n}$	800 MHz to 2.5GHz (Test level 10 V/m) $d = 2.3\sqrt{n}$
0.01	0.12	0.2	0.12	0.23
0.1	0.38	0.63	0.38	0.73
1	1.2	2	1.2	2.3
10	3.79	6.32	3.79	7.27
100	12	20	12	23

For transmitters rated at a maximum output power not listed above, the recommended separation distance d in meters (m) can be estimated using the equation applicable to the frequency of the transmitter, where n is the maximum output power rating of the transmitter in watts (W) according to the transmitter manufacturer.

Note: At 80MHz and 800MHz, the separation distance for the higher frequency range applies.

Note: These guidelines may not apply in all situations. Electromagnetic propagation is affected by absorption and reflection from structures, objects, and people.

o **Electromagnetic Emissions (IEC60601-1-2)**

Cables and Sensors	Maximum Length	Complies with
Power Cable	1.8 m	<ul style="list-style-type: none"> RF emissions, CISPR 11, Class B/ Group 1 Harmonic emissions, IEC 61000-3-2
Power Supply Cable	1.5 m	<ul style="list-style-type: none"> Voltage fluctuations/flicker emission, IEC 61000-3-3 Electrostatic discharge (ESD), IEC 61000-4-2 Electric fast transient/burst, IEC 61000-4-4
LAN Cable	3.0 m	<ul style="list-style-type: none"> Surge, IEC 61000-4-5 Conducted RF IEC 61000-4-6 Radiated RF, IEC 61000-4-3.

o Immunity to proximity fields from RF wireless communications equipment (IEC60601-1-2)

Test frequency (MHz)	Band ^a (MHz)	Service ^a	Modulation ^b	Maximum power (W)	Distance (m)	Immunity test level (V/m)
385	360 – 390	TETRA 400	Pulse modulation ^b 18 Hz	1.8	0.3	27
450	430 – 470	GMRS 460, FRS 460	FM ^c ± 5 kHz deviation 1 kHz sine	2	0.3	28
710 745 780	704 – 787	LTE Band 13, 17	Pulse modulation ^b 217 Hz	0.2	0.3	9
810 870 930	800 – 960	GSM 800/900, TETRA 800, iDEN 820, CDMA 850, LTE Band 5	Pulse modulation ^b 18 Hz	2	0.3	28
1720 1845 1970	1700 – 1990	GSM 1800; CDMA 1900; GSM 1900; DECT; LTE Band 1, 3, 4, 25; UMTS	Pulse modulation ^b 217 Hz	2	0.3	28
2450	2400 – 2570	Bluetooth, WLAN, 802.11 b/g/n, RFID 2450, LTE Band 7	Pulse modulation ^b 217 Hz	2	0.3	28
5240 5500 5785	5100 – 5800	WLAN 802.11 a/n	Pulse modulation ^b 217 Hz	0.2	0.3	9

NOTE If necessary to achieve the IMMUNITY TEST LEVEL, the distance between the transmitting antenna and the ME EQUIPMENT or ME SYSTEM may be reduced to 1 m. The 1 m test distance is permitted by IEC 61000-4-3.

^a For some services, only the uplink frequencies are included.

^b The carrier shall be modulated using a 50 % duty cycle square wave signal.

^c As an alternative to FM modulation, 50 % pulse modulation at 18 Hz may be used because while it does not represent actual modulation, it would be worst case.