

# RL5416

STAINLESS STEEL  
COMPRESSION CANISTER



**RICE LAKE**<sup>®</sup>  
WEIGHING SYSTEMS

[www.ricelake.com](http://www.ricelake.com)

# RL5416

## STAINLESS STEEL COMPRESSION CANISTER

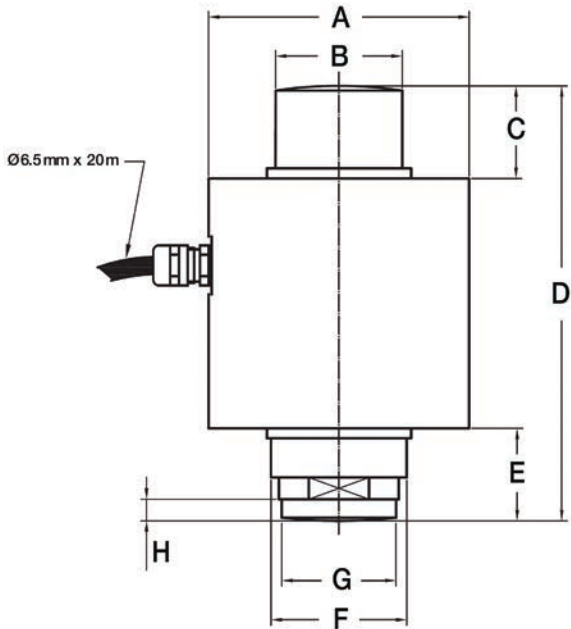

### Dimensions

RATED CAPACITY	A	B	C	D	E	F	G	H
mm								
10-50t	ø89	ø43.8	32	150	32	46.9	39.7	7.5

### Order Information

LOAD RATING	PART #
10 t	168082
15 t	168083
20 t	168084
25 t	168085
30 t	168087
35 t	168088
40 t	168089
50 t	168090

Note: Refer to page 233 for load cell mount information

### Standard Applications

- Truck Scales
- Railroad track scales
- Heavy capacity tanks and hoppers

### Standard Features

- 10 to 50 ton
- Stainless steel construction
- IP69k seal type
- Built-in lightning protection
- Built-in gas charged transient protection

### Specifications

**Full Scale Output:**  
2,0 mV/V

**Output Resistance:**  
700 ohms, ± 3

**Input Resistance:**  
800 ohms, ± 3

**Material Finish:**  
Stainless steel

**Compensated Temperature:**  
-10° C to 40° C

**Operating Temperature:**  
-10° C to 70° C

**Seal Type:**  
IP69K

**Rated Excitation:**  
15V

**Insulation Resistance:**  
>5,000 megohms

**Cable Length:**  
20 m

**Cable Construction:**  
PVC

**Cable Color Code:**

Red .....+ Excitation  
Black.....- Excitation  
Green.....+ Signal  
White.....- Signal  
Yellow.....+ Sense  
Blue.....- Sense

### Warranty

- Two-year limited warranty

### Approvals



R60 Class C4



Optional

Your Rice Lake Weighing Systems distributor is:

**RICE LAKE**  
WEIGHING SYSTEMS

Rice Lake Weighing Systems Europe B.V.  
PO Box 58 NL-6666 ZH • Weiland 11 • NL-6666 MH Heteren • The Netherlands  
TEL: +31 (0)26 472 1319 • FAX: +31 (0) 88 234 9100 • [www.ricelake.com](http://www.ricelake.com)

An ISO 9001 registered company © 2017 Rice Lake Weighing Systems PN 181057 2/17  
Specifications subject to change without notice.