

SERIES SKID
STEER LOADER



SUNWARD

SWL3220 All-powerful small machines with big helpers

◆ Operating weight: 3450kg ◆ Rated operating capacity : 1100kg



- ◆ Strong power, high reliability, low noise, energy saving, and environmental protection.
- ◆ Independent research and development of arc lifting mechanism, simple structure, strong bearing capacity, good reliability.
- ◆ ISO pilot operating mode with easy operation, flexible control and good inching performance.
- ◆ International universal quick-change device with easy switching of cleaning, milling, snow-blowing, and other accessories.
- ◆ Standard bucket floating and automatic leveling function that greatly improves the work efficiency.
- ◆ All-around maintenance space that ensures easy access to the parts to be maintained and facilitates maintenance.



Machine Dimensions			
Boundary dimension(L×W×H)		mm	3736X1830X2068
A	Maximum overall height	mm	4020
B	Height to hinge pin	mm	3123
C	Height to top of cab	mm	2068
D	Height to bottom of level bucket	mm	2948
E	Length without standard bucket	mm	2967
F	Length with bucket	mm	3736
G	Maximum dump angle	°	43
H	Dump height	mm	2395
J	Dump reach	mm	625
K	Rollback angle (bucket on ground)	°	30
L	Rollback angle at maximum height	°	93
M	Wheelbase (Track Gauge)	mm	1148
P	Ground	mm	205
Q	Departure angle	°	26
R	Turning radius from center (Coupler)	mm	1344
S	Turning radius from center (Bucket)	mm	2201
T	Turning radius from center (Machine rear)	mm	1747
U	Bumper overhang behind rear axle	mm	1159
V	Width over tire(Crawler Base)	mm	1475
W	Bucket width	mm	1830

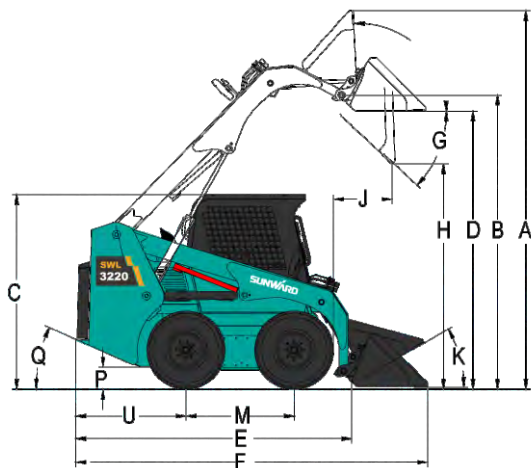

Performance			
Operating weight	kg	3450	
Rated operating capacity	kg	1100	
Tipping load	kg	2200	
Breakout force curl	kg	2480	
Breakout force lift	kg	2430	
Travel speed	kph	12.6	
Engine			
Brand		KUBOTA	YUCHAI
Model		V3307-DI-T	YCF3075-T301
Type		4-cylinder,water-cooled,diesel engine	
Emission level		EU stage III	GB III
Power	kW/rpm	54.6/2600	55.8/2600
Peak torque	N.m/rpm	265/1600	255/1600~2000
Transmission system			
Type		Hydrostatic closed circuit	
Pump		Variable displacement piston pump	
Motor		2XRadial plunger quantitative single speed motor	
Hydraulic system			
Type		Throttling system	
Bump		Gear pump	
Hydraulic flow_Standard Hydraulic flow_High flow	lpm	84/125	
Pressure	bar	210	
Control valve		Three joint multi-way valve	
Control mode		ISO model of pilot control	
Electric system			
Starter	V/kW	12/3.0	12/3.3
Alternator rating	V/A	12/80	14/65
Battery	Ah	120	
Service refill capacities			
Hydraulic tank	L	33	
Fuel tank	L	110	
Traveling system			
Tire		12-16.5	
Track		---	

