

# MODEL RANGE

FH13 6x4 Tractor Air Suspension FH 64T 3A

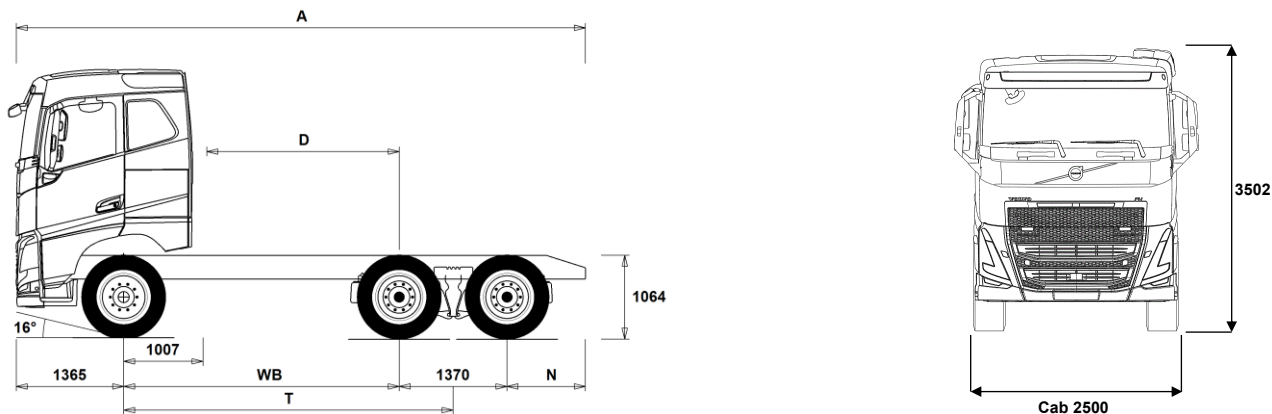

## Chassis Dimensions [mm]

WB Wheelbase	3000	3100	3200	3400
A Overall Chassis Length	6730	6830	6930	7130
D Center of rear axle to back of cab	1943	2043	2143	2343
N Rear Overhang (Min.)	805	805	805	805
N Rear Overhang (Max.)	995	995	995	995
T Theoretical Wheelbase	3685	3785	3885	4085

## Chassis Weights [kg]

Front Axle	4925	4935	4945	4970
Rear Bogie	3755	3750	3750	3750
Kerb Weight	8680	8685	8695	8720

## Turning Diameter [mm]

Turning Circle Diameter Kerb to Kerb	13300	13600	13900	14500
Turning Circle Diameter Wall to Wall	14700	15000	15300	15900

## Plated Weights [kg]

	Plated	Design
Gross Vehicle Weight	23000	28100
Gross Combination Weight	42500	44000
Front Axle	6500	7100
Rear Bogie	16500	21000

## Important Notes

### Chassis Dimensions

Cab Height: +305 mm for CAB-HSLP, -285 mm for CAB-LSLP, +450 mm for CAB-XHES, +450 mm for CAB-XHSL.

Front Axle to Back of Cab: +74 mm for CAB-LSLP, +289 mm for CAB-XHES.

D-measure includes a front clearance of 50 mm and for rigid trucks also a subframe of 100 mm.

Height can vary ± 20 mm for leaf and ± 10 mm for air suspension.

All dimensions are for unladen chassis and any tag axles down. Chassis height used: CHH-HIGH.

Height change when chassis height CHH-MED,FRAME300: 0 mm.

Weight and dimensions are based upon the following tyres:

Front Axle Tyres: 315/80R22.5

Drive Axle Tyres: 315/80R22.5

**Chassis weight includes oil, water, AdBlue, 0 litres fuel and without driver. Kerb weight can vary ± 3%.**

Turning diameters are theoretically calculated.

Legal weights can differ from country to country.

For more detailed weight information, including optional equipment weights, ask your Volvo sales contact to enter your specification into the Volvo Weight Information system (WIS).

Do NOT use this drawing for bodybuilding. Refer to Volvo Bodybuilder Instructions and chassis assembly drawing FH64T3A.

# MODEL RANGE

## FH13 6x4 Tractor Air Suspension FH 64T 3A

### Truck use

- **RC-ROUGH** Operating class on/off road
- **RC-SMOOTH** Well Maintained Surfaced Roads >95% Driving Distance

### Core components

- **CHH-HIGH** Chassis Height High approx. 1025-1050mm (depending on tyre selection)
- **CHH-MED** Approximate chassis height 900 mm
- **RADD-GR** Rear Air Suspension
- **FH-ASLP** AERO - Sleeper Cab
- **FH-AXHES** AERO - Globetrotter XXL Cab
- **FH-AXHSL** AERO - Globetrotter XL Cab
- **FH-LSLP6** Low Sleeper Cab
- **FH-SLP6** Sleeper Cab
- **FH-XHES6** Globetrotter XXL Cab
- **FH-XHSL6** Globetrotter XL Cab
- **EU6HT** Eu6 SCR (Particulate Filter & EGR) Turbo Compound
- **EU6SCR** Eu6 SCR (Particulate Filter & EGR) Single Stage Turbo
- **D13S500A** Eu6 Fuelface 13 litre Engine 500hp/2500Nm/368kW
- **D13S540A** Eu6 Fuelface 13 litre Engine 540hp/2600Nm/397kW
- **D13T500A** Eu6 Fuelface 13 litre Engine 500hp/2800nm/368kW (Turbo Compound)
- **D13K500** Eu6 13 litre Engine 500hp/2500nm/368kW
- **D13K540** Eu6 13 litre Engine 540hp/2600nm/397kW
- **EBR-VEB+** Volvo Engine Brake + (VEB+)
- **AT2612** Volvo I-shift 12 Speed Automatic Transmission (2600nm)
- **ATO3112** Volvo I-shift Automatic Transmission with Overdrive (3150nm)
- **SPO2812** Volvo Dual Clutch I-shift - 12 Speed Semi Power Shift with Overdrive (2800nm)
- **ASO-C** Crawler Gears
- **ASO-ULC** Ultra Low Crawler Gears
- **RVC1** Australian Road Friendly Certification
- **RTH2610B** Volvo RTH2610B hub reduction rear axles  
4 planet gears per hub  
Axle rating: 26,000 kg  
115 tonne train weight  
(Application approved)
- **RTS2310A** Single Reduction Tandem 23t GCW100t
- **RTS2370B** Single Reduction Tandem 23t GCW70t

### Packages

- **OCLHFPTC** Long Haul Optimised Fuel Pack for Turbo Compound (Click Info Icon for Contents)
- **INFOHIGH** High Level Information Platform

### Chassis

- **FST-AIR** Air Bag Front Suspension
- **FST-PAR** Parabolic leaf spring front suspension
- **FST-PAR3** 3 Leaf Parabolic Front Springs (stiffer than normal)
- **FST-PL1** 2 Leaf Parabolic Front Springs - Lightweight Composite Support Leaf (normal stiffness)
- **FSLs-BAS** Front Suspension Levelling Stroke - Standard
- **FAL6.5** Front Axle Load 6.5 tonnes
- **FAL7.1** Front Axle Load 7.1 tonnes
- **FAL7.5** Front Axle Load 7.5 tonnes
- **FALIM** Front axle load limiter
- **FSTAB** Front stabilizer, normal stiffness
- **FSTAB2** Front stabiliser bar increased stiffness
- **FSTAB3** Heavy duty front stabiliser bar
- **RAL17** Rear Axle Load 17 tonnes
- **RAL21** Rear suspension load rating: 21,000 kg
- **RSTAB3** Heavy duty rear stabiliser bar
- **ASF-DL1** Air Susp. Feature - 1 Driving Level
- **ACTST-TO** Volvo Dynamic Steering

- Standard Equipment
- Optional Equipment

For more detailed information about cab and powertrain equipment, please refer to separate specification sheets.

For all possible options and combinations of options please consult your Volvo sales contact who can create a specification to match your requirements using the Volvo Sales Support system (VSS).

The factory reserves the right to modify design and change equipment without previous notification. The specification can vary from country to country.

- **ASFE-PO** Dynamic Steering Active Features - Personal Settings & Oversteer Guidance
- **ASFE-PS** Dynamic Steering Active Features - Personal Settings
- **PSP-FIX** Power Steering Pump with Fixed Displacement
- **PSP-VAR2** Power Steering Pump with Electronic Control Variable Displacement
- **EBS-MED** Electronic Brake System (EBS) contains  
ABS, Traction control, Hill start aid  
Diff lock control, Brake assist  
Wheel brake monitoring, EBS status
- **AUXPARK** Auxiliary parking brake
- **RST-AIR** Rear Air Suspension
- **FRAME300** Frame rail height 300mm
- **FST7070** Frame Section Thickness 7mm
- **FST8080** Frame Section Thickness 8mm
- **FIL-TXEB** Liner (inner) - trans x-mem to end of bogie
- **BBOX-AC** Battery Box - Across Frame
- **BATS-S** Battery system - single
- **2BATT225** 2x225 Ah batteries
- **BATTAMP** Battery Amperage Indicator (in the DID)
- **MSWI-C** Isolation Toggle Switch LHS of Chassis
- **MSWI-R** Isolation Switch on Key Fob (Press Door Lock Twice to Isolate)
- **UR-FUEL** Without RHS Fuel Tank  
Min volume 180l  
Max volume 690l
- **L610A71S** LHS 610 litre Alloy Fuel Tank with Steps  
Min volume 530l  
Max volume 690l
- **ADTP-M** AdBlue Tank Position - Underbelly
- **ADTP-R** AdBlue Tank Position - RHS
- **ADB064** AdBlue Tank 64 litres
- **ADB150** AdBlue Tank 150 litres (Underbelly)
- **ADB190** AdBlue Tank 190 litres (Underbelly)
- **ADTC-BF** AdBlue Tank Cover - Bright Finish
- **FCAP-L** Fuel Tank Cap with Lock
- **ESH-RIGH** Muffler horizontal, right exhaust outlet
- **ESH-VERT** Muffler horizontal, vertical exhaust outlet on right hand side
- **ESH3VERT** Raised Horizontal Muff/Vertical outlet
- **EXST-SSP** Stainless Steel Exhaust Stack
- **TOWF-NO1** One Towing Device - Front
- **TBC-AUS** Trailer Brake Connections - Suzi Coils
- **TRBR-HCR** Hand controlled trailer brake, reduced pressure
- **TRBR-STA** Stationary Trailer Brake Control
- **TRB-STRE** Automatic Trailer Brake Activation (Stretch Brake)
- **RFEND-H2** FH 84T coloured guards need to be added via Free Text CA due to the fact that second steer single guard has to be included as well
- **TL-LED** LED Tail Lights
- **BLIGHT-E** Emergency Brake Lights

### Rims and Tyres

- **RT-AL** 10 Stud Alloy Disc Rims (with long wheel studs)
- **RT-AL1** 10 Stud Alloy Level 1 Disc Rims (with long wheel studs)
- **RT-AL1DU** 10 Stud Alloy Level 1 Disc Rims (with short wheel studs)
- **RT-ALDP** 10 Stud Dura-Bright Alloy Disc Rims (with long wheel studs)
- **RT-ALDPP** 10 Stud Dura-Bright Alloy Disc Rims (with short wheel studs)
- **RT-ALDU** 10 Stud Alloy Disc Rims (with short wheel studs)
- **RT-STEEL** 10 Stud Steel Disc Rims

# MODEL RANGE

## FH13 6x4 Tractor Air Suspension FH 64T 3A

<input type="checkbox"/> <b>SPWT-D</b>	Spare rim & tyre equal to drive	<input type="checkbox"/> <b>DRC-AUTO</b>	DPF Regeneration- Fully Automatic (in motion)
<input type="checkbox"/> <b>SPWT-F</b>	Spare rim & tyre equal to steer	<input checked="" type="checkbox"/> <b>ACCLF-D</b>	Acceleration Limiting Feature - Disabled
<input type="checkbox"/> <b>SWCP-T2</b>	Transport Mounted Spare Wheel	<input checked="" type="checkbox"/> <b>ESP-BAS1</b>	ESP Package (Tractor/Trailer Combinations with ABS/EBS Or Rigid with Standard COG)
<input checked="" type="checkbox"/> <b>JACK-15T</b>	15 tonne capacity jack and brace	<input type="checkbox"/> <b>ESP-BAS2</b>	ESP Package (Tractor/Trailer Combinations without ABS)
<input checked="" type="checkbox"/> <b>TOOL-BAS</b>	Basic tools	<input checked="" type="checkbox"/> <b>HWSS-ACB</b>	ACC & forward collision warning & emergency braking.
<input type="checkbox"/> <b>TOOLKIT</b>	Tool kit complete	<input checked="" type="checkbox"/> <b>LSS-DW</b>	With lane departure system
<input type="checkbox"/> <b>INFLAHOS</b>	Tyre inflation hose (18 metres)	<input type="checkbox"/> <b>LSS-DW3</b>	Pilot Assist - Active Continuous Lane Keeping
<input type="checkbox"/> <b>OBDEP-D</b>		<input type="checkbox"/> <b>LKE-TBO</b>	Lane Keeping with Tyre Blowout
<b>Powertrain equipment</b>		<input checked="" type="checkbox"/> <b>LCS3</b>	LCS with Side Collision Avoidance Support (LHS) & Emergency Braking
<input checked="" type="checkbox"/> <b>TRAP-HD</b>	Heavy Duty Transmission Internals	<input checked="" type="checkbox"/> <b>DAS-W</b>	Driver alert support warning
<input checked="" type="checkbox"/> <b>DRM-BE</b>	Drive Mode - Balanced & Economy	<input type="checkbox"/> <b>DAS-W2</b>	Driver Alert Sensing System (monitoring of vehicle handling & driver attention)
<input type="checkbox"/> <b>DRM-E</b>	Drive Mode - Economy	<input checked="" type="checkbox"/> <b>PB-AUT2</b>	Park Brake Applied Automatically When Driver Leaves Seat
<input type="checkbox"/> <b>PVT-MAP</b>	Map Based Topography Information ( I-See Volvo Connect )	<input type="checkbox"/> <b>RSENS-W</b>	Rain Sensor to Activate Wipers
<input checked="" type="checkbox"/> <b>CRUIS-E</b>	Extended Cruise Control	<input checked="" type="checkbox"/> <b>CU-ECC</b>	Climate controlled air conditioning
<input type="checkbox"/> <b>CRUIS-E5</b>	Extended Cruise Control (I-Torque with Additional Fuel Saving Functions)	<input type="checkbox"/> <b>IGT-BUT</b>	Ignition Type - Push Button
<input type="checkbox"/> <b>AMSO-AUT</b>	Manual gear shift in automatic mode.	<input type="checkbox"/> <b>IMMOBIL</b>	Engine Immobiliser
<input type="checkbox"/> <b>AVO-ENH</b>	AMT Vocational option - enhanced	<input type="checkbox"/> <b>ALARM-B</b>	Anti-theft alarm (cab)
<input type="checkbox"/> <b>APF-ENH</b>	Enhanced I-Shift PTO Functions	<input type="checkbox"/> <b>AUD-EXT</b>	Audio Extended
<input type="checkbox"/> <b>CD43-O</b>	Dual Plate Clutch 430 mm diameter	<input type="checkbox"/> <b>BUPMON</b>	Back-Up Camera
<input checked="" type="checkbox"/> <b>CS43B-O</b>	Volvo 430mm single plate clutch	<input checked="" type="checkbox"/> <b>ISUNS-DS</b>	Interior Side Sunvisor - Driver's Door
<input checked="" type="checkbox"/> <b>TC-MAOH2</b>	High performance transmission cooler	<input type="checkbox"/> <b>ISUNF-RE</b>	Windscreen Interior Sunvisor - Electric
<input checked="" type="checkbox"/> <b>2COM1100</b>	Air Compressor - 1100 litres/minute	<input checked="" type="checkbox"/> <b>ISUNF-RM</b>	Windscreen Interior Sunvisor - Manual
<input checked="" type="checkbox"/> <b>AIRIN-HI</b>	High air intake, roofline position	<input checked="" type="checkbox"/> <b>CSPL-BXD</b>	Centre section dash panel pull out drawer
<input type="checkbox"/> <b>AIRIN-LO</b>	Low air intake, rear of cab position	<input type="checkbox"/> <b>ADFS</b>	2 Din Slots in Front Shelf
<input checked="" type="checkbox"/> <b>ACL1ST-S</b>	Air cleaner with two stage filter element	<input checked="" type="checkbox"/> <b>BUPALARM</b>	Reverse alarm
<input checked="" type="checkbox"/> <b>24A150BL</b>	Alternator - 150 Amp	<input type="checkbox"/> <b>LOADIND</b>	Load indicator, electronic controlled suspension (SUSPL-EC)
<input checked="" type="checkbox"/> <b>24A180BL</b>	Alternator - 180 Amp	<input type="checkbox"/> <b>REMC-MF</b>	Multifunction Wireless Remote Control
<input checked="" type="checkbox"/> <b>PRIM-MAN</b>	Pump Prime - Manual	<input checked="" type="checkbox"/> <b>FIREX25A</b>	Fire Extinguisher - 2.5 kg
<input type="checkbox"/> <b>AF-R</b>	Recirculation heated fuel filter	<input checked="" type="checkbox"/> <b>WRITEPAD</b>	Writing pad
<input checked="" type="checkbox"/> <b>FUEFE2LW</b>	Dual fuel filter, engine mounted with water separator-large	<input checked="" type="checkbox"/> <b>DST-CF5</b>	Fully adjustable driver's comfort seat Air suspension, heated, integrated safety belt
<input type="checkbox"/> <b>PTER-DIN</b>	Power Take Off / splined shaft groove (female) DIN5462.	<input type="checkbox"/> <b>SBD-RED</b>	Red safety belts, pass. & driver seats
<input type="checkbox"/> <b>PTER1400</b>	Rear engine mounted power-take-off with flange SAE 1410	<input checked="" type="checkbox"/> <b>SBPRE-DS</b>	Drivers seat belt pretensioner
<input type="checkbox"/> <b>HPE-F101</b>	F1-101 Hydraulic pump rear engine mounted	<input checked="" type="checkbox"/> <b>PST-BAS1</b>	Basic passenger's seat
<input type="checkbox"/> <b>HPE-F41</b>	F1-41 Hydraulic pump rear engine mounted	<input type="checkbox"/> <b>PST-CF5</b>	Fully adjustable passenger comfort seat Air suspension, heated, safety belt
<input type="checkbox"/> <b>HPE-F51</b>	F1-51 Hydraulic pump rear engine mounted	<input type="checkbox"/> <b>PST-RX1</b>	Passenger relax seat with swivel and tilt
<input type="checkbox"/> <b>HPE-F61</b>	F1-61 Hydraulic pump rear engine mounted	<input type="checkbox"/> <b>SBPRE-PS</b>	Passenger Seatbelt Pretensioner
<input type="checkbox"/> <b>HPE-T53</b>	F2-53/53 twin flow hyd pump rear engine mounted	<input type="checkbox"/> <b>ARMRE-BB</b>	Armrests both sides - driver's & passenger's seat
<input type="checkbox"/> <b>HPE-T70</b>	F2-70/53 twin flow hyd pump rear engine mounted	<input checked="" type="checkbox"/> <b>ARMRE-DB</b>	Armrests both sides - driver's seat
<input type="checkbox"/> <b>HPE-V45</b>	V1-45 variable pump rear engine mounted	<input checked="" type="checkbox"/> <b>ARU-LEA</b>	Seat Armrest Upholstery - Leather
<input type="checkbox"/> <b>HPE-V75</b>	V1-75 variable pump rear engine mounted	<input checked="" type="checkbox"/> <b>GRABHI-B</b>	Instep Grab Handle - Standard
<input type="checkbox"/> <b>PTR-D</b>	Low speed PTO with DIN connection	<input type="checkbox"/> <b>GRABHI-L</b>	Instep Grab Handle - Leather Bound
<input type="checkbox"/> <b>PTR-DH</b>	High speed PTO with DIN connection	<input checked="" type="checkbox"/> <b>FMAT-RUB</b>	Floor Mats - Rubber
<input type="checkbox"/> <b>PTR-DM</b>	Medium speed PTO with DIN connection	<input checked="" type="checkbox"/> <b>LBK80F</b>	Lower Bunk 815mm Wide
<input type="checkbox"/> <b>PTR-F</b>	PTO Flange Connection - Low Speed	<input type="checkbox"/> <b>LBK80FRE</b>	Lower Bunk 815mm Wide - Electrically Reclinable
<input type="checkbox"/> <b>PTR-FH</b>	High speed PTO with flange connection	<input type="checkbox"/> <b>LBK80FRM</b>	Lower Bunk 815mm Wide - Manually Reclinable
<input type="checkbox"/> <b>PTR-FL</b>	Low speed PTO with flange connection	<input checked="" type="checkbox"/> <b>MATL-FI</b>	Spring Mattress Lower Bunk - Firm (100kg +)
<input type="checkbox"/> <b>PTRD-D</b>	PTO 2 DIN Connections - (Front & Rear)	<input type="checkbox"/> <b>MATL-SF</b>	Mattress lower bunk - semi firm
<input type="checkbox"/> <b>PTRD-D1</b>	PTO with 1 DIN + 1 flange connection rear + 1 DIN connection front	<input type="checkbox"/> <b>OLMAT-BA</b>	Mattress overlay - basic
<input type="checkbox"/> <b>PTRD-D2</b>	PTO with 2 flange connection rears + 1 DIN connection front	<input type="checkbox"/> <b>OLMAT-PR</b>	Mattress Overlay - Premium
<input type="checkbox"/> <b>PTRD-F</b>	PTO with 1 flange connection		
<input type="checkbox"/> <b>HPG-F101</b>	F1-101 Hydraulic Pump		
<input type="checkbox"/> <b>HPG-F41</b>	F1-41 Hydraulic Pump		
<input type="checkbox"/> <b>HPG-F61</b>	Parker F1-61 hydraulic pump (transmission mtd)		
<input type="checkbox"/> <b>HPG-F81</b>	F1-81 Hydraulic Pump		
<input type="checkbox"/> <b>STWM-LE</b>	Steering Wheel Material - Leather		
<input type="checkbox"/> <b>DRC-AMI</b>	DPF Regeneration- Auto Initialise/Manual on Demand/Manual Inhibit		

Standard Equipment

Optional Equipment

For more detailed information about cab and powertrain equipment, please refer to separate specification sheets.

For all possible options and combinations of options please consult your Volvo sales contact who can create a specification to match your requirements using the Volvo Sales Support system (VSS).

The factory reserves the right to modify design and change equipment without previous notification. The specification can vary from country to country.

# MODEL RANGE

## FH13 6x4 Tractor Air Suspension FH 64T 3A

<input type="checkbox"/> <b>TBK70AD</b>	Top Bunk 700mm Wide - Foldable & Height Adjustable	<input checked="" type="checkbox"/> <b>HL-CLEAN</b>	Head lamp cleaning system
<input type="checkbox"/> <b>TBK70F</b>	Top Bunk 700mm Wide - Foldable	<input checked="" type="checkbox"/> <b>DRL-LED</b>	V-shaped LED Daytime Running Light
<input type="checkbox"/> <b>SLCP-BAS</b>	Sleeper Control Panel - Standard	<input checked="" type="checkbox"/> <b>DRIVL2</b>	Integrated driving lamps
<input type="checkbox"/> <b>SAFE</b>	Safe box at bed-end	<input type="checkbox"/> <b>UDRIVL</b>	Without Integrated Driving Lights
<input type="checkbox"/> <b>RUS-BAS</b>	Rear Upper Cab Storage - 154 Litres for Sleeper/Globetrotter & 60 Litres for Day Cab	<input checked="" type="checkbox"/> <b>FOGL-WC</b>	Integrated fog lamps
<input type="checkbox"/> <b>RUS-HIG</b>	Rear Upper Cab Storage - 245 Litres	<input type="checkbox"/> <b>CL-STAT</b>	Corner light-static
<input type="checkbox"/> <b>TABLE</b>	Table	<input type="checkbox"/> <b>ASL-RF2</b>	Spotlights Inside Globetrotter Sign Box
<input type="checkbox"/> <b>REFR-RUS</b>	28 Litre Refrigerator in Upper Rear Storage	<input checked="" type="checkbox"/> <b>IDLAMP-A</b>	Identification Lamps - Amber
<input type="checkbox"/> <b>REFRIG</b>	33 Litre Refrigerator Under Lower Bunk	<input type="checkbox"/> <b>BEACON-P</b>	Beacon Light Wire Preparation
<input type="checkbox"/> <b>MICRO-PK</b>	Preparation Kit for Microwave	<input checked="" type="checkbox"/> <b>CABPT-R2</b>	2 cab roof pass throughs, 1 on each side
<input checked="" type="checkbox"/> <b>BOTH-D</b>	Bottle Holder in Driving Area	<input checked="" type="checkbox"/> <b>SPOTP-F</b>	Aux spotlight preparation, 280W maximum
<input type="checkbox"/> <b>BOTH-DL</b>	Bottle Holder in Driving & Resting Areas	<input type="checkbox"/> <b>ROS-ILP</b>	Illuminated Cab Sign Prep Kit
<input type="checkbox"/> <b>BOTH-L</b>	Bottle Holder in Resting Area	<input type="checkbox"/> <b>CSGN-GTR</b>	Globetrotter Decal
<input checked="" type="checkbox"/> <b>SOL12S</b>	12v Outlet in Sleeper Area	<input checked="" type="checkbox"/> <b>HORN-F1S</b>	Single Electric Jericho Air Horn (Behind Grill)
<input checked="" type="checkbox"/> <b>INLI-BAS</b>	Interior night lights	<input type="checkbox"/> <b>HORN-R2S</b>	Chromed air horns, two roof mounted
<input type="checkbox"/> <b>INLI-NL</b>	Interior White & Red (night) Light	<input type="checkbox"/> <b>ANT-CBR</b>	Antenna for CB Radio (Single Antenna)
<input type="checkbox"/> <b>INLI-NLD</b>	Interior light including night light and dimmer function	<input type="checkbox"/> <b>STUC-B</b>	Storage Compartment Under Cab - Both Sides
<input type="checkbox"/> <b>ARL-FLEX</b>	Flexible Reading Lamp (Snake Light)	<b>Superstructure</b>	
<input checked="" type="checkbox"/> <b>RH-ER</b>	Roof Hatch - Electric (Metal Emergency Exit)	<input checked="" type="checkbox"/> <b>5WM-OBLP</b>	5th Wheel L-Profiles
<input type="checkbox"/> <b>RH-ETR</b>	Roof Hatch - Electric (Tinted Glass & Rear Opening)	<input type="checkbox"/> <b>SRWL-PK</b>	Wiring Prep for Chassis Mounted Working Lights - 3 Position Switch
<input type="checkbox"/> <b>VANMIR</b>	Vanity Mirror	<input type="checkbox"/> <b>SWL-PK</b>	Wiring Prep for Chassis Mounted Working Lights - 2 Position Switch
<input type="checkbox"/> <b>AS-FUS</b>	Auxiliary Shelf - Front Upper Storage	<input type="checkbox"/> <b>WL-TA1W</b>	Fifth wheel light
<input type="checkbox"/> <b>INFOT-PK</b>	LCD screen mount - 6kgs max	<input type="checkbox"/> <b>WLC-H2W</b>	2 LED Work Lights - High Mounted
<b>Cab exterior</b>		<input type="checkbox"/> <b>WLC-PKH</b>	Prep Kit for High Mounted Work Lights
<input checked="" type="checkbox"/> <b>EXTL-BAS</b>	Standard Exterior Trim Level	<input checked="" type="checkbox"/> <b>ECBB-HIG</b>	Body Builder Module - Cab Module (14 High/4 Low)
<input type="checkbox"/> <b>EXTL-EN2</b>	Enhanced Exterior Trim Level 2	<input checked="" type="checkbox"/> <b>BBCHAS1</b>	Body Builder Chassis Electrical Interface - 1 x 7 Pin Connector
<input type="checkbox"/> <b>EXTL-ENH</b>	Enhanced exterior trim level.	<input type="checkbox"/> <b>BBCHAS3</b>	Body Builder Chassis Electrical Interface - 3 x 7 Pin Connectors
<input checked="" type="checkbox"/> <b>DGLAS-H</b>	Hardened Door Glass	<input type="checkbox"/> <b>EXSTER</b>	External Steering via Body Builder's Module
<input type="checkbox"/> <b>DGLAS-L</b>	Laminated Door Glass	<input checked="" type="checkbox"/> <b>TD-LED</b>	LED trailer detection sensor
<input checked="" type="checkbox"/> <b>BUMP-B</b>	Bumper - Plastic	<input checked="" type="checkbox"/> <b>AESW2PK</b>	2 Flexible Switches (AUX1 & AUX2) + Additional 4 Flexible Switches
<input type="checkbox"/> <b>BUMP-B2</b>	Bumper - Steel	<input checked="" type="checkbox"/> <b>AUXSW-4</b>	Wiring Prep. for 4 Extra Bodybuilder Switches (switches not included)
<input type="checkbox"/> <b>WILDBAR</b>	Wildbar	<b>Delivery services</b>	
<input type="checkbox"/> <b>BUMP-SP</b>	Bumper spoiler	<input checked="" type="checkbox"/> <b>TGW-4GWL</b>	Telematics Gateway with 4G/LTE & WLAN
<input checked="" type="checkbox"/> <b>BUGNET</b>	Insect Net in Front of Radiator	<input type="checkbox"/> <b>FMS-PK</b>	Fleet Management System Gateway
<input checked="" type="checkbox"/> <b>CTILT-P-E</b>	Electrical Cab Tilt Pump	<input type="checkbox"/> <b>DRUT1</b>	"My Truck" Smartphone App. 1 Year Prepaid
<input type="checkbox"/> <b>FCABS-A</b>	Front Cab Suspension - Air Bellows	<input type="checkbox"/> <b>DRUT2</b>	"My Truck" Smartphone App. 2 Year Prepaid
<input checked="" type="checkbox"/> <b>FCABS-M</b>	Front Cab Suspension - Mechanical Spring	<input type="checkbox"/> <b>DRUT3</b>	"My Truck" Smartphone App. 3 Year Prepaid
<input type="checkbox"/> <b>RCABS-A</b>	Rear Cab Suspension - Air Bellows	<input type="checkbox"/> <b>DRUT4</b>	"My Truck" Smartphone App. 4 Year Prepaid
<input checked="" type="checkbox"/> <b>RCABS-M</b>	Rear Cab Suspension - Mechanical Spring	<input type="checkbox"/> <b>DRUT5</b>	"My Truck" Smartphone App. 5 Year Prepaid
<input checked="" type="checkbox"/> <b>HCC-INEX</b>	Front hatch catch control-manual	<input checked="" type="checkbox"/> <b>TSRS2</b>	Traffic Sign Recognition System
<input type="checkbox"/> <b>MIRCMCP</b>	Camera Monitor System & Blind Spot Camera - Without Exterior Mirrors		
<input type="checkbox"/> <b>MIRCMS</b>	Camera Monitor System - Without Exterior Mirrors		
<input checked="" type="checkbox"/> <b>MIRFLA3</b>	Electrically operated flat mirrors		
<input type="checkbox"/> <b>MIRFLACP</b>	Wide angle and close view mirror both sides		
<input type="checkbox"/> <b>MIRFLACP</b>	Electrically Heated & Operated Flat Glass Mirrors with Front Monitoring Camera on Passenger Side		
<input type="checkbox"/> <b>AMIR-F20</b>	Close view mirror		
<input type="checkbox"/> <b>SUNV-H</b>	Exterior Sunvisor		
<input type="checkbox"/> <b>AD-ROOF</b>	Aero-dynamic roof mounted deflector		
<input type="checkbox"/> <b>AD-SIDEL</b>	Aero-dynamic cab side deflectors		
<input type="checkbox"/> <b>AD-SIDL2</b>	Aerodynamic Cab Side Deflectors - Extensions		
<input type="checkbox"/> <b>GUARD-W</b>	Windscreen Stoneguard		
<input checked="" type="checkbox"/> <b>HL-LED</b>	LED Headlights		
<input type="checkbox"/> <b>HL-LED3</b>	LED Headlights with Adaptive High Beam		

Standard Equipment       Optional Equipment

For more detailed information about cab and powertrain equipment, please refer to separate specification sheets.

For all possible options and combinations of options please consult your Volvo sales contact who can create a specification to match your requirements using the Volvo Sales Support system (VSS).

The factory reserves the right to modify design and change equipment without previous notification. The specification can vary from country to country.

# MODEL RANGE

FH13 6x4 Tractor Air Suspension FH 64T 3A

---

Volvo Trucks. Driving Progress