

IEMEDICAL series Autoclave (class B)

Operation Manual



Content

1、 General Introduction	3
2、 Application Scope	3
3、 Tech. Parameter.....	3
4、 Diagram Specification	4
5、 Installation	4
6、 Control Panel.....	5
7、 Operation	7
8、 Emergency Condition.....	10
9、 Maintenance and Service.....	11
10、 Transportation and Storage.....	12
11、 Notes.....	12
12、 Appendix.....	13

NO.1: The working status display table

NO.2: B&D test method

NO.3: Steam loop

NO.4: Circuit diagram of sterilizer

IEMEDICAL series Autoclave(class B)

1. General Introduction

This Autoclave is a precision instrument specializing in the operation occasion in need of simple, fast and efficient sterilization by the doctor or his/her assistants, and the doctor shall take the responsibility for such work.

This Autoclave is specially designed for the occasions in use of frequent sterilizations. It is equipped with the microprocessor for intelligent control and man-machine interface for convenient operation. With the distinctions in displaying parameter and condition actively, evaluating malfunction automatically, shutting off for self-protection automatically in case of excessive temperature and pressure, this type autoclave is reliable product in sterilizing.

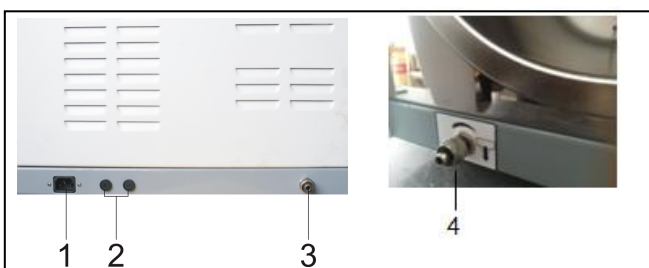

Figure 1

- | | | |
|--------------------------------|----------------------------|----------|
| 1. Power source socket | 2. Fuse | Figure 2 |
| 3. Distilled water drain valve | 4. Waste water drain valve | |

(There have two type location (as the above pic) for the drain valve , please find it out)

2. Application Scope

This product can be applied in sterilizing for the tooth device, operation device, Sanitary Material and other heat-resisting articles existing in the Dept. of Stomatology, Ophthalmology and lab.

3. Tech. Parameter

- Inner chamber of the autoclave (Diameter X Depth) 12L.....200mmX368mm
- Inner chamber of the autoclave (Diameter X Depth) 16L.....240mmX360mm
- Inner chamber of the autoclave (Diameter X Depth) 18L.....245mmX355mm
- Inner chamber of the autoclave (Diameter X Depth) 22L.....245mmX465mm
- Rated Voltage.....220V ± 22V, 50Hz ± 1Hz
-110V ± 11V, 60Hz ± 1Hz
- Rated Power.....1800VA 2000VA
- Sterilizing (Pressure/temp.).....0.9-1.3bar/121° C、2.0-2.3bar/134° C
- (Both of above are Under Standard Atmospheric pressure)
- Fuse-Melting pipe..... T15A T30A
- Capacity of water tank.....2L
- Water Consumption volume per recycling round......0.3L
- Operating Temp.....0-40° C

4. Diagram Specification



Attention and warning



I Sort B model device



Protective Grounding

5. Installation

The clearance between the exterior side surface of the autoclave and the ambient neighboring articles shall be 10cm as retained, and the top surface shall be 20cm retained.

The air-cooling window attached to the exterior surface of the autoclave shall be non-clog by dust or articles, and the autoclave shall be located in the proper air flowing environment by recommendation of the supplier.

Autoclave shall be installed on the horizontal working base. 2pcs front feet can be adjusted the height to ensure the front of machine slightly higher than the back.

PREPARATION BEFORE OPERATION

Before operation, please connect well to the power source. Connect the power source hole under the back left side of the autoclave and the power socket by the attached power cable inside the product's package so as to switch on the autoclave. Push down the main power button at the right bottom corner of the front side, when the indicator light is on, it means that the autoclave get through with the electric power, and the process then is in initialization status with "LD" being shown on the screen. The autoclave is not heated while under such initialization status.

6. Control Panel

1. Air pressure display

Display on time the air pressure inside the cavity. Unit: Bar

2. Temperature display

Display on time the temperature inside the cavity. Unit: °C

3. Status/ malfunction code number display

Applied for displaying kinds of status of the autoclave during it. See more details in "Appendix working status display form".

When alarm occurs to the autoclave, the digital pipe of the display alarm code number, the user can find out the malfunction malfunction occurring to the autoclave, please contact the se distributor immediately).

4. UNWRAPPED button

It's used to the sterilization choice especially for the unwrapped devices. The working temperature is 121°C or 134°C.

After having been chosen, its indicator light is on.

WRAPPED button

It's used to be the sterilization choice especially for the wrapped working temperature is 121°C or 134°C.

After having been chosen, its indicator light is on.

5. COTTON button

It's used to be the sterilization choice especially for the cotton ya working temperature is 121°C.

After having been chosen, its indicator light is on.

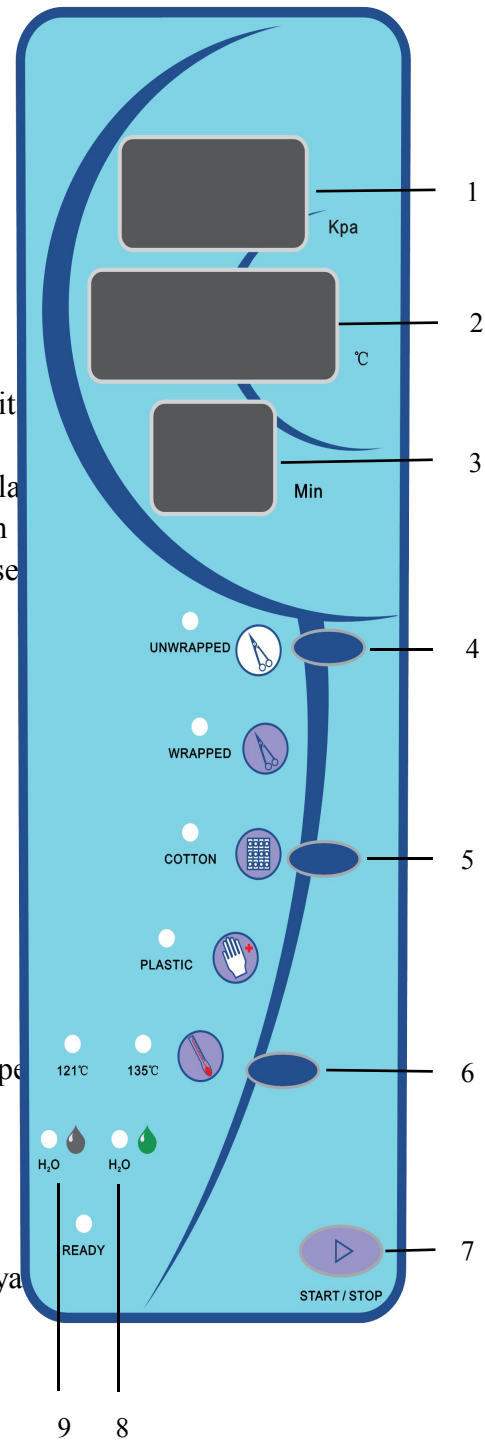

PLASTIC button

It's used to be the sterilization choice especially for the plastic and the rubber devices. The working temperature is 121°C.

After having been chosen, its indicator light is on.

6、 button

It's used to be the choice especially for the working temperature. There are two working temperature for choice: 121°C or 134°C, whose light will on after being chosen.

7、START/STOP button

Press down the Starting button for starting the sterilizing process;

After having been pressed down for 5 seconds, the button will end the sterilizing process.

8、Green light indicator

It's the light indicator for alarming the shortage of water in the water tank and reminding for filling more.

9. Gray light indicator

It's the light indicator for alarming the full of the waste water tank and reminding for drainage.

7. Operation

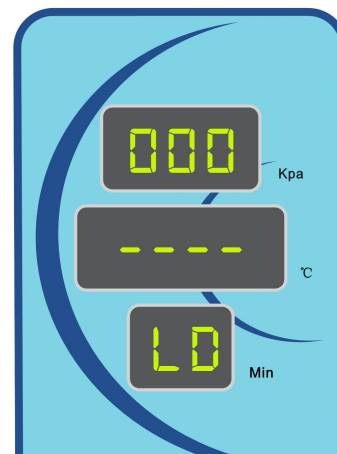

Before operation, please connect well to the power source. Push down the main power button at the right bottom corner of the front side, when the indicator light is on, it means that the autoclave get through with the electric power, and the process then is in initialization status with “LD” being shown on the screen. The autoclave is not heated while under such initialization status. Otherwise, press down the “Start/Stop” button for heating process.

7.1 Water filling

After turning on the power to the autoclave, if the “Green” light indicator is on for warning the low water level to the water tank, the user shall fill more water until the “Green” light indicator off concomitantly with a “du” sound. First time add 1500mL, after the first time, add 1000mL each time when notice the water shortage alert



Note: The distilled water must be used for the tank so as to last the usage life of the autoclave.

1. The autoclave must get through with the power and hold the indicator light to be in pending status before water filling.
2. The maximum volume for one time water filling shall be noted by hearing the “du” sound for reminding water full. It will invalid in the afterward water filling.

Please fill the water tank after seeing the water filling indicator on and hearing the alarm, because there is enough water capable for one more working recycle in order to insure the normal and safe operation of the autoclave.

7.2 Working

We can start the sterilizing work if the light indicators of water shortage and full off.

7.2 (A) Choose the needed procedure for sterilizing and working temperature.



Note: After the selection of procedures for sterilizing, the temperature for sterilizing is settled down as the default value. Please don't amend the default value as the supplier's recommendation unless the occasion for special application.

7.2 (B) Under normal circumstances, if no special requirements need to set the sterilization time. 134 °C sterilization system default time of 4 minutes, 121 °C sterilization time of 20 minutes.

7.2 (C) After selection of the procedure for sterilizing please put the object apparatus to be sterilized into the autoclave.



Note: the object apparatus to be sterilized shall be placed on the device plate with

enough clearance retained in favor of the air circulation inside the sterilizing room. Please put the device plate in the autoclave by the attached hand-support plate in case of scald.

7.2(D) Close the door after putting in the apparatus to be sterilized, and revolve the handle to the maximum position.



Note: Due to the heat air and vapor inside the autoclave room, it's normal if feel a strong resistance force from the door when you close it. Please heavily close the door and revolve the handle to the other end side or close the door after drying the interior water steam so as to close the door comfortably, or push the door little bit toward to the room while revolving the handle as well.

7.2(E) Press down the START/STOP button to start work。 When the “HE” light on, it means the autoclave start its automatic sterilizing process. During the process, you can enjoy the leisure moment brought by its automatic function, or you can pay your attention to other work because autoclave runs automatically during the process of heating, sterilizing and drying, which will spend about 20-35 minutes for the whole process.

The time length of the whole process is determined by the total quantity of apparatus inside the sterilizing room, the initial temperature of autoclave and the sterilizing process the user chooses.



Note: If the door is not completely closed, a “LD” is flashing when press down “START/STOP” button. Please reclose the door otherwise the autoclave can not start work. If the door is opening during working process, the working status display will flash “E6” as alarm and the autoclave will stop working until restart again by switching off the power and dismissing the alarm.

7.2(F) When a ”ED” flash on the status display with warning tone after sterilizing process, you can open the door and take the sterilized apparatus out.



Note: Take out the sterilized apparatus containing in the device plate by the attached hand-support plate in case of scald.

After opening the door of autoclave, the process is reset at “LD” state, which means the autoclave is under heat preservation status and waiting for another sterilizing procedure. Before starting the new sterilizing procedure, the autoclave will always keep in the status of heat preservation.

7.2(G) Please shut off the main power supply when you don't use the autoclave. (The light for power is dead)



Warning: Please don't open the door when the pressure indicator doesn't show "0".
During each time's sterilizing process, the supplier recommends to put the special sterilizing paper or bags marked by the sterilizing effect instruction into the room together with the object apparatus for insuring the liability of the sterilization effect.

8. Emergency Condition

During the running time, the autoclave will automatically raise the alarm, release pressure, stop heating and display the warning code(The definition of the warning code is as the below table: malfunction code and resolving method)for ensuring the safety of the operator if the emergencies occur.

Any emergencies happen, please check the warning code table for resolving the according malfunctions. If not possible to resolve, please contact the dealers. We will try our best to provide help to you in short time.

Malfunction code and resolving measures

Number	Code displayed	Alarm Tone	Malfunction content	Resolving Measures
0	E0	long "du"	Autoclave is not rectified	Rectify the Autoclave by the technician
1	E1	long "du"	Temperature sensor test in wrong	Inspecting temperature sensor by the technician
2	E2	long "du"	Excessive Pressure	Inspecting presser sensor by the technician
3	E3	long "du"	Excessive Temperature	Inspecting inner and outer temperature sensor by the technician
4	E4	long "du"	Pressure can't be released	Inspect the exhaust electromagnetic valve by

				the technician.
5	E5	long "du"	The switch of door is open during running time	Check the door handle for ensuring it reach the terminal, press down "Start/Stop" button for ensuring resolved.
6	E6	long "du"	Fail of pressure rising	Check the inlet pipe and steam leaking
7	E7	long "du"	Fail of pressure rising	Check the inlet pipe and steam leaking

9. Maintenance and Service

9.1 Sterilize the pure water tank by medical disinfectant on time weekly.

9.2 Disinfect and clean the interior surface of the autoclave room on time monthly.

9.3 Replace the core of the melter.

(1) Shut off the power

(2) Revolve the fuse base by counter-clockwise by screwdriver to bring out the melting fuse to be replaced;

(3) Replace the new fuse and reset the fuse base on the original position, then use the screwdriver to fasten the base by clockwise.

(4) Check the correctness of the parameter of the new fuse replaced.

9.4 Clean the sealing ring periodically

The user shall clean the sealing ring periodically for avoiding the influence to the seal caused by the dust/dirt left due to the long period use. Use the smooth cloth with distilled water to wipe the surface of the sealing ring or sealing cap gently. The user shall discharge the sealing ring for further cleaning or replacement if the air-leaking problem can not be resolved after the above process (The user shall discharge the sealing ring periodically for cleaning and inspection as recommendation by the supplier).

9.5 The replacement work for sealing ring



Tool: One flat screwdriver (No sharp edge at the head)

- A. One hand catches the lip of the sealing ring, the other hand insert the screwdriver into the clearance between the sealing ring and the door for raise up the sealing ring.
 - B. After raising up part of the ring, you can use hand to draw the whole ring out. Wash its groove after drawing out the ring and pay attention to see whether it's spoiled or not in consideration of the necessity of replacement.
 - C. Put back the ring to the original door groove after cleaning. Most Important: the inset work must be done equably to the groove During the installation, the laid four equal points of the ring must be inserted to the groove firstly, later for the same work for the remaining segments of the ring. After finishing, press the sealing ring equally by the force of hand.
 - D. Note: The inner circle of the ring may be raised up when insert the ring into the groove. Please press it to the groove by using the screwdriver carefully.
- Shut off the power and cooling the autoclave sufficiently before inserting the ring for avoiding scald.

9.6 Shut off the power before service or components' replacement, and the service or replacement work shall be done by the supplier or his designated technician.

10. Transportation and Storage

10.1 The preparatory work before transportation and storage

Shut off the power, draw out the plug and cool the autoclave down.

10.2 Drainage

Empty the water storing tank and the cooling water collecting tank; The terminal side of the attached pipe with no connecting joint shall be inserted into the water exiting joint pipe. Revolving the water exit button by anticlockwise direction so as to release the water.

10.3 The autoclave shall be transferred and stored with the below conditions:

Ambiance temperature: -40°C -+55°C

Relative humidity: \leq 85%

Atmospheric pressure: 500HPA-1060HPA



Note: Don't drag or drop during transportation.

11. Attention

1. The autoclave must be placed on the horizontal working base.
2. Must use the distilled water for the purpose of lasting the working life.
3. There shall be no clog to the air cooling window on the outer surface.

4. The object apparatus to be sterilized shall be placed on the device plate with enough clearance retained in favor of the air circulation inside the sterilizing room.
5. Empty the water inside the cooling water collecting tank frequently. Usually, the cooling water collecting tank shall be emptied once the water storing tank emptied.
6. Must revolve the door handle to the terminal side while working.
7. Don't open the door of autoclave when seeing the "0" displayed on the pressure indicator.
8. Not be too closed to the door of the autoclave in case of scald when open the door.
9. Shut off the power before discharging/installing the sealing ring, and the work shall be carried out after further sufficient cooling in case of scald.
10. Don't drag or drop the autoclave during relocation period of the autoclave.
11. The protecting ground shall be reliable.
12. Equipment must be used away from the magnetic field.
13. Equipment life end, dealing with to local environmental protection laws and regulations

12. APPENDIX

NO.1: The working status display table:

No	Digital display	Working status name	Working status specification
1	Ld	Prepare/preheating status	In this status, the sterilization readiness work is undertaken by the autoclave.
2	He	Heating status	In this status, the autoclave is increasing heat and pressure.
3	-P	Vacuuming status	In this status, the autoclave is starting the pre-vacuum or triple vacuum.
4	Show the working time	Sterilizing status	In this status. the working time and the count down figure are displayed
5	PL	Drying status	In this status, the autoclave dries on the object apparatus inside the room.
6	Ed	Working over	In this status, the process is ended and the door can be opened.

7	Show the malfunction code	Malfunction status	This status show the malfunction code.
---	---------------------------	--------------------	--

NO. 2 "B&D" test methods

Turn on the power then put the test material into the chamber, select the first program "UNWRAPPED" key, then press "UNWRAPPED" button for 10 seconds, until the four program lights on, close the door, press the start button. Until the third display windows "ED", end of the test.

NO.3: Steam Loop

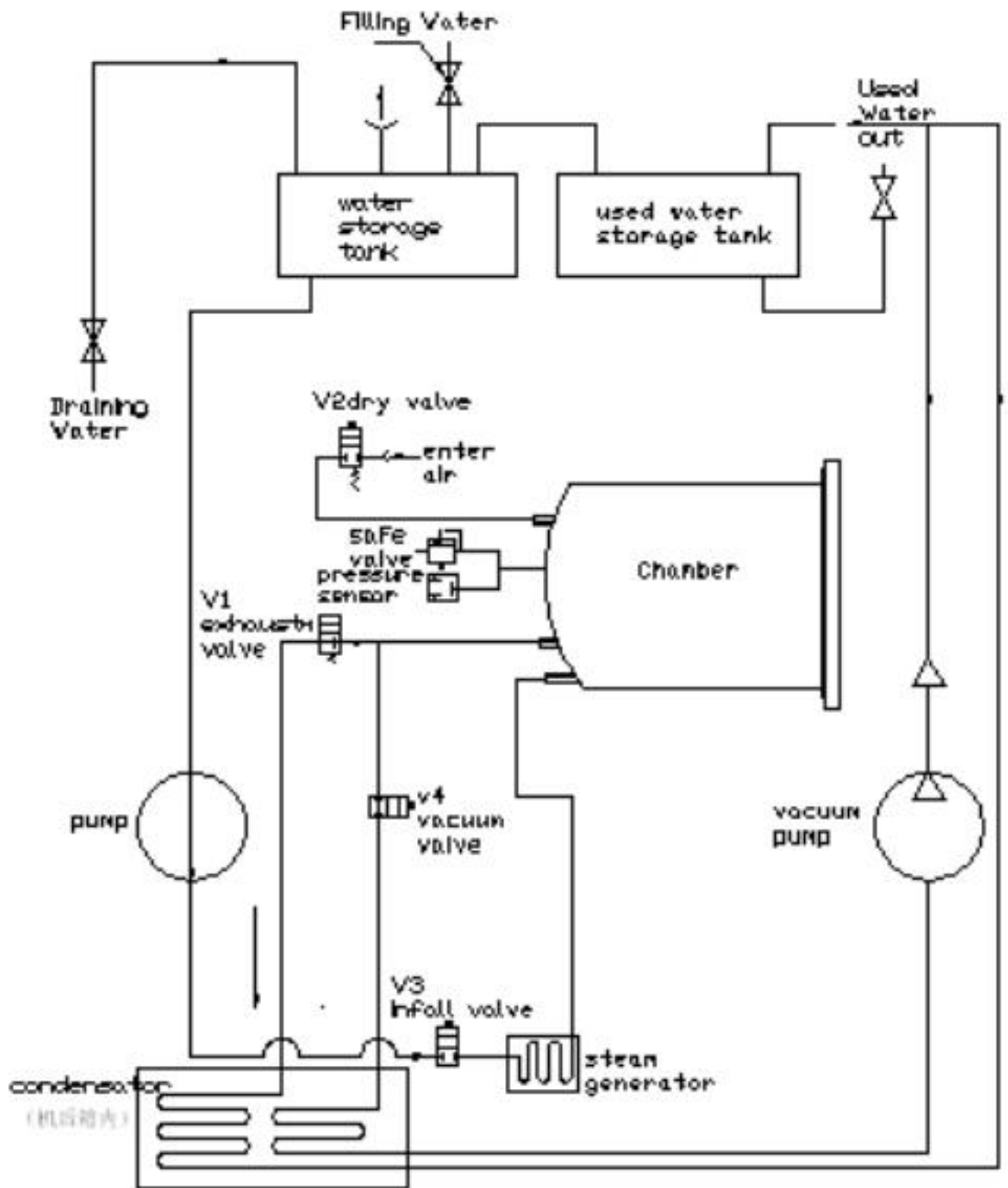

NO.4: Circuit diagram of sterilizer

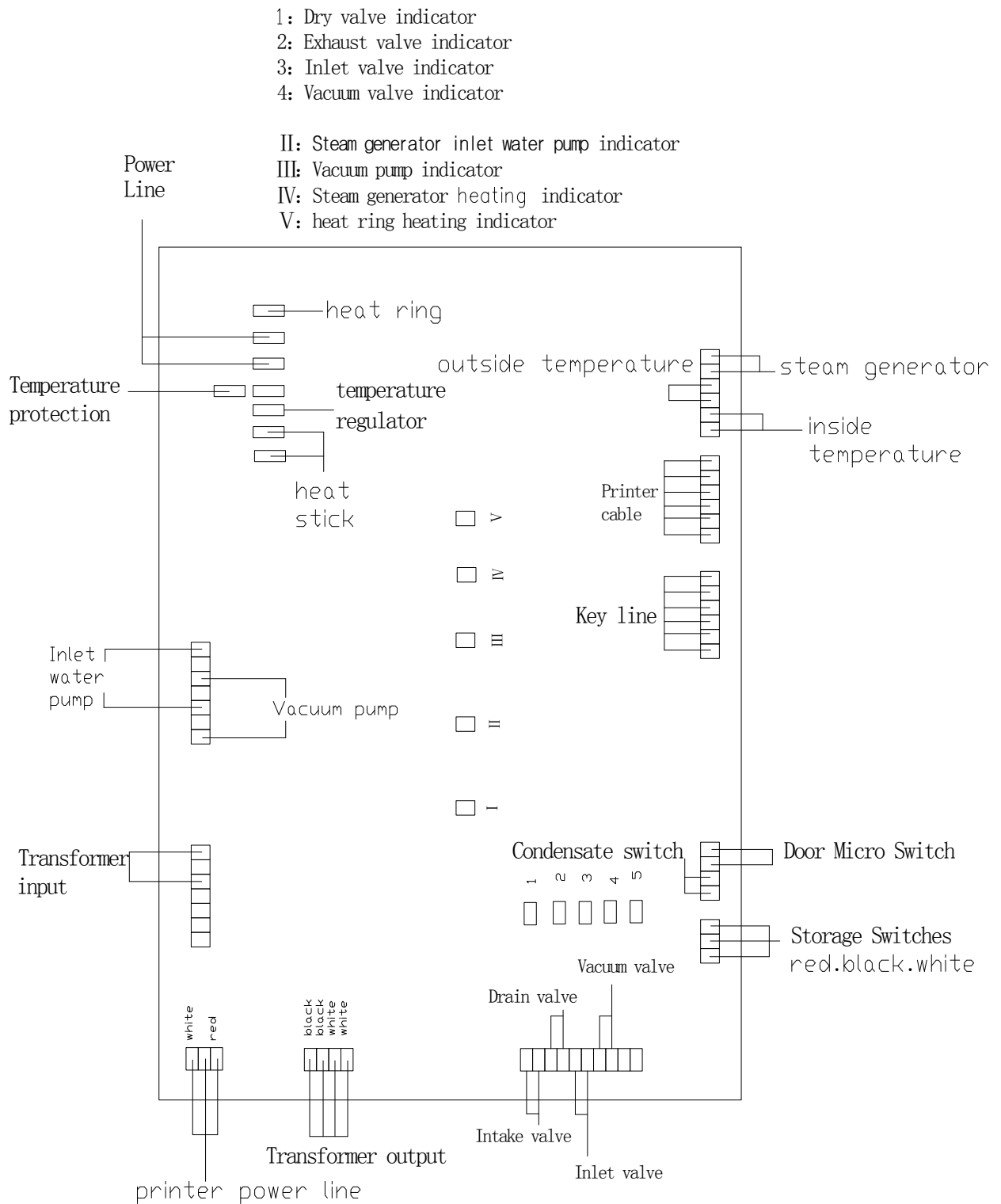

No.5 Workflow graph

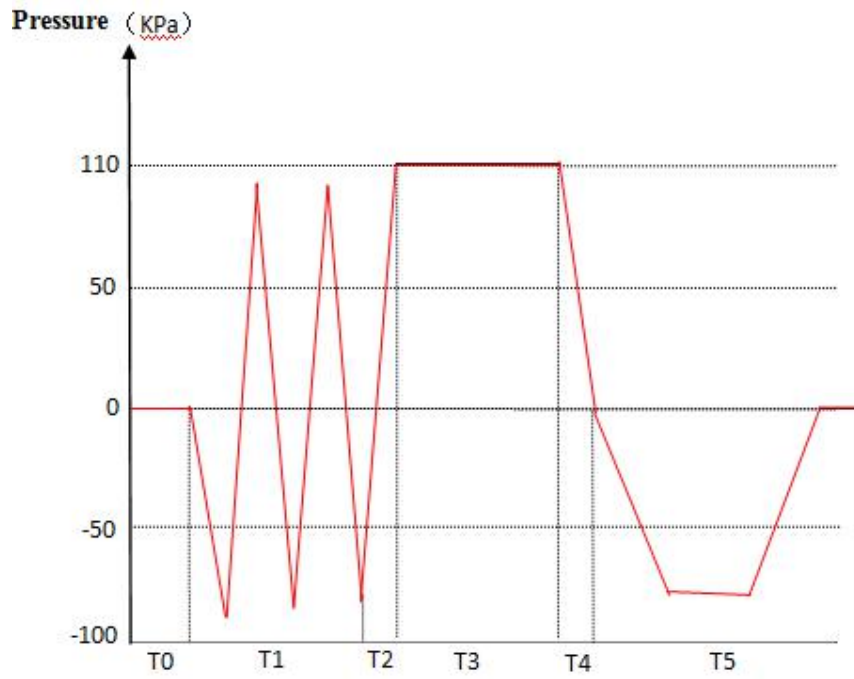

121 Degree working temperature

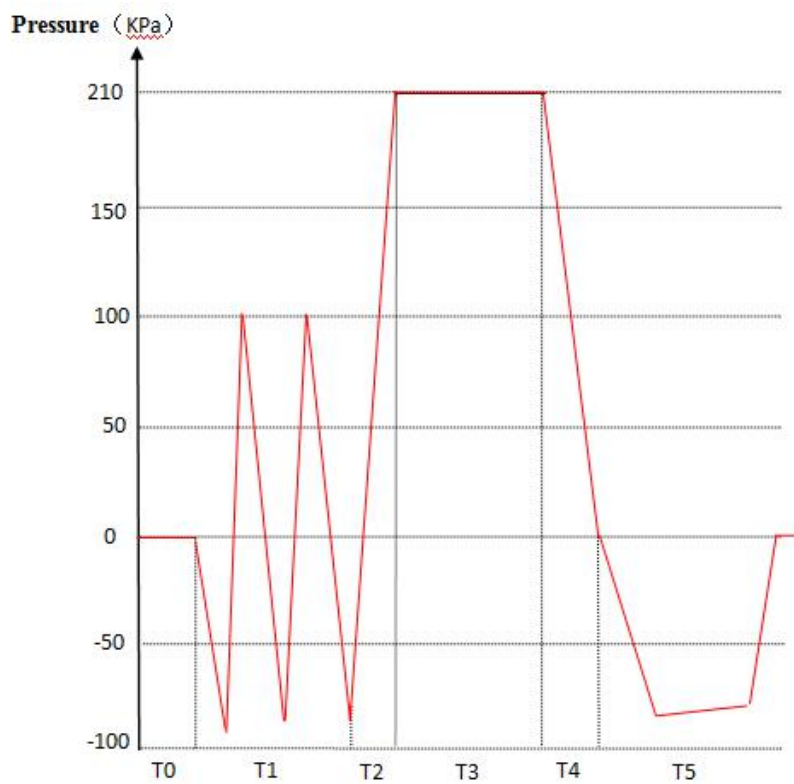

134 Degree working temperature

T0--warm T1-- Pulsating vacuum T2--Temperature and pressure increasing)
 T3-- Sterilization T4--exhaust T5-- dry