

# XE13SE MINI EXCAVATOR



## MINI EXCAVATOR



- ☆ Engine: Koop diesel hydraulic oil cooling
- ☆ TOPS and FOPS certified canopy
- ☆ Easy access to engine gas strut hood
- ☆ Swing boom/arm, Extendable tracks
- ☆ Large ranges of attachments available

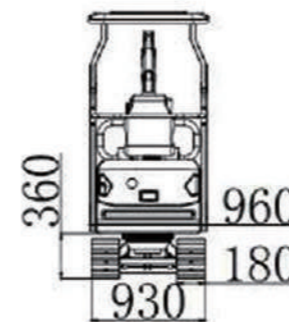
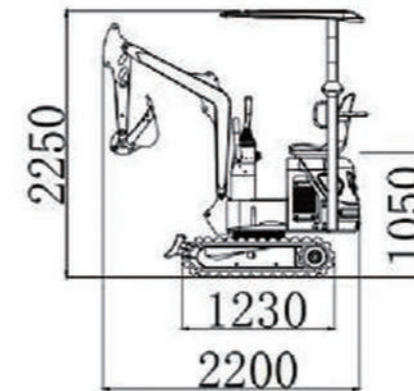
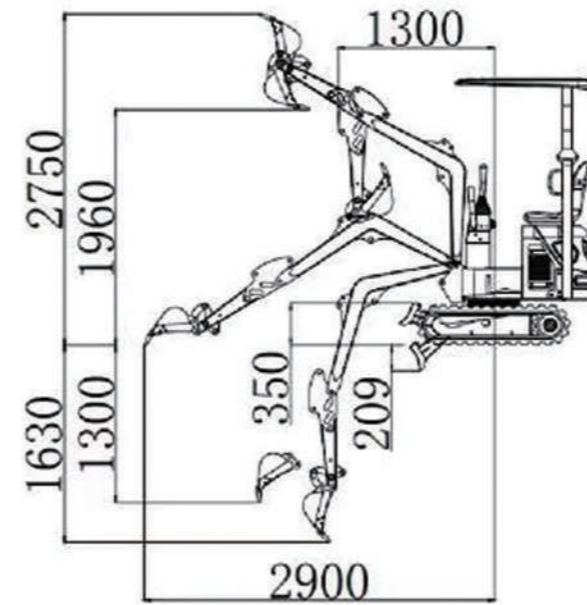

| Model/Specifications             |          | XE13SE   |
|----------------------------------|----------|----------|
| Operation Weight(kg)             | 1000     | 1200     |
| Bucket capacity(m <sup>3</sup> ) | 0.028    | 0.028    |
| Engine model                     | KOOP     | KOOP     |
| Engine power(Kw/Hp)              | 8.6/11.7 | 8.6/11.7 |
| System pressure(Mpa)             | 16       | 16       |
| Swing speed(rmp)                 | 11       | 11       |
| Maximum climbing angle           | 35°      | 35°      |
| Walking speed                    | 2km/h    | 2km/h    |
| Hydraulic oil tank volume        | 18L      | 18L      |
| Fuel tank volume                 | 10L      | 10L      |

| Dimensions             |               |               |
|------------------------|---------------|---------------|
| Dimensions             | 2770X870X2150 | 2770X870X2150 |
| Swing Boom/Arm         | /             | Yes           |
| Total track length     | 1230mm        | 1230mm        |
| Expandable Track       | /             | Yes           |
| Track Adjustable Width | 930           | 930-1150      |
| Width of track         | 180mm         | 180mm         |
| Track material         | Rubber track  | Rubber track  |

| Working Range                    |        |        |
|----------------------------------|--------|--------|
| Max. digging radius              | 2900mm | 2900mm |
| Max. digging depth               | 1650mm | 1650mm |
| Max. digging height              | 2750mm | 2750mm |
| Max. dumping height              | 1960mm | 1960mm |
| Max. digging distance            | 2900mm | 2900mm |
| Min. gyration radius             | 1300mm | 1300mm |
| Max. lifting height of bulldozer | 180 mm | 180 mm |
| Blade maximum digging depth      | 210 mm | 210 mm |
| Width of chassis                 | 930mm  | 930mm  |
| Platform ground clearance        | 375mm  | 375mm  |

MXG Machinery assume no responsibility or liability for any errors or omissions in the content of this brochure. Specifications from the manufacturer are subject to change without notice. Refer to our sales team for model details at time of purchase.

☎ 0401 347 788

☎ 03 8900 2987

✉ Info@mxg.com.au

🌐 www.mxg.com.au

📍 Melbourne Branch: 10-14 Citrus St, Braeside VIC 3195

📍 Brisbane Branch: 15-19 Elliott Court Hillcrest QLD 4118