

STANDARD PALLET JACK / 2.5T

685MM WIDE

These industrial pallet jacks are built for long lasting performance and can lift to 2500kg, helping you to transport the widest variety of loads in stores, warehouses and construction sites.

Features

- Strong torsion-resistant steel construction.
- For use with standard size pallets.
- Comes with standard 6204 bearings.
- Lead in/Lead-out rollers under the fork tips enabling pallets to be entered with ease.
- No routine maintenance required on the hydraulic unit and bearings.
- Powder coated safety yellow for hi visibility and extra protection from wear and tear.
- The option of nylon or polyurethane wheels.
- Pressure relief valve/ overload valve so the unit cannot be overloaded for OH&S purposes.
- Nylon wheels: are mainly used on concrete and hard surfaces, they give you the less amount of push and pull force needed to move a pallet jack with a load.



Specifications

Model		MPT2500
Capacity	(kg)	2500
Min Fork Height	(mm)	75
Max Fork Height	(mm)	190
Fork Width	(mm)	160
Fork Overall Width	(mm)	685
Fork Length	(mm)	1150
Overall Size L x W x H	(mm)	1540x685x1230
Load Roller (dia x width)	(mm)	80x92
Steering Wheel (dia x width)	(mm)	180x50
Net Weight	(kg)	70

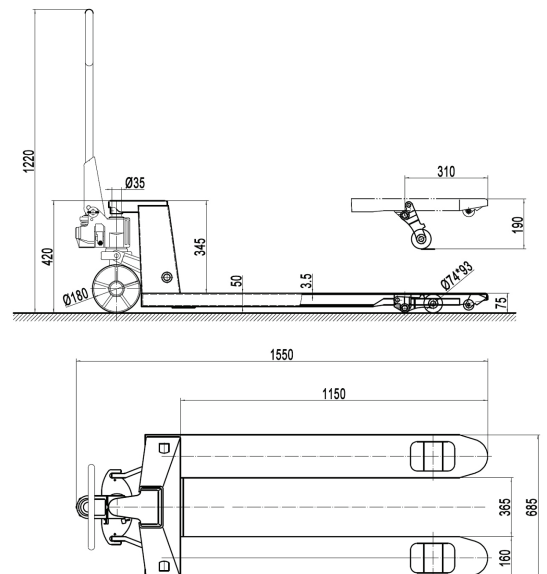

Visit www.mitaco.com.au for more photos and details

Mitaco has national sales and distribution capabilities, our sales office and warehouse is located in Brisbane. Large inventory holdings enable fast-track dispatch of stock orders. This combined with an easy to use online ordering system makes the delivery of stocked products simple, fast and reliable.