

# MIXING STATION

## MS-150 6 BAG MIXING STATION

### LIGHTWEIGHT, EFFICIENT & RELIABLE

MS-150 is the ultimate mixing station for all self-levelling cement and compounds, producing a perfect mix every time. Designed by contractors for contractors it provides efficient hands-free mixing and fast precision pouring of materials saving time and effort on jobs.

An MS-150 mixing station can mix up to 160kgs (6 x 20kg bags plus water) in 7 minutes. The MS-150 is ultra-lightweight for easy transportation and the ergonomic design with easy-tilt operation provides control and speed for precision pouring.

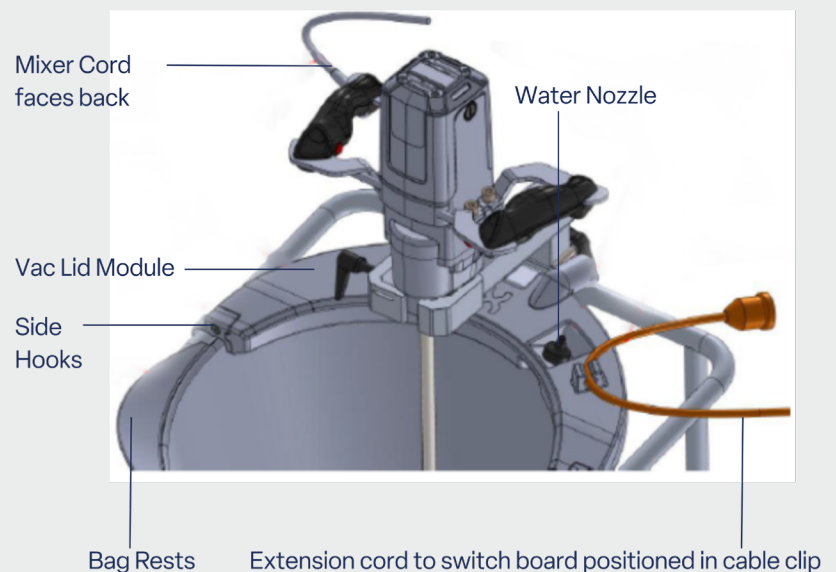
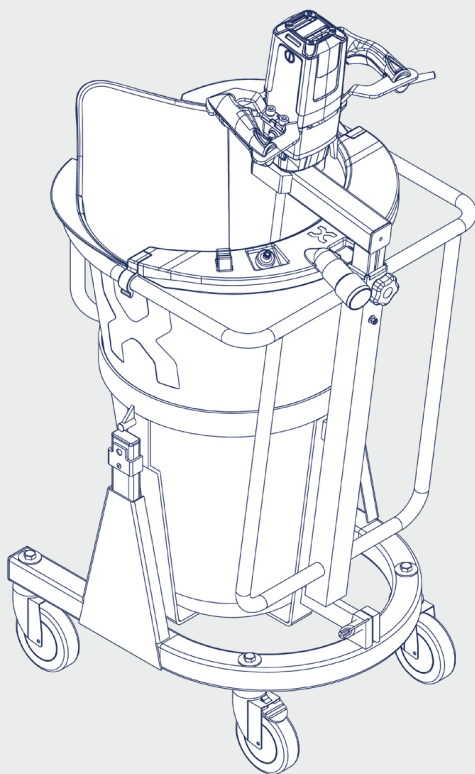

#### Key features include:

- Braked castor wheels
- 4-bag & 6-bag helix paddles included
- Over current, over heating protection
- Mixes up to 160kg
- Ultra lightweight with ergonomic design
- 2-speed gearbox with variable speed controller & lock-on switch