

Technical sheet :

MLT-X 741 - 140 V+



| Capacities | | Metric |
|---|-----|--|
| Max. capacity | Q | 4100 kg |
| Max. lifting height | h3 | 6.9 m |
| Max. outreach | r1 | 3.9 m |
| Reach at max. height | | 1 m |
| Breakout force with bucket | | 5761 daN |
| Weight and dimensions | | |
| Unladen weight (with forks) | | 7710 kg |
| Ground clearance | m4 | 0.42 m |
| Wheelbase | y | 2.81 m |
| Overall length to carriage (with hitch) | l11 | 4.97 m |
| Front overhang | | 1.21 m |
| Overall width | b1 | 2.39 m |
| Overall cab width | b4 | 0.95 m |
| Overall height | h17 | 2.38 m |
| Tilt-down angle | a5 | 134 ° |
| Tilt-up angle | a4 | 12 ° |
| External turning radius (over tyres) | Wa1 | 3.93 m |
| Standard tyres | | Alliance - A580 - 460/70 R24 159A8 |
| Drive wheels (front / rear) | | 2 / 2 |
| Steering wheels (front / rear) | | 2 / 2 |
| Performances | | |
| Lifting | | 7.5 s |
| Lowering | | 7.6 s |
| Extension | | 6.6 s |
| Retraction | | 5.9 s |
| Crowd | | 3.4 s |
| Dump | | 3 s |
| Engine | | |
| Engine brand | | Deutz |
| Engine norm | | Stage III A |
| Engine model | | TCD 3.6 l |
| Number of cylinders - Capacity of cylinders | | 4 - 3621 cm ³ |
| I.C. Engine power rating / Power (kW) | | 136 Hp / 100 kW |
| Max. torque / Engine rotation | | 500 Nm @1600 rpm |
| Drawbar pull (Laden) | | 6450 daN |
| Reversible fan | | Standard |
| Engine cooling system | | 4 radiators (water + intercooler + hydraulic oil + transmission oil) |
| Transmission | | |
| Transmission type | | M-Vario Plus |
| Max. travel speed (may vary according to applicable regulations) | | 40 km/h |
| Differential lock | | Limited slip differential on front axle |
| Parking brake | | Automatic negative parking brake |
| Service brake | | Oil-immersed multi-discs braking on front & rear axles |
| Hydraulics | | |
| Hydraulic pump type | | Load sensing pump |
| Hydraulic flow - Pressure | | 170 l/min - 270 Bar |
| Flow sharing distributor | | Standard |
| Tank capacities | | |
| Hydraulic oil | | 135 l |
| Fuel tank | | 120 l |
| Noise and vibration | | |
| Noise at driving position (LpA) tested following NF EN 12053 norm | | 73 dB(A) |
| Environmental noise (LwA) | | 106 dB(A) |
| Vibration to whole hand/arm | | <2,50 m/s |
| Miscellaneous | | |
| Tractor homologation | | |
| Safety cab homologation | | ROPS/FOPS |
| Controls | | JSM |

Load chart

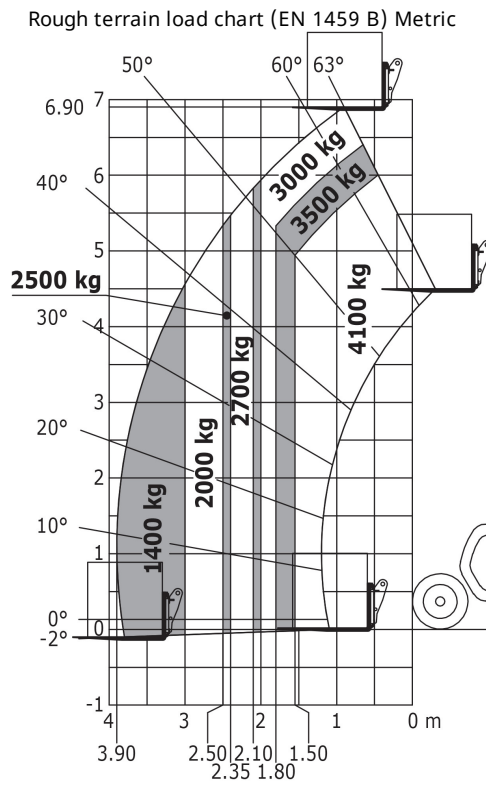

Dimensional drawing

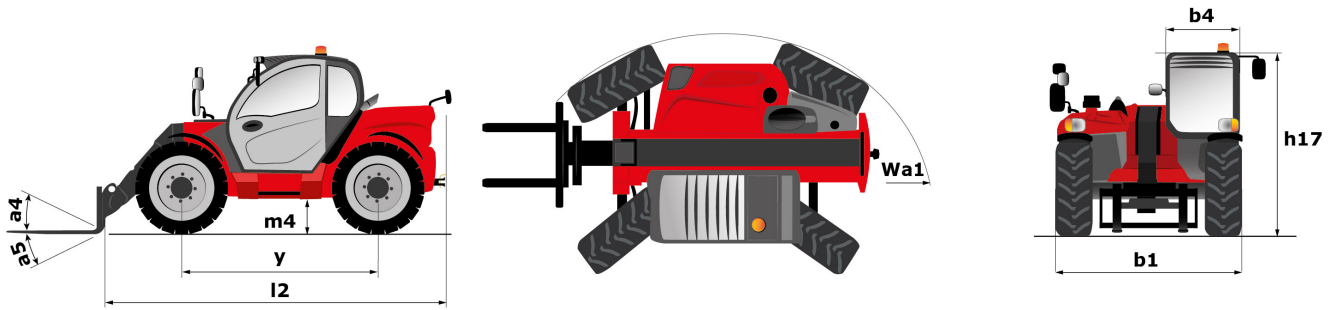

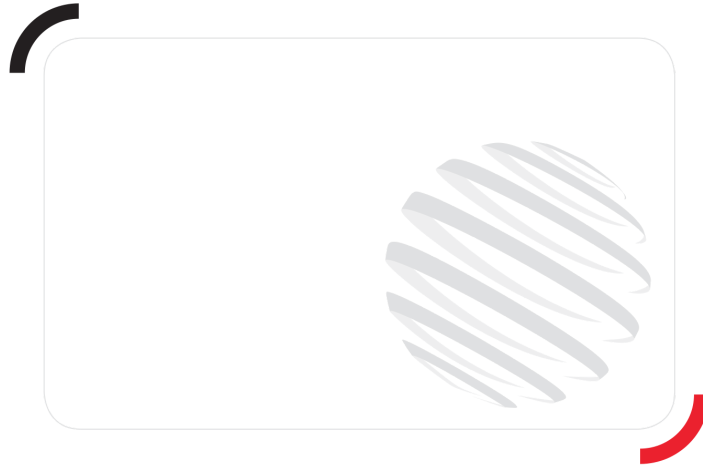

Siège Social
430 rue de l'Aubinière - 44150 Ancenis Cedex - France
Tel: +33(0)2 40 09 10 11 - Fax: +33 (0)2 40 09 10 97
www.manitou.com



This brochure describes versions and configuration options for Manitou products which may be fitted with different equipment. The equipment described in this brochure may be standard, optional or not available depending on version. Manitou reserves the right to change the specifications shown and described at any time and without prior warning. The manufacturer is not liable for the specifications given. For more information, contact your Manitou dealer. Non-contractual document. Product descriptions may differ from actual products. List of specifications is not comprehensive. The logos and visual identity of the company are the property of Manitou and may not be used without authorisation. All rights reserved. The photos and diagrams contained in this brochure are provided for information only.

MANITOU BF SA - Limited company with board of directors - Share capital: 39,668,399 euros - 857 802 508
RCS Nantes