

Hyworth 2.5T 4 Wheel Electric Counterbalance

Distinguishing Mark	1.1	Hyworth 2.5T 4 Wheel Electric Counterbalance			
	1.2	Model Number		H25BE4W	
	1.4	Operator Type		Seated	
	1.5	Rated Capacity / rated load	Q (kg)	2500	
	1.6	Load centre distance	c (mm)	600	
	1.8	Load centre distance	c (mm)	435	
	1.9	Wheelbase	y (mm)	1750	
Weight	2.1	Service Weight	kg	5100	
	2.2	Axle loading: laden front / rear	kg	6620/980	
	2.3	Axle loading: unladen front / rear	kg	2500/2600	
Tyres, chassis	3.1	Tyres		pneumatic	
	3.2	Tyre Size: front	mm	23x9-10	
	3.3	Tyre size: rear	mm	18x7-8	
	3.5	Wheel: number front / rear (x + driven wheels)		2 x /2	
	3.6	Tread: front	b10 (mm)	1073	
	3.7	Tread: rear	b11 (mm)	960	
	Dimensions	4.1	Tilt pf mast / fork carriage forward / backward	α/β (°)	5/8
4.2		Height: mast lowered	h1 (mm)	2160	
4.3		Free lift	h2 (mm)	150	
4.4		Lift	h3 (mm)	3000	
4.5		Height: mast extended	h4 (mm)	4100	
4.7		Height of overhead guard STD	h6 (mm)	2240	
4.9		Seat height / stand height	h7 (mm)	1190	
4.12		Coupling height	h10 (mm)	625	
4.19		Overall length	l1 (mm)	3560	
4.20		Length to face of forks	l2 (mm)	2490	
4.21		Overall width	b1 (mm)	1275	
4.22		Fork dimensions ISO 2331	s/e/l (mm)	40/122/1070	
4.23		Fork carriage DIN 15 173 – ISO 2328: class type A,B		ISO2328 2A	
4.24		Fork carriage width	b3 (mm)	1100	
4.25		Distance between fork arms	b2 (mm)	290/1100	
4.31		Ground clearance, laden, below mast	m1 (mm)	105	
4.32		Ground clearance, centre of wheelbase	m2 (mm)	110	
4.34.1		Aisle width for pallets 1000 x 1200 crossways	Ast (mm)	3835	
4.34.2		Aisle width for pallets 800 x 1200 lengthways	Ast (mm)	4035	
4.35		Turning radius	Wa (mm)	2400	
4.36	Internal turning radius	b13 (mm)	730		
Performance Data	5.1	Travel speed: laden / unladen	km/h	19/20	
	5.2	Lift speed: laden / unladen	m/s	0.480/0.620	
	5.3	Lowering speed: laden / unladen	m/s	0.470/0.420	
	5.5	Drawbar pull: laden / unladen	N	14000/15000	
	5.6	Max. Drawbar pull: laden / unladen	N	16/21	
	5.7	Gradeability: laden / unladen	%	18/25	
	5.8	Max. Gradeability: laden / unladen	%	4.3/3.8	
	5.10	Service brake		Hydraulic	
	5.11	Parking brake		Mechanical	
	Electric engine	6.1	Drive motor rating S2 60 min	kW	18.5 AC
		6.2	Lift motor rating at S3 15%	kW	25.4AC
6.3		Battery acc. To DIN 43 531/35/36 A,B,C no		DIN43536 A	
6.4		Battery voltage: rated capacity	V/Ah	48/630	
6.5		Battery weight	kg	1863	
		Battery dimensions	l/b/h (mm)	1028x855x784	

	6.6	Energy Consumptions acc. to VDI cycle	kWh/h	10.5
		Minimum battery weight	kg	1950
		Maximum battery weight	kg	1800
	8.1	Type of drive control		MOSFET/AC
	9.1	Manufacturer		CURTIS
Additional data	10.1	Operating pressure for attachments	bar	175
	10.2	Oil volume for attachments	l/min	40
	10.3	Hydraulic Tank = capacity (drain & fill)	litre	24
	10.7	Sound level at the drivers ear according to EN/DIN 12 053	dβ (A)	71
	10.8	Towing coupling, type DIN		ø24 Pin

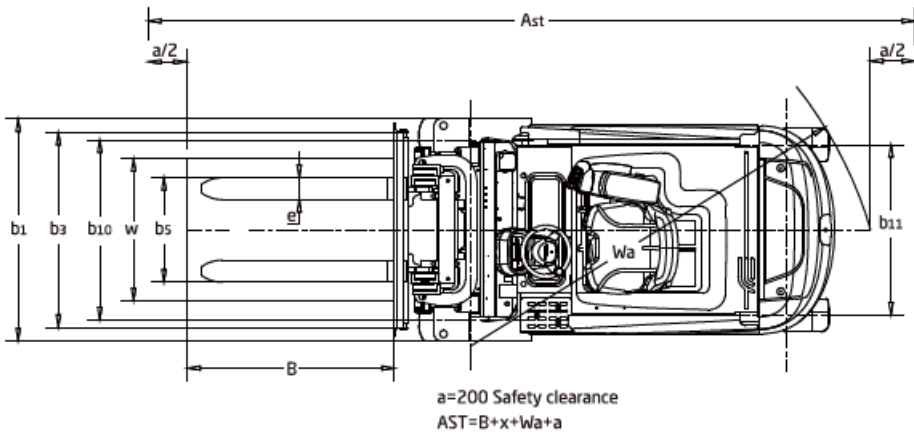
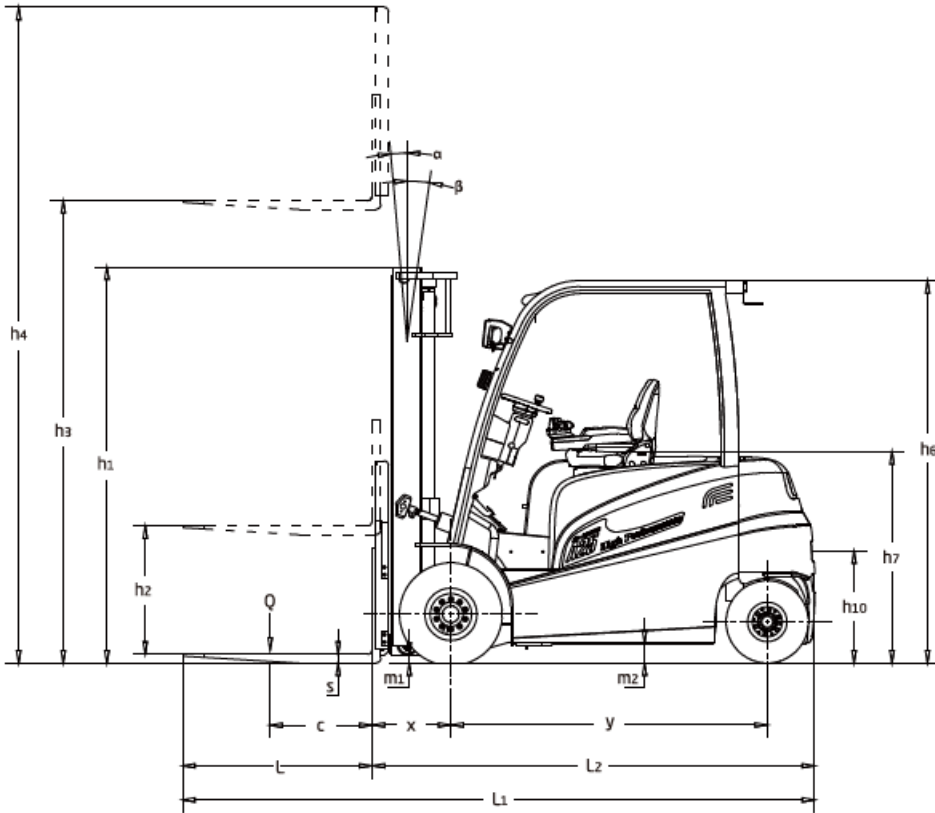

HYWORTH®
F O R K L I F T S

2/12 Weld Street PRESTONS NSW 2170
1300 HYWORTH (1300 499 678)
info@hyworthforklifts.com.au
www.hyworthforklifts.com.au