

## Model 75

INCLUDING: OPERATION, INSTRUCTION, INSTALLATION, MAINTENANCE AND PARTSBOOK



**IMPORTANT: READ THIS MANUAL CAREFULLY BEFORE INSTALLING, OPERATING OR  
SERVICING THIS TOOL.**

### BEEF SPLITTING SAW















#### TOOL DATA

MODEL: KENTMASTER 75  
ASSEMBLY No. 1070000  
TYPE: ELECTRICAL OPERATED  
NET WEIGHT: 136 LB (62 KG)  
MOTOR HORSEPOWER: 2HP / 50Hz, 60Hz



 <b>WARNING</b>	= Hazards or unsafe practices which could result in severe personal injury, death or substantial property damage.
 <b>CAUTION</b>	= Hazards or unsafe practices which could result in minor personal injury, product or property damage.
 <b>NOTICE</b>	= Important installation, operation or maintenance information.

## OPERATING AND SAFETY INSTRUCTIONS

-  **WARNING** DO NOT OPERATE THIS TOOL UNTIL YOU HAVE READ AND UNDERSTOOD THE SAFETY INSTRUCTIONS AND OPERATING MANUALS.
-  **WARNING** DO NOT OPERATE THIS TOOL UNTIL YOU HAVE RECEIVED TRAINING IN THE HANDLING, OPERATION AND USE OF THIS TOOL.
-  **WARNING** STOP USING A MALFUNCTIONING OR DEFECTIVE TOOL IMMEDIATELY. REPORT ANY PROBLEMS OR DEFECTS TO YOUR SUPERVISOR FOR REMOVAL OF THE TOOL FROM SERVICE.
-  **WARNING** DO NOT ATTEMPT TO REPAIR THE TOOL YOURSELF.
-  **WARNING** DO NOT ALLOW UNAUTHORIZED PERSONS TO USE TOOL.
-  **WARNING** REMOVE AND DISCONNECT POWER FROM THE TOOL WHEN TOOL IS LEFT UNATTENDED OR IS NOT IN USE.
-  **WARNING** NEVER TIE DOWN, BYPASS, ALTER OR MODIFY THE ACTIVATING SWITCHES OR TRIGGERS OF THIS TOOL.
-  **WARNING** NEVER MAKE ALTERATIONS OR MODIFICATIONS TO THIS TOOL.
-  **WARNING** BE CONSTANTLY AWARE AND ALERT FOR UNSAFE CONDITIONS AND REPORT THEM IMMEDIATELY TO YOUR SUPERVISOR.
-  **WARNING** NEVER PLACE YOUR HAND OR ANY PART OF YOUR BODY IN THE CUTTING PATH OF THE TOOL.
-  **WARNING** NEVER ALLOW ANYONE ELSE TO PLACE THEIR HANDS OR ANY PART OF THEIR BODY IN THE CUTTING PATH OF THE TOOL.
-  **WARNING** DO NOT ACTIVATE CONTROL SWITCHES OR TRIGGERS OF THIS TOOL UNLESS YOU INTEND TO TEST OR OPERATE THIS TOOL.
-  **WARNING** DO NOT USE THIS TOOL FOR ANY PURPOSE OTHER THAN IT'S INTENDED PURPOSE.
- WHEN OPERATING THIS TOOL WEAR THE PROTECTIVE GEAR AND SAFETY EQUIPMENT SUPPLIED TO YOU.
-  **CAUTION**
-  **WARNING** THE NOISE EMISSION (SOUND PRESSURE LEVEL) AT THE WORKSTATION MAY EXCEED 80 dB (A). EAR AND SOUND PROTECTION GEAR IS REQUIRED.

## SERVICE

1. KEEP GOOD RECORDS OF ALL SERVICE ACTIVITY AND INCLUDE TOOL IN PREVENTIVE MAINTENANCE PROGRAM.
2. USE ONLY GENUINE KENTMASTER REPLACEMENT PARTS TO ASSURE PROPER PERFORMANCE OF TOOL.
3. CONTACT THE KENTMASTER SUPPLIER NEAREST YOU FOR PARTS AND CUSTOMER SERVICE INFORMATION.

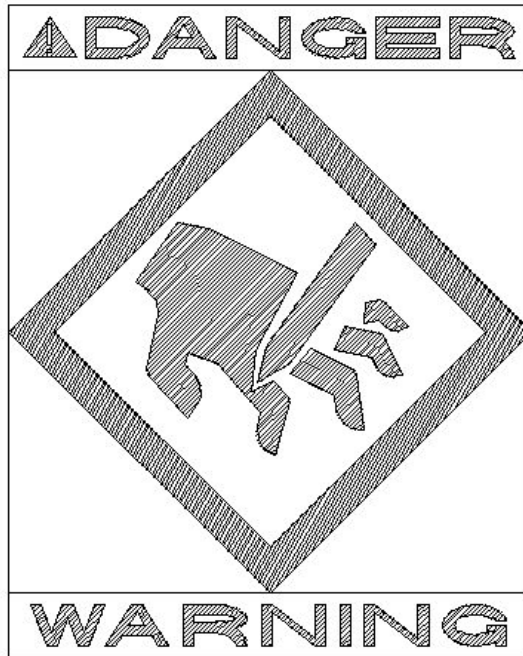

# PARTS BOOK

## "75" MAIN ASSEMBLY

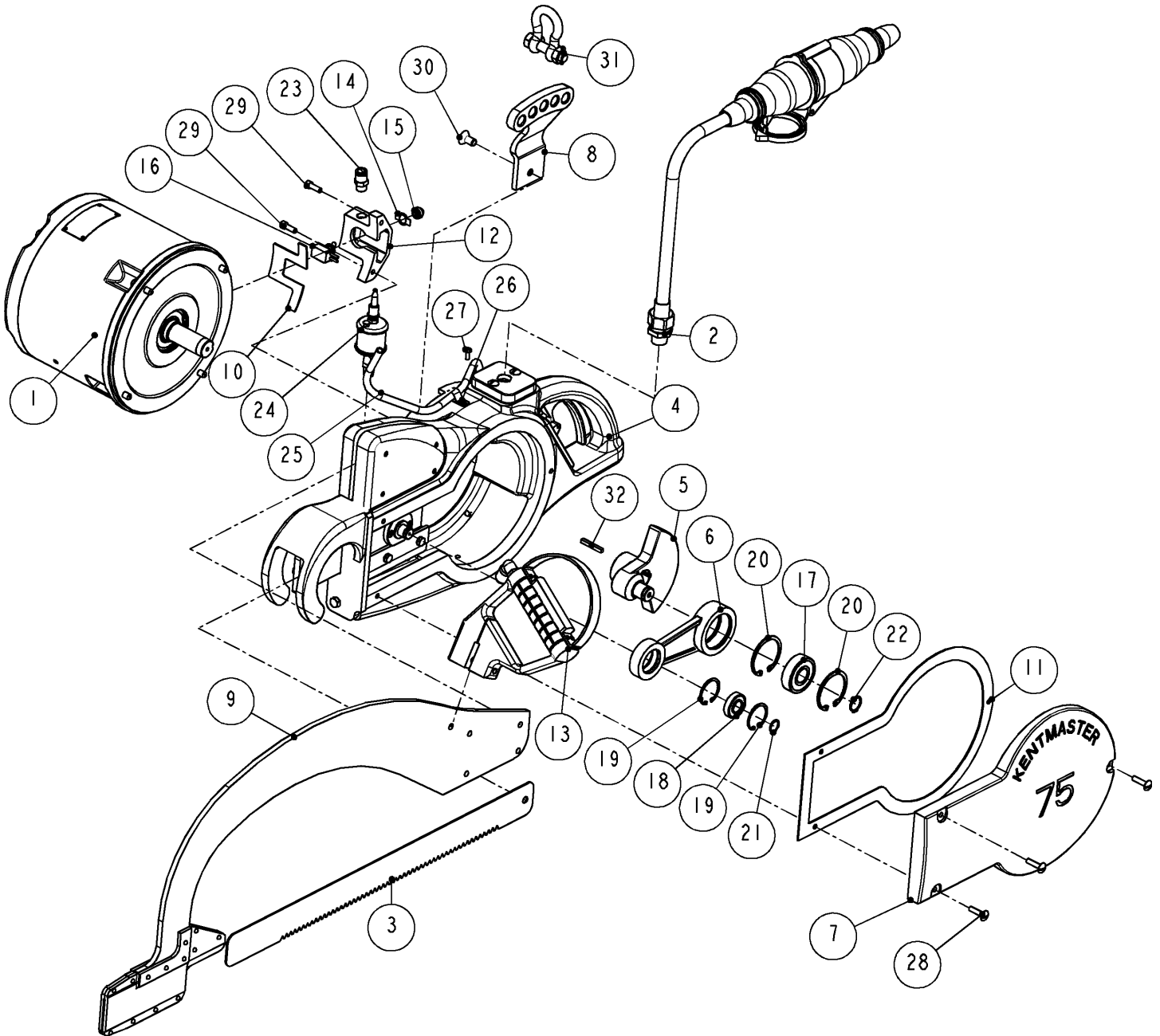

**Figure 1 MODEL "75"**

<b>1070000: 75 - BEEF SPLITTING SAW</b>			
ITEM	PART #	DESCRIPTION	QTY
1	<b>OPTIONS</b>	MOTOR ASSEMBLY/ <b>SEE OPTION CHART</b>	1
2	1002422	POWER SUPPLY, NON 42V, 3 PHASE	1
	1002423	POWER SUPPLY, 115/230V, SINGLE PHASE	1
	1002430	POWER SUPPLY, 42V, 3 PHASE	1
3	4100100	BLADE, 3 TPI (STANDARD)	1
	4100110	BLADE,"SKIP TOOTH", 2 TPI	1
4	1070011	FRAME ASSEMBLY	1
5	1070030	ECCENTRIC	1
6	1070040	CONNECTING ROD	1
7	1070111	COVER	1
8	1070201	HANGER	1
9	1070750	YOKE	1
10	1070930	GASKET	1
11	1071310	GASKET	1
12	1071480	WIRE BOX	1
13	1710310	TOP HANDLE WITH SWITCH	1
14	2000130	ON-OFF PLATE	1
15	2000140	BOOT, TOGGLE SWITCH	1
16	2000150	SWITCH	1
17	3304040	BEARING	1
18	3601200	BEARING	1
19	5001370	RETAINING RING	2
20	5002060	RETAINING RING	2
21	5100620	RETAINING RING	1
22	5100780	RETAINING RING	1
23	7036140	FITTING	1
24	7236020	LUBE DEVICE	1
25	7300750	TUBE	1
26	7801000	CUSHIONED LOOP STRAP	1
27	8090040	SCREW	1
28	8111080	SCREW	3
29	8211060	SCREW	2
30	8245060	SCREW	1
31	8462080	ANCHOR SHACKLE	1
32	8603110	SQUARE KEY	1

**Figure 2 BOM FOR MODEL "75"**

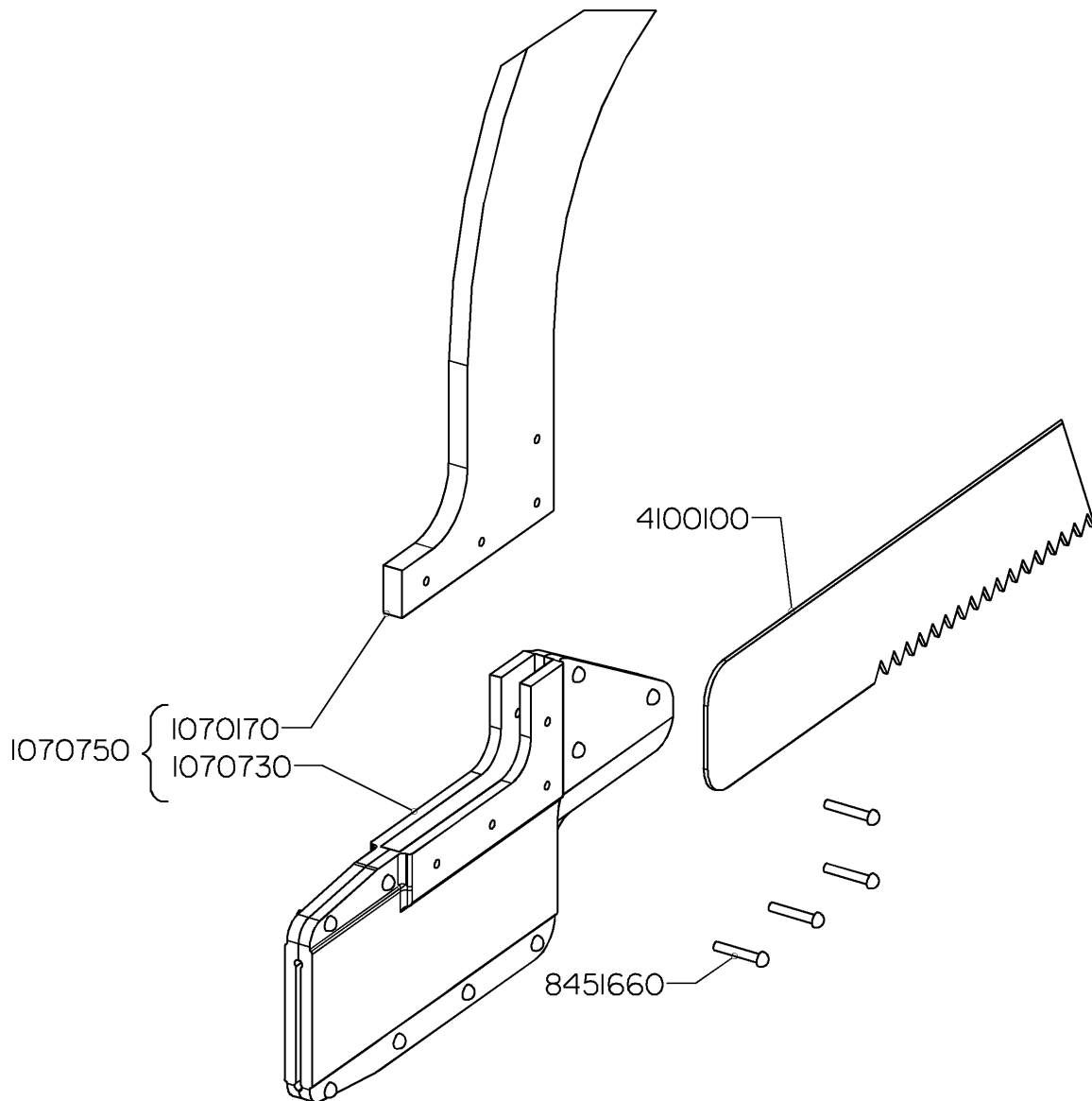
**Instructions for replacement of yoke end**

1. Drill out four rivets (8451660) and remove worn out yoke end (1070730).
2. Install new yoke end (1070730) on yoke and align yoke end **before** drilling new rivet holes.
3. Install saw blade to assist in alignment of yoke end.
4. Drill new holes and rivet yoke end (1070730) to yoke (1070170).

**Figure 3 Yoke end replacement**

**MOTOR ASSEMBLY**

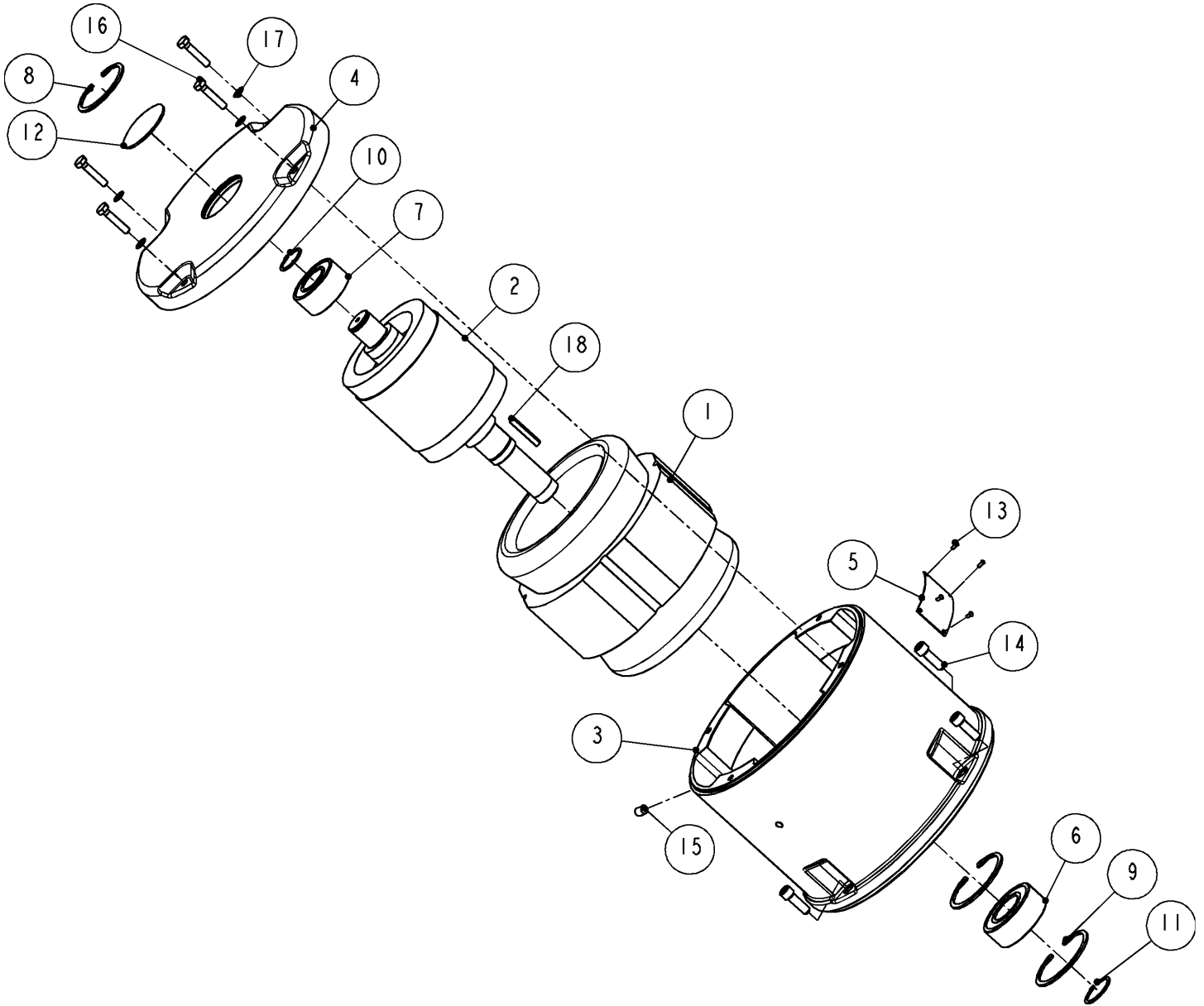

**Figure 4 MOTOR ASSEMBLY**

<b>MOTOR ASSEMBLY</b>			
ITEM	PART #	DESCRIPTION	QTY
1	<b>OPTIONS</b>	STATOR / <b>SEE CHART 1 BELOW</b>	1
2	1071630	ROTOR - SHAFT ASSEMBLY – 3 PHASE	1
	1071640	ROTOR - SHAFT ASSEMBLY – 1 PH/60Hz	1
	1071641	ROTOR - SHAFT ASSEMBLY – 1 PH/50Hz	1
3	1071650	MOTOR HOUSING	1
4	1501800	COVER, MOTOR HOUSING	1
5	2000040	NAME PLATE	1
6	3522060	BEARING	1
7	3524050	BEARING	1
8	5002120	RETAINING RING	1
9	5002440	RETAINING RING	2
10	5100980	RETAINING RING	1
11	5101180	RETAINING RING	1
12	7902170	EXPANSION PLUG	1
13	8023020	SCREW	4
14	8213080	SCREW	4
15	8313040	SET SCREW	1
16	8411100	SCREW	4
17	8507100	WASHER	4
18	8603110	KEY	1

MOTOR ASS'Y 230V, 2HP, 1PH, 50HZ, 12.2AMPS	1071770-230-150	1071641	2340270
MOTOR ASS'Y 115V, 2HP, 1PH, 50HZ, 24.4AMPS	1071770-115-150	1071641	2340270
MOTOR ASS'Y 230V, 2HP, 1PH, 60HZ, 11.4AMPS	1071760-230-160	1071640	2340260
MOTOR ASS'Y 115V, 2HP, 1PH, 60HZ, 23.4AMPS	1071760-115-160	1071640	2340260
MOTOR ASS'Y 380V, 2HP, 3PH, 50HZ, 3.7AMPS	1071720-380-350	1071630	2340220
MOTOR ASS'Y 220V, 2HP, 3PH, 50HZ, 6.4AMPS	1071720-220-350	1071630	2340220
MOTOR ASS'Y 230V, 2HP, 3PH, 50HZ, 6.6AMPS	1071710-230-350	1071630	2340210
MOTOR ASS'Y 115V, 2HP, 3PH, 50HZ, 13.2AMPS	1071710-115-350	1071630	2340210
MOTOR ASS'Y 42V, 2HP, 3PH, 50HZ, 36.0AMPS	1071700	1071630	2340200
MOTOR ASS'Y 550V, 2HP, 3PH, 60HZ, 2.8AMPS	1071750	1071630	2340250
MOTOR ASS'Y 380V, 2HP, 3PH, 60HZ, 3.9AMPS	1071740	1071630	2340240
MOTOR ASS'Y 460V, 2HP, 3PH, 60HZ, 3.3AMPS	1071730-460-360	1071630	2340230
MOTOR ASS'Y 230V, 2HP, 3PH, 60HZ, 6.6AMPS	1071730-230-360	1071630	2340230
MOTOR ASS'Y 416V, 2HP, 3PH, 60HZ, 3.3AMPS	1071730-416-360	1071630	2340230
MOTOR ASS'Y 208V, 2HP, 3PH, 60HZ, 6.6AMPS	1071730-208-360	1071630	2340230
<b>MOTOR OPTION DESCRIPTION</b>	<b>MOTOR ASSEMBLY</b>	<b>ROTOR (ITEM 2)</b>	<b>STATOR (ITEM 1)</b>
<b>CHART 1: "75" MOTOR OPTIONS</b>			

**Figure 5 BOM FOR MOTOR ASSEMBLY**



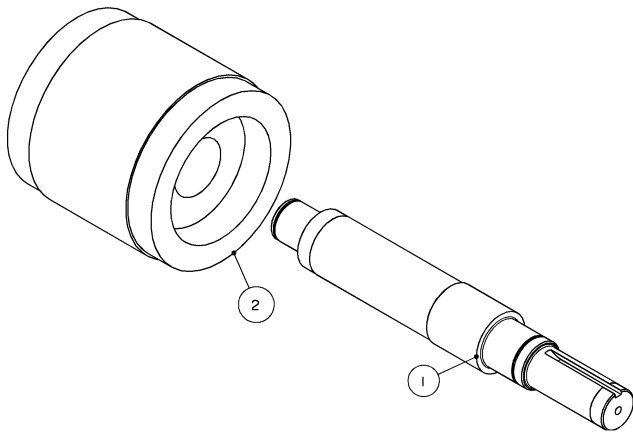

1071630: ROTOR - SHAFT ASSEMBLY- 3 PHASE 1071640: ROTOR - SHAFT ASSEMBLY- 1 PH/60Hz 1071641: ROTOR - SHAFT ASSEMBLY- 1 PH/50Hz			
ITEM	PART #	DESCRIPTION	QTY
1	1071620	SHAFT	1
2	2340620	ROTOR – 3 PHASE	1
2	2340630	ROTOR – 1 PHASE/60Hz	1
2	2340670	ROTOR – 1 PHASE/50Hz	1

**Figure 6 1071630 & 1071640 : ROTOR –SHAFT ASSEMBLY**

**POWER SUPPLY**

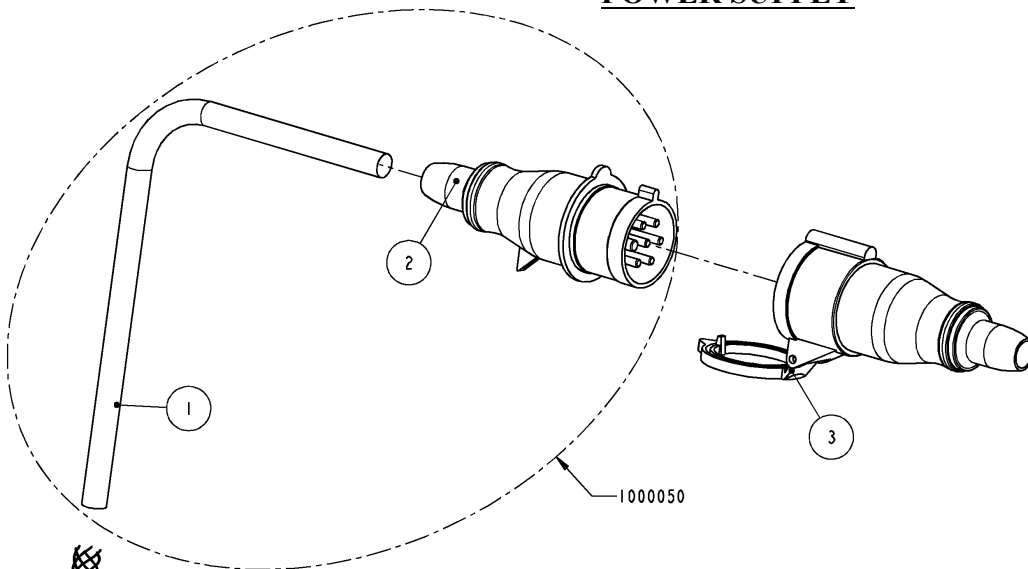

1002422: POWER CORD ASSEMBLY, NON 42V, 3 PHASE			
ITEM	PART #	DESCRIPTION	QTY
1	2001240	POWER CORD	1
2	2001610	PLUG, MALE	1
3	2001620	SOCKET, FEMALE	1
4	2008170	FITTING	1
5	2008220	CORD GRIP	1

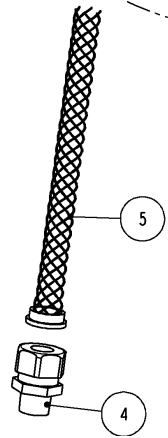

**Figure 7 1002422: POWER SUPPLY, NON 42V, 3 PHASE**

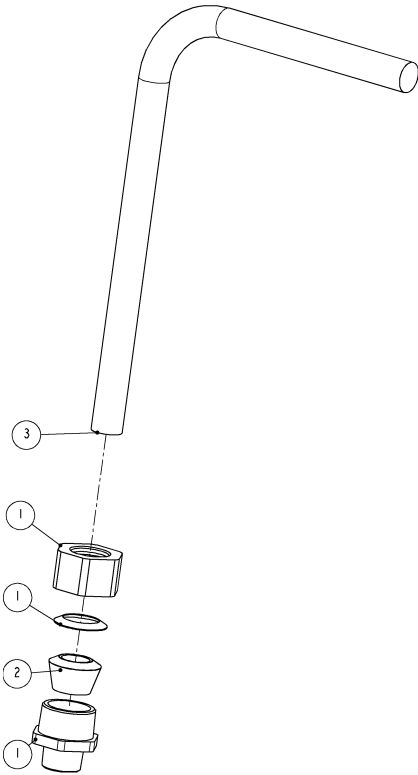

**1002430: POWER CORD ASSEMBLY, 42V**

ITEM	PART #	DESCRIPTION	QTY
1	2001270	CABLE CONNECTOR	1
2	2001700	GROMMET	1
3	2007030	POWER CORD	1

**Figure 8 1002430: POWER SUPPLY, 42V, 3 PHASE**

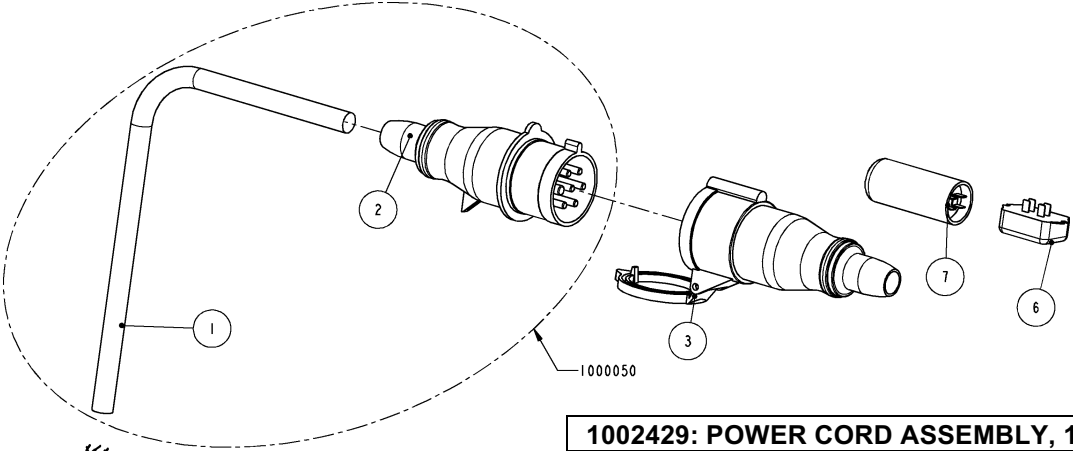

**1002429: POWER CORD ASSEMBLY, 115/230V, SINGLE PHASE**

ITEM	PART #	DESCRIPTION	QTY
1	2001080	POWER CORD	1
2	2001610	PLUG, MALE	1
3	2001620	SOCKET, FEMALE	1
4	2008170	FITTING	1
5	2008220	CORD GRIP	1
6	2309090	CAPACITOR START MOTOR	1
7	2309650	CAPACITOR	1

**Figure 9 1072429: POWER SUPPLY, 115/230V, SINGLE PHASE**

**FRONT HANDLE**

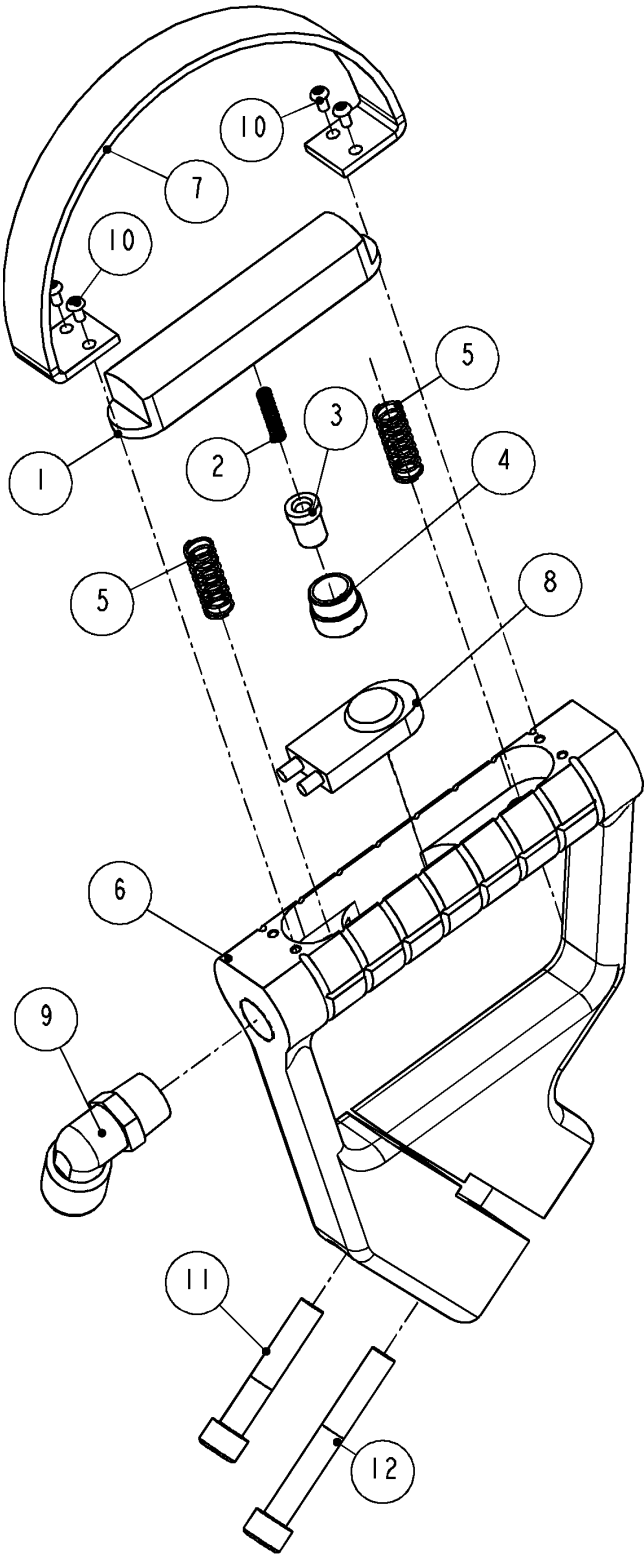

1710310: TOP HANDLE			
ITEM	PART #	DESCRIPTION	QTY
1	1302430	TRIGGER	1
2	1302440	SPRING	1
3	1302450	PLUNGER	1
4	1302460	HOLDER, PLUNGER	1
5	1701550	SPRING	2
6	1710290	HANDLE	1
7	1710570	GUARD	1
8	2000690	SWITCH	1
9	7036450	ELBOW	1
10	9045020	SCREW	4
11	9213140	SCREW	1
12	9213190	SCREW	1

**Figure 10 1710310: ELECTRIC HANDLE**

**FRAME ASSEMBLY**

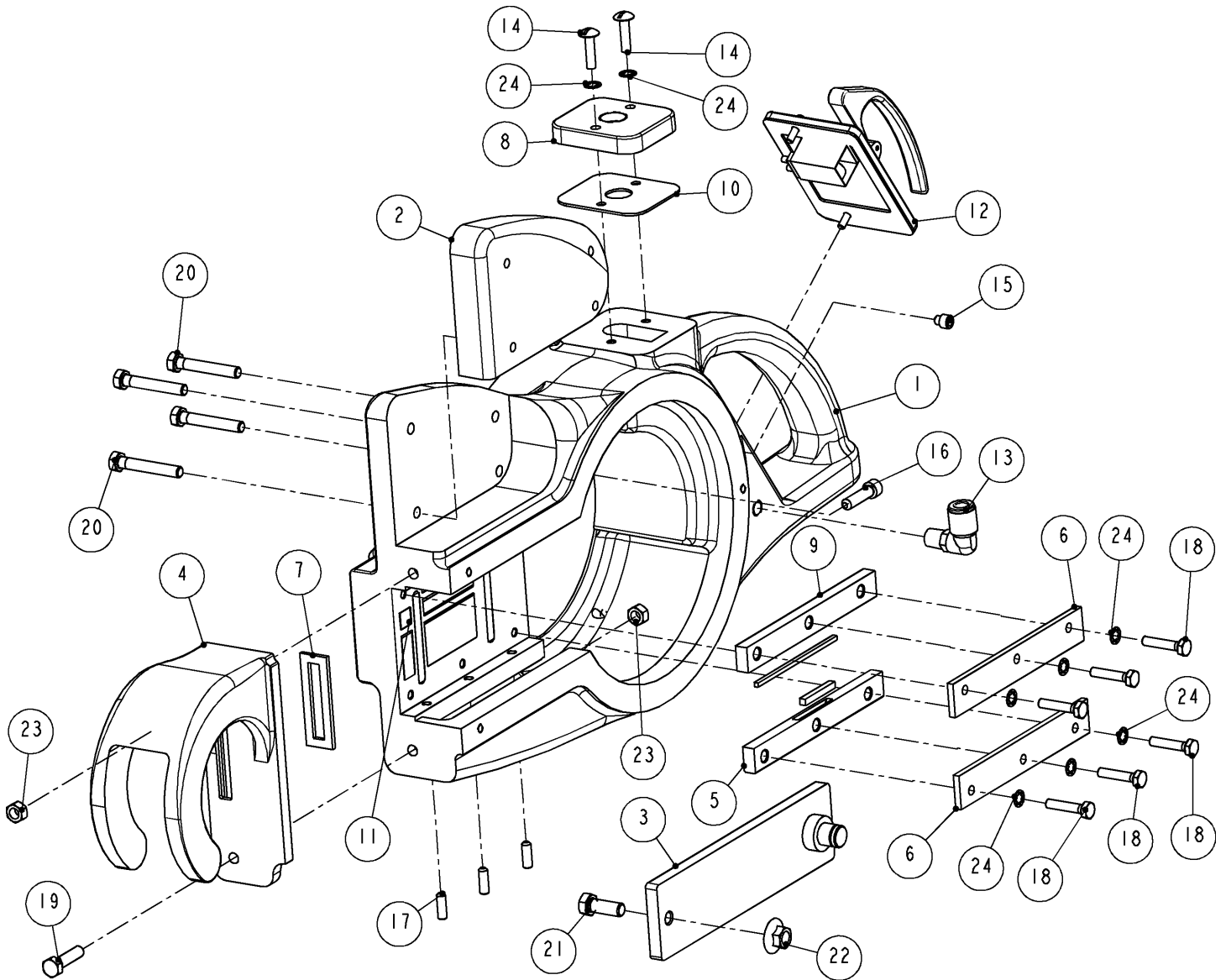

**Figure 11 1070011: FRAME ASSEMBLY**

1070011: FRAME ASSEMBLY			
ITEM	PART #	DESCRIPTION	QTY
1	1070010	HOUSING	1
2	1070020	HOUSING BLOCK	1
3	1070050	SLIDE	1
4	1070060	BONE GUIDE	1
5	1070250	GIB - LOWER	1
6	1070260	GIB PLATE	2
7	1070590	FELT WIPER, SLIDE	1
8	1070710	WIRE PLATE	1
9	1070720	GIB - UPPER	1
10	1071300	GASKET	1
11	1071320	LUBRICATING FELT, COMPLETE SET	1
12	1071470	ASSEMBLY, SWITCH PLATE	1
13	7036560	ELBOW	1
14	8111080	SCREW	2
15	8211020	SCREW	1
16	8213100	SCREW	1
17	8341060	SET SCREW	3
18	8411100	SCREW	6
19	8413100	SCREW	1
20	8413160	SCREW	4
21	8415080	SCREW	1
22	8500750	NUT	1
23	8501430	NUT	2
24	8507100	WASHER	8

**Figure 12 BOM FOR FRAME ASSEMBLY**

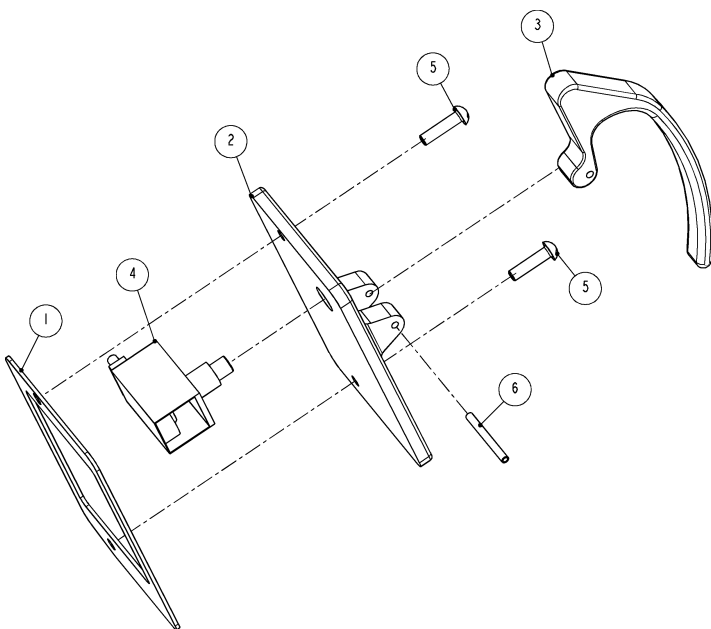

1071470: ASSEMBLY, SWITCH PLATE			
ITEM	PART #	DESCRIPTION	QTY
1	1071010	GASKET	1
2	1071440	SWITCH, PLATE	1
3	1071450	TRIGGER	1
4	2000700	SWITCH	1
5	8030060	SCREW	2
6	8612200	PIN	1

**Figure 13 1202470: HANGER ASSEMBLY**

**LUBRICATING FELT INSTALLATION**

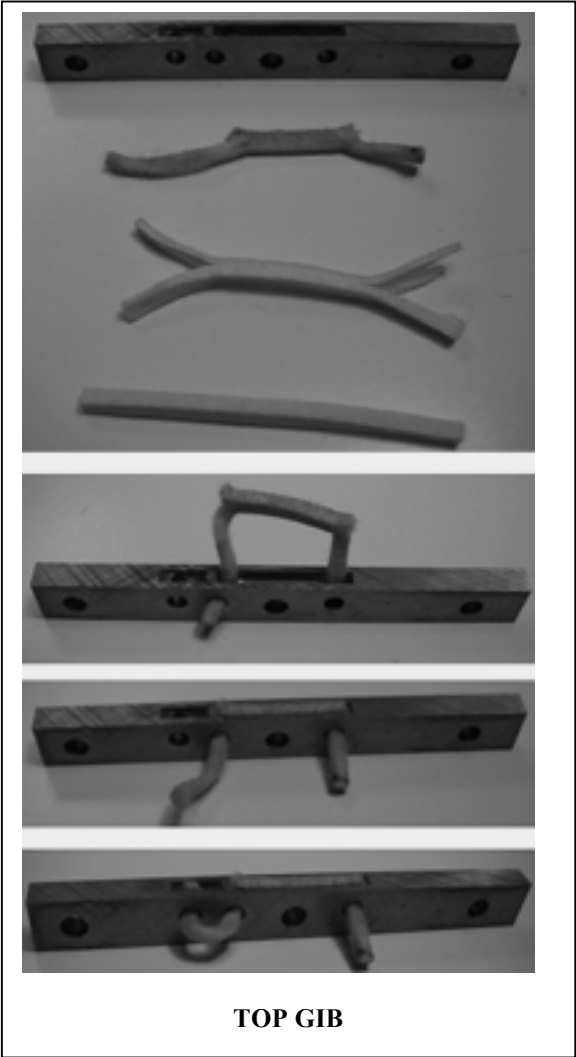
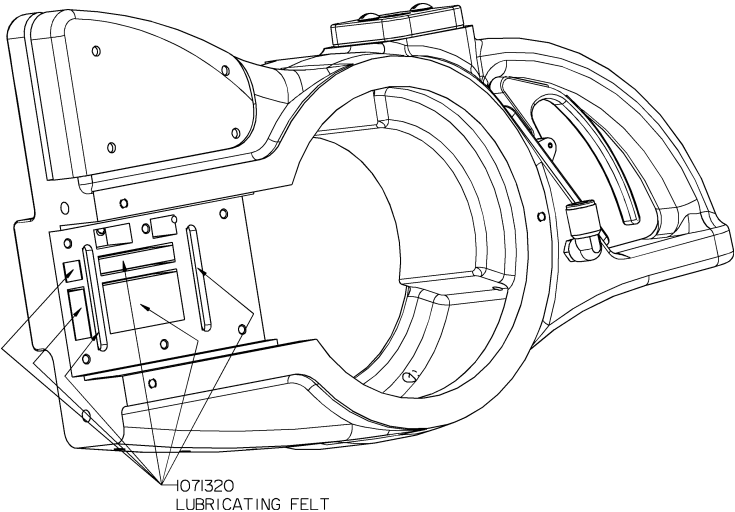

**Figure 14 1071320: LUBRICATING FELT SET**

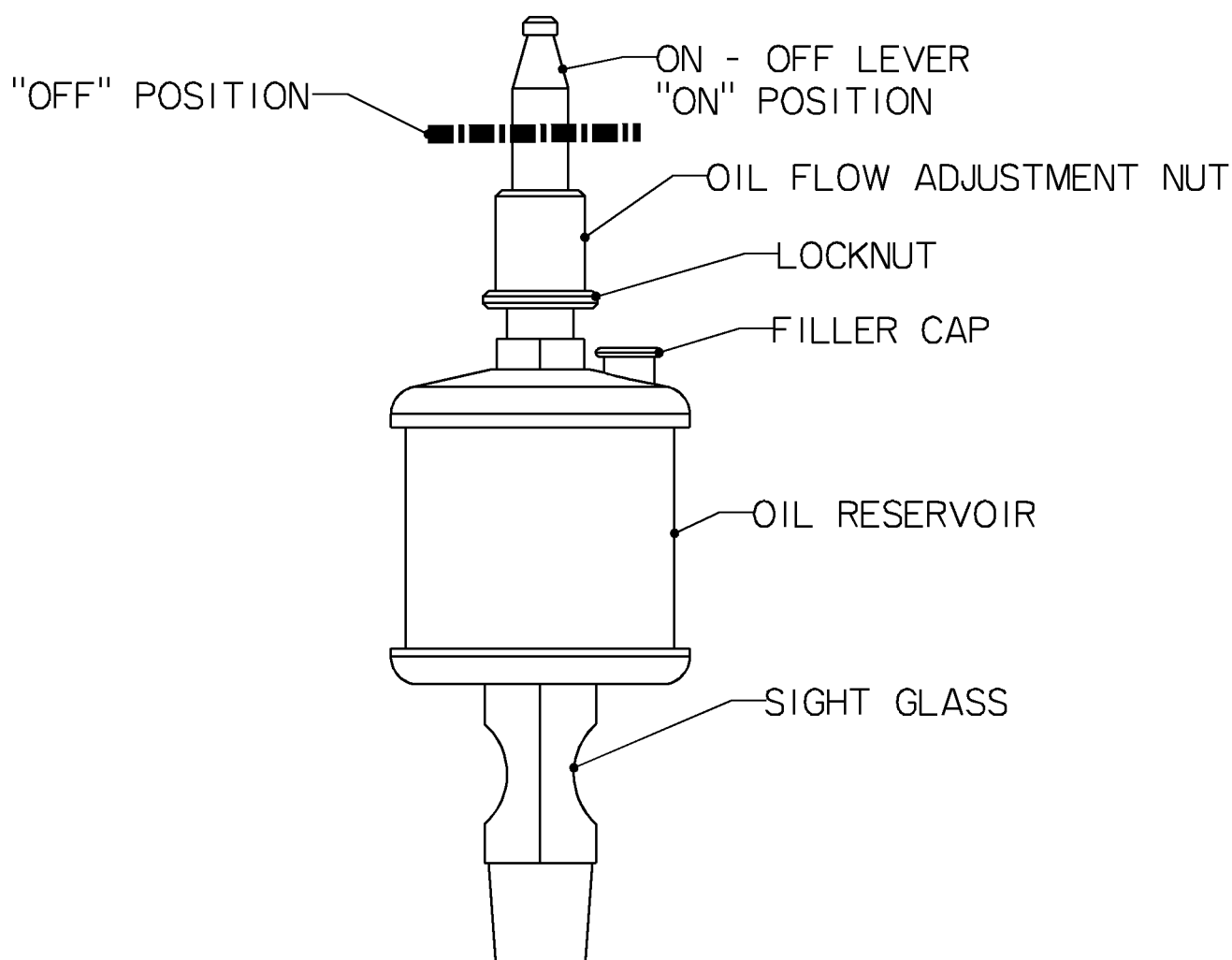
**DRIP FEED OIL CUP ADJUSTMENT**

Oil cup lubricates the slide and should be adjusted as follows:

1. Fill oil reservoir with light weight food grade oil.
2. Raise top On-Off lever upright to "ON" position.
3. Turn flow adjustment nut clockwise to obtain 3-5 drops per minute. Look thru sight glass.
4. Turn locknut against flow adjustment nut.
5. Turn oiler "ON" (lever upright) at beginning of work shift and drop lever at end of work shift for "OFF" position.
6. KEEP OIL RESERVOIR FULL.

**Figure 15 Oil cup adjustment**

**WIRING DIAGRAMS**

**3-PHASE, DIFFERENT CONTROL AND MOTOR VOLTAGE**

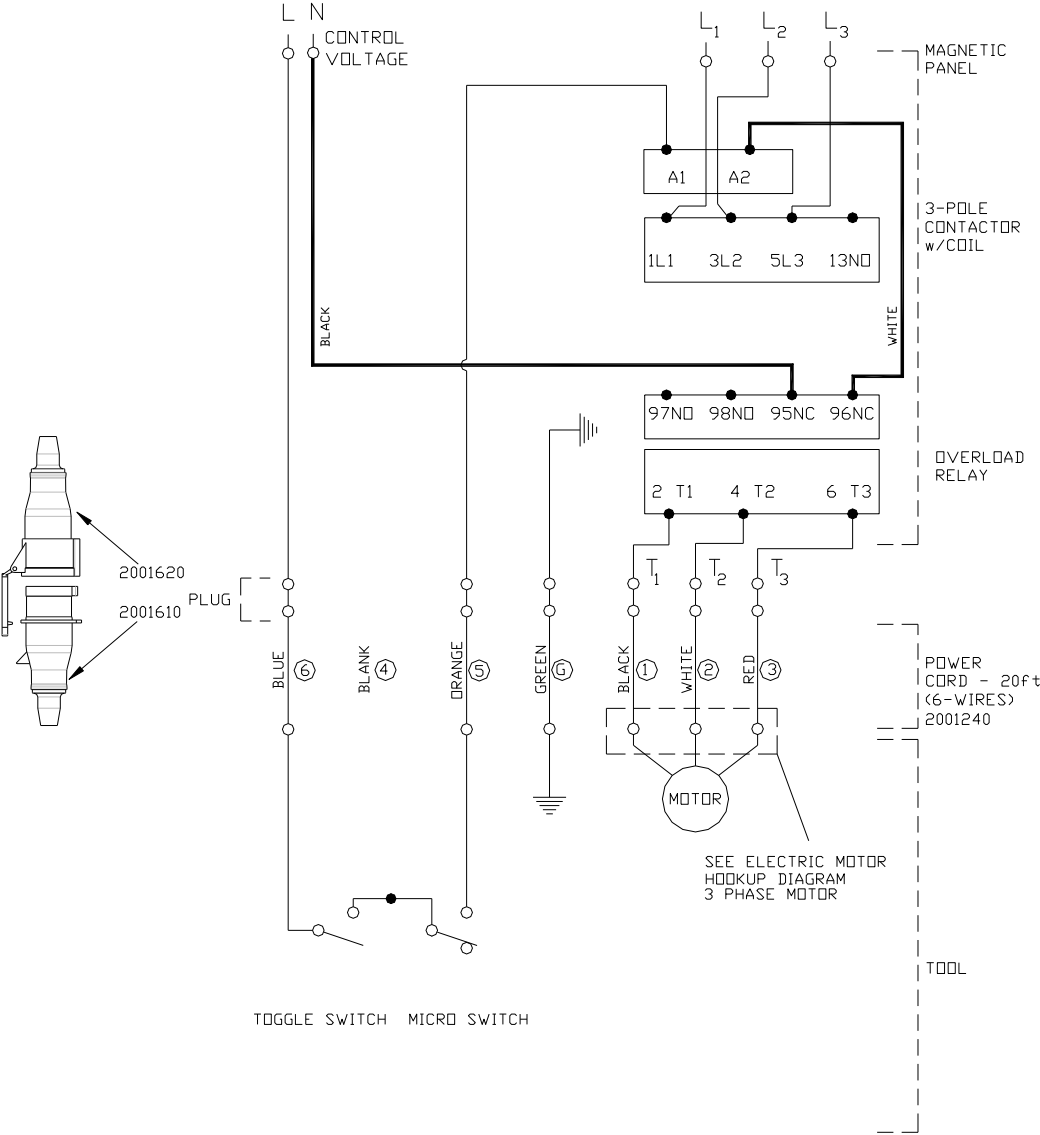

NOTES:

- 1. DO NOT ATTEMPT OR MAKE RAPAIRS ON THE MACHINE WHILE POWER IS ON.
- 2. ALL ELECTRICAL WORK MUST BE PERFORMED BY A QUALIFIED ELECTRICIAN.
- 3. THE ELECTRICAL DIAGRAM SHOWS THE MACHINE IN THE "OFF" POSITION.
- 4. THE GROUND WIRE (GREEN) OF THE POWER CABLE IS CONNECTED TO THE FRAME OF THE MACHINE.

**To obtain the correct Kentmaster part number for 3-pole contactor and overload relay, please contact the Kentmaster representative.**

**Figure 16 WIRING DIAGRAM – different control and motor voltage**



**3-PHASE, SAME CONTROL AND MOTOR VOLTAGE**

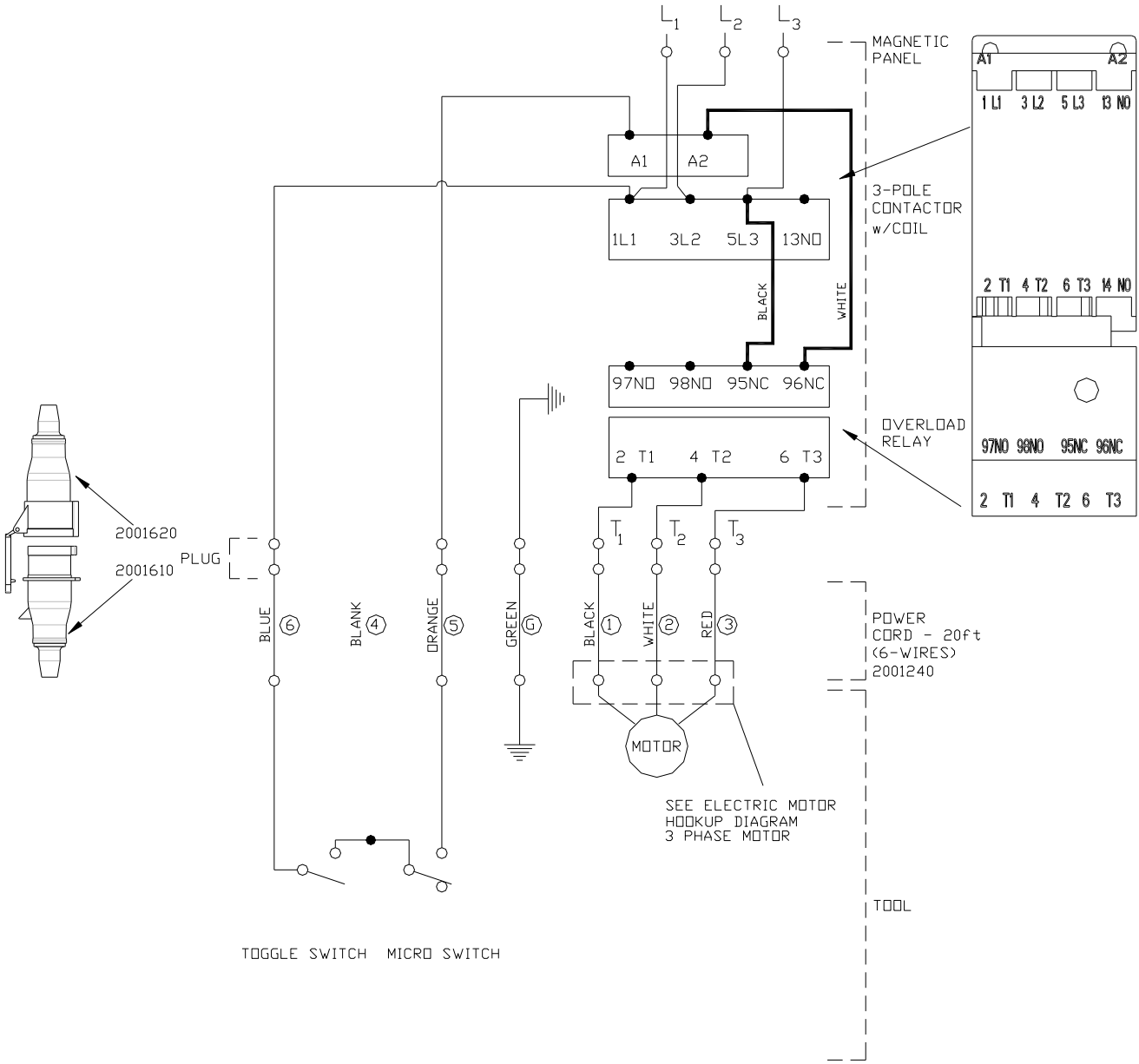

**NOTES:**

- 1. DO NOT ATTEMPT OR MAKE RAPAIRS ON THE MACHINE WHILE POWER IS ON.
- 2. ALL ELECTRICAL WORK MUST BE PERFORMED BY A QUALIFIED ELECTRICIAN.
- 3. THE ELECTRICAL DIAGRAM SHOWS THE MACHINE IN THE "OFF" POSITION.
- 4. THE GROUND WIRE (GREEN) OF THE POWER CABLE IS CONNECTED TO THE FRAME OF THE MACHINE.

**To obtain the correct Kentmaster part number for 3-pole contactor and overload relay, please contact the Kentmaster representative.**

**Figure 17 WIRING DIAGRAM – same control and motor voltage**

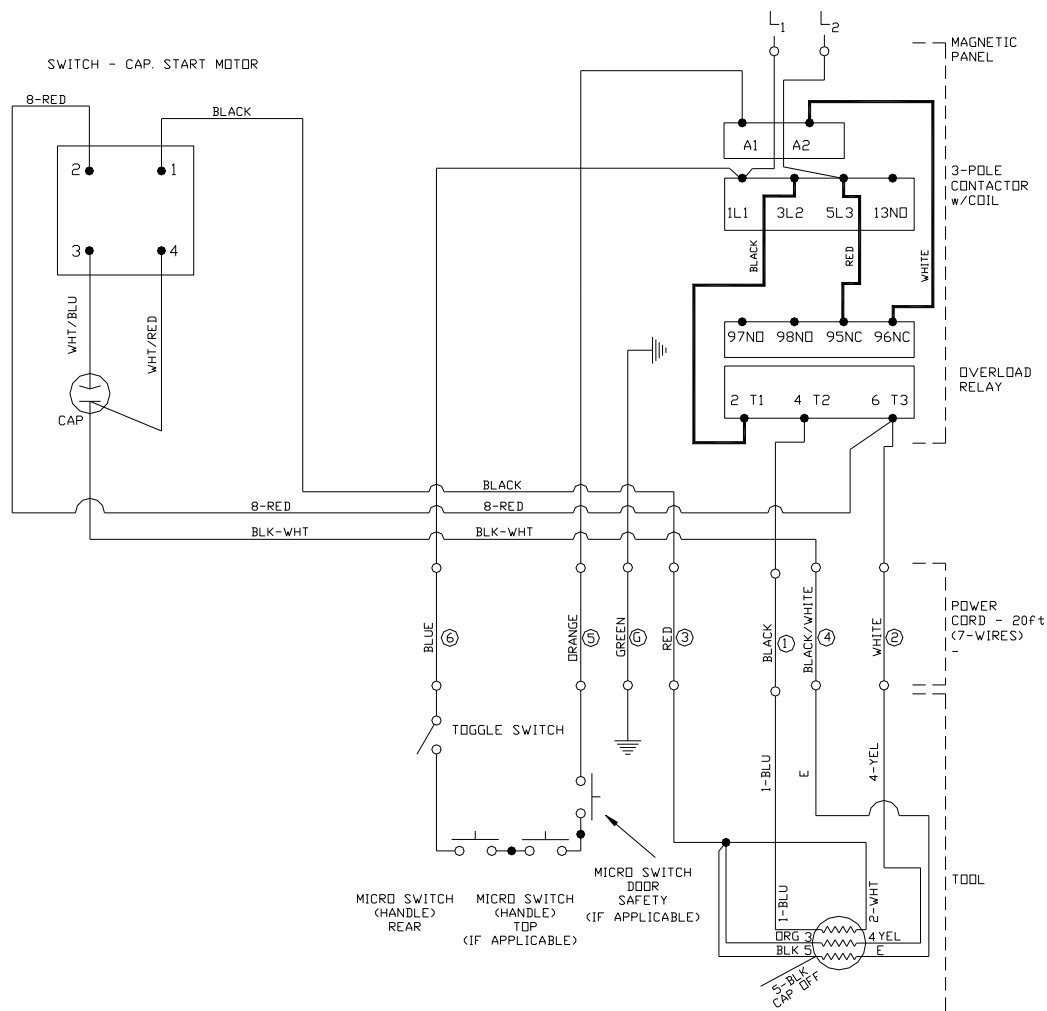
**SINGLE PHASE, 230 VOLTS**

## NOTES:

1. DO NOT ATTEMPT OR MAKE REPAIRS ON THE MACHINE WHILE POWER IS ON.
2. ALL ELECTRICAL WORK MUST BE PERFORMED BY A QUALIFIED ELECTRICIAN.
3. THE CAPACITOR AND THE SWITCH - CAP. START MOTOR ARE MOUNTED INSIDE THE MAGNETIC PANEL BOX.
4. THE ELECTRICAL DIAGRAM SHOWS THE MACHINE IN THE "OFF" POSITION.
5. MOTOR #7 LEAD IS UNUSED AND SHOULD BE INSULATED AND TAPED SEPARATELY.
6. THE GROUND WIRE (GREEN) OF THE POWER CABLE IS CONNECTED TO THE FRAME OF THE MACHINE.
7. TO REVERSE DIRECTION, REVERSE MOTOR WIRES #5 AND #8.

**To obtain the correct Kentmaster part number for 3-pole contactor and overload relay, please contact the Kentmaster representative.**

**Figure 18 WIRING DIAGRAM – SINGLE PHASE, 230V**

## SINGLE PHASE, 115 VOLTS

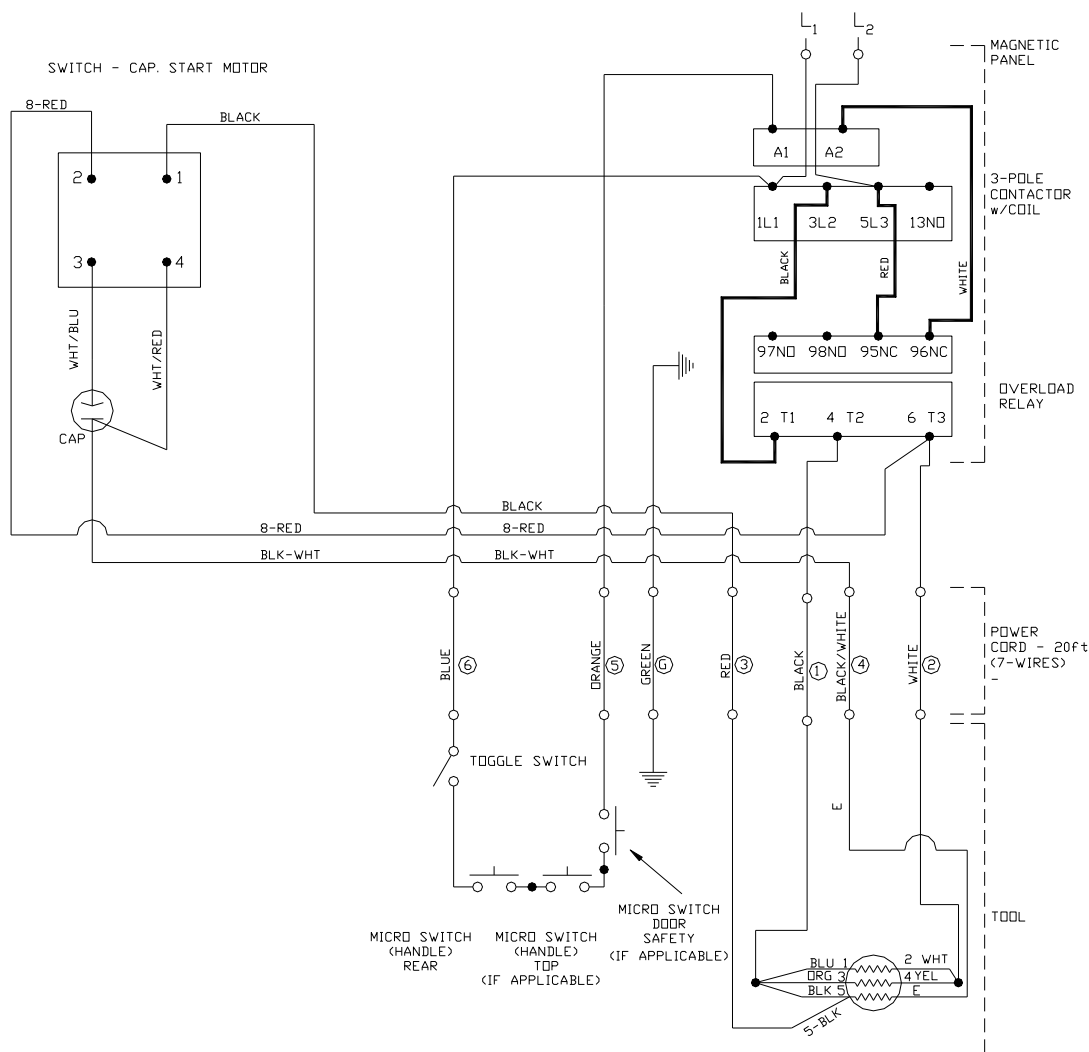

**NOTES:**

1. DO NOT ATTEMPT OR MAKE REPAIRS ON THE MACHINE WHILE POWER IS ON.
2. ALL ELECTRICAL WORK MUST BE PERFORMED BY A QUALIFIED ELECTRICIAN.
3. THE CAPACITOR AND THE SWITCH – CAP. START MOTOR ARE MOUNTED INSIDE THE MAGNETIC PANEL BOX.
4. THE ELECTRICAL DIAGRAM SHOWS THE MACHINE IN THE “OFF” POSITION.
5. MOTOR #7 LEAD IS UNUSED AND SHOULD BE INSULATED AND TAPED SEPARATELY.
6. THE GROUND WIRE (GREEN) OF THE POWER CABLE IS CONNECTED TO THE FRAME OF THE MACHINE.
7. TO REVERSE DIRECTION, REVERSE MOTOR WIRES #5 AND #8.

**To obtain the correct Kentmaster part number for 3-pole contactor and overload relay, please contact the Kentmaster representative.**

**Figure 19 WIRING DIAGRAM – SINGLE PHASE, 115V**

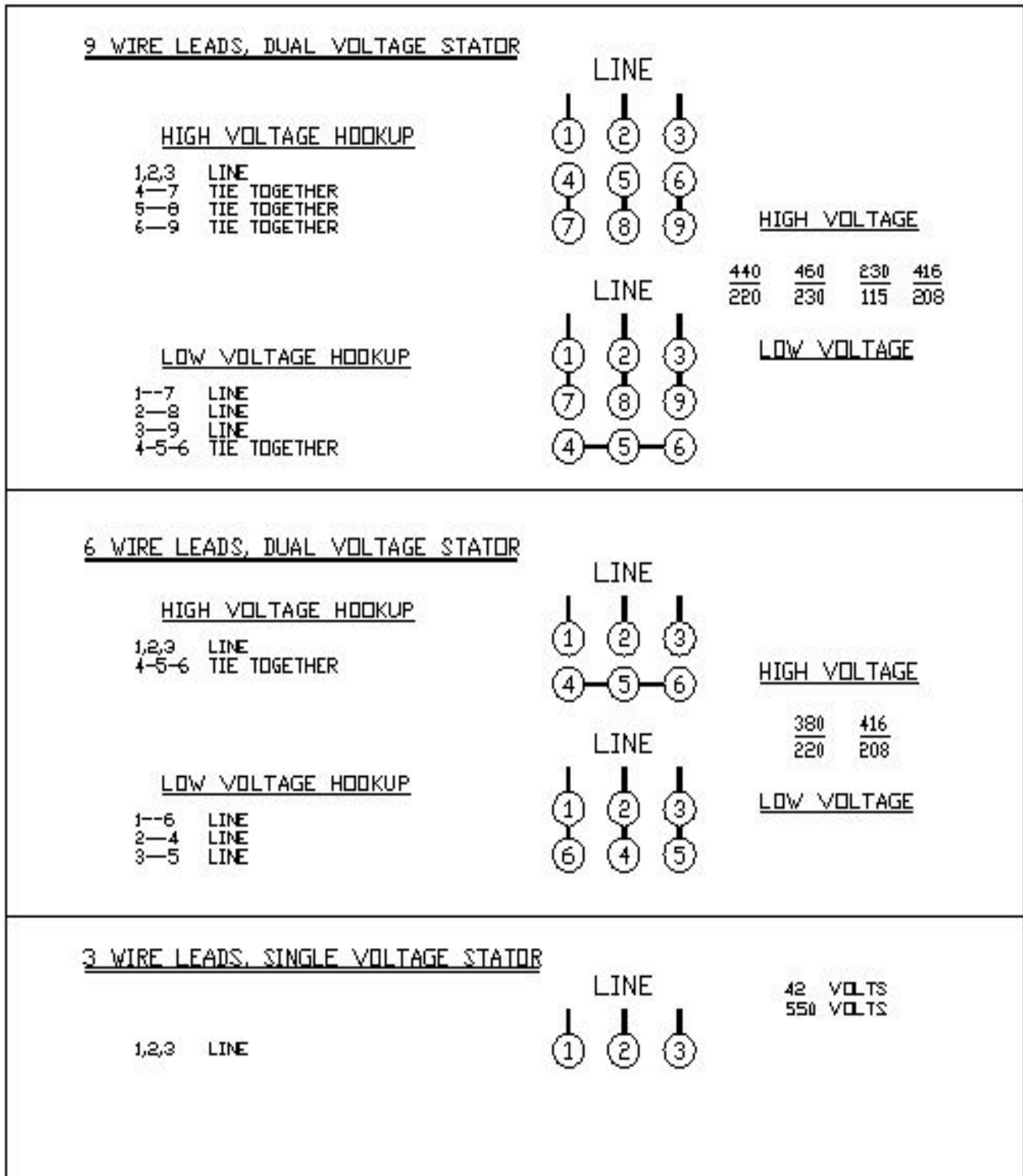

**Figure 20 ELECTRIC MOTOR LEAD HOOKUP DIAGRAM 3 PHASE MOTOR**

[ENGLISH]

## GENERAL INFORMATION

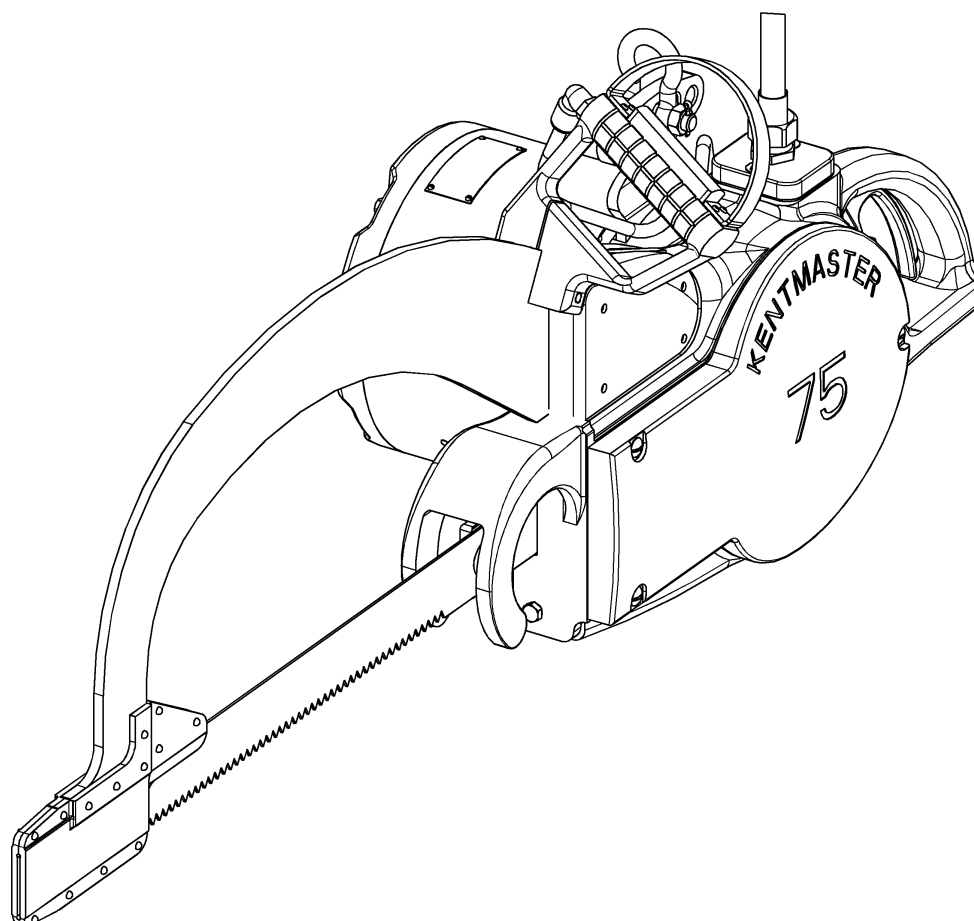

MODEL  
**“75” BEEF SPLITTING SAW (1070000)**

### SERVICE CENTERS

**KENTMASTER EQUIPMENT (AUST)**  
UNIT 2 / 24 CENTRAL COURT  
HILLCREST, QUEENSLAND 4118  
AUSTRALIA

☎ TELEPHONE: + 61 7 3806-8400  
FAX: + 61 7 3806-7933  
E-MAIL: [sales@kentmaster.com.au](mailto:sales@kentmaster.com.au)

**KENTMASTER MFG. CO., INC.**  
1801 SOUTH MOUNTAIN AVE.  
MONROVIA, CALIFORNIA 91016  
UNITED STATES OF AMERICA

☎ TELEPHONE: (626) 359-8888  
FAX: (626) 303-5151

**NOTICE TO EMPLOYER AND PURCHASER OF TOOL**  
**NOTICE TO SAFETY DIRECTOR**

**You have purchased a powerful tool that, if misused, can cause severe injury and harm to your employees. You must instruct your employees in the safe and proper use of this tool and to follow the safety procedures and instructions that have been supplied by the manufacturer of this tool. Please follow the following instructions.**

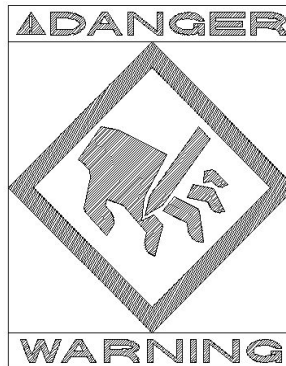

1. Instruct tool operators to test the tool each day before using it to be sure it does not malfunction. Remove and repair any tool that malfunctions.
2. Instruct tool operators to immediately stop using a tool that malfunctions or is defective.
3. Instruct personnel to immediately remove all tools that malfunction. Be sure to disconnect tool from power supply.
4. Instruct all personnel to stay clear of tool, and not to stand or walk in front of, or next to tool when in use.
5. Point out to all personnel the dangers related to the misuse of tool and the importance of following safety procedures and instructions.
6. Do not make, or allow others to make, alterations or modifications to this tool. Replace all lost or illegible labels.
7. Follow all safety, installation and maintenance instructions provided with this tool. Establish proper safety procedures in accordance with local and national requirements to prevent accidental energizing of tool that can cause injuries.
8. If this tool is sold or change in ownership takes place, you must provide the new owner all safety instructions, notices and maintenance instructions you were originally provided. You can obtain additional copies of the instructions from Kentmaster, free of charge upon request.
9. Give copies of instructions to:
  - (A) Tool Operators**
  - (B) Maintenance Supervisor**
  - (C) Clean-up Supervisor**



## GENERAL INFORMATION



COVERING: SAFETY PRECAUTIONS AND PLACING INTO SERVICE  
**ELECTRICAL POWERED BEEF SPLITTING SAW**

**READ THIS MANUAL CAREFULLY BEFORE INSTALLING, OPERATING OR SERVICING  
 THIS TOOL**

IT IS THE RESPONSIBILITY OF THE EMPLOYER TO PLACE THIS INFORMATION INTO THE HANDS OF THE OPERATOR.

### PLACING INTO SERVICE

- |  |   |
|--|---|
|  <b>WARNING</b> | = Hazards or unsafe practices which could result in severe personal injury, death or substantial property damage. |
|  <b>CAUTION</b> | = Hazards or unsafe practices which could result in minor personal injury, product or property damage.            |
|  <b>NOTICE</b>  | = Important installation, operation or maintenance information.   |

- |  |   |
|--|---|
|  <b>WARNING</b> | Installation, adjustment repair and maintenance of this tool must be made by trained and qualified personnel.   |
|  <b>WARNING</b> | Always disconnect power supply from tool before: <ul style="list-style-type: none"> <li>(A) Installing or removing blade from tool.</li> <li>(B) Making repairs or adjustments to the tool.</li> <li>(C) performing maintenance or cleanup work.</li> </ul> |

## INSTALLATION INSTRUCTIONS

-  **WARNING** **ALL ELECTRICAL WIRING MUST BE DONE BY A LICENSED ELECTRICIAN IN ACCORDANCE WITH THE NATIONAL, STATE AND LOCAL ELECTRICAL CODES. (REFER TO NAMEPLATE ON TOOL FOR PROPER POWER CONFIGURATION).**

1. A BALANCER IS REQUIRED FOR OPERATION AND USE OF THIS TOOL. WEIGHT OF TOOL MUST FALL WITHIN WEIGHT RANGE OF BALANCER. "AIR-BALANCERS" WHICH OPERATE ON COMPRESSED AIR, ARE HIGHLY RECOMMENDED FOR USE WITH "75" SAWS. THEY PROVIDE LONG TRAVEL AND VERY SMOOTH, UNIFORM RISE AND FALL. THEY CAN BE INTERFACED WITH THE OPERATION OF THE SAW.
2. INSTALL BALANCER ABOVE WORK AREA. BALANCER MUST HAVE SUFFICIENT VERTICAL TRAVEL SO OPERATOR CAN REACH ENTIRE WORK AREA WITH TOOL WITHOUT STRAIN.
3. ADJUST BALANCER ACCORDING TO THE OPERATOR'S PREFERENCE AND COMFORT.

-  **WARNING** **WE STRONGLY SUGGEST THAT AN ADDITIONAL SAFETY CHAIN BE USED TO CHAIN BALANCER TO OVERHEAD TROLLEY. THIS ADDITIONAL MEASURE OF SAFETY WILL HELP REDUCE INJURIES.**

## OPERATING INSTRUCTIONS

**ONLY TRAINED PERSONNEL ARE TO OPERATE THIS TOOL.**

**WARNING** WITH THE LEFT HAND FIRMLY ON CONTROL HANDLE, PUSH DOWN ON THE REAR HANDLE WITH YOUR RIGHT HAND AND FEEL THE SAW IN THE CROTCH OF THE CARCASS. START THE MACHINE AND CUT THROUGH THE TAILBONE. WHILE CUTTING, MOVE YOUR RIGHT HAND FROM THE REAR HANDLE TO THE TOP OF THE MOTOR HANDLE, STANDING DIRECTLY BEHIND THE SAW. AS YOU CONTINUE DOWN THE CARCASS, PUSH THE SAW ALL THE WAY FORWARD AGAINST THE BACK OF THE CARCASS UNTIL YOU HAVE COMPLETED THE CUT. BY USING THE TRIGGER CONTROL HANDLE WITH YOUR LEFT HAND AND MOTOR HANDLE WITH YOUR RIGHT HAND, YOU CAN MAKE ADJUSTMENTS SO AS TO STAY IN THE CENTER OF THE BACK-BONE BY LIFTING ON ONE SIDE AND PUSHING DOWN ON THE OTHER SIDE. AS THE OPERATOR BECOMES EXPERT WITH THE MACHINE, HE MAY FIND INDIVIDUAL WAYS TO HANDLE THE SAW TO SUIT HIMSELF.

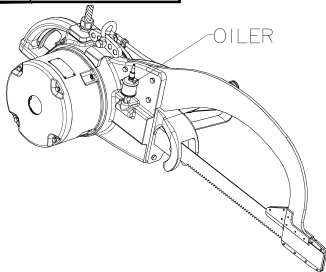
**MAINTENANCE****ONLY TRAINED AND QUALIFIED PERSONNEL ARE TO PERFORM MAINTENANCE AND SERVICE TO THIS TOOL.****WARNING**

TOOL REQUIRES CONTINUOUS LUBRICATION. VERIFY OILER CUP AT THE END OF EACH SHIFT AND ENSURE THAT THE OILER CONTAINS LIGHT-WEIGHT, FOOD-GRADE OIL, ENOUGH TO COVER BOTTOM OF OILER CUP.

OIL CUP LUBRICATES THE SLIDE AND SHOULD BE ADJUSTED AS FOLLOWS:

1. FILL OIL RESERVOIR WITH OIL.
2. RAISE TOP ON-OFF LEVER UPRIGHT TO "ON" POSITION.
3. TURN FLOW ADJUSTMENT NUT CLOCKWISE TO OBTAIN 3-5 DROPS/MIN.
4. TURN LOCKNUT AGAINST FLOW ADJUSTMENT NUT.
5. TURN OILER "ON" (LEVER UPRIGHT) AT BEGINNING OF WORK SHIFT AND DROP LEVER AT END OF WORKSHIFT FOR "OFF" POSITION. KEEP OIL RESERVOIR FULL.

**BLADE REMOVAL AND CLEANING.**

**ALWAYS DISCONNECT POWER SUPPLY FROM TOOL BEFORE INSTALLING OR REMOVING BLADE FROM TOOL.**

**WARNING** ALWAYS WEAR WIRE MESH GLOVES WHEN INSTALLING OR REMOVING BLADES FROM TOOL.

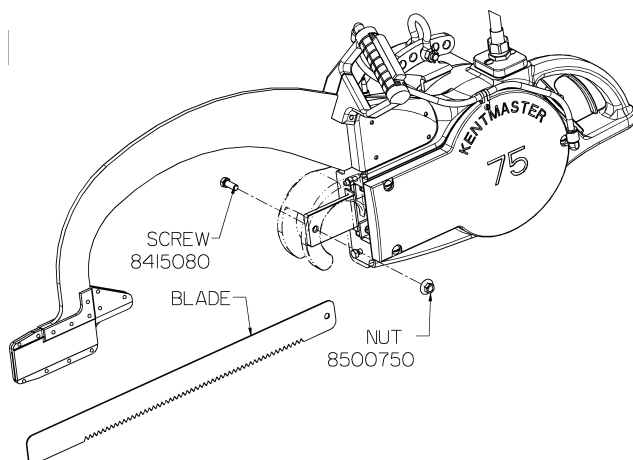

TO INSTALL SAW BLADE, TO REMOVE SAW BLADE FROM THE MACHINE, REMOVE NUT #8500750 AND SCREW #8415080. REMOVE THE BLADE. TO INSTALL THE BLADE FOLLOW ABOVE PROCEDURE IN REVERSE.



**DECLARATION OF CONFORMITY****DECLARATION OF CONFORMITY**DECLARATION DE CONFORMITE -DECLARACION DE CONFORMIDAD- ERKLARUNG BEZUGLICH EINHALTUNG DER VORSCHRIFTEN  
DICHIARAZIONE DI CONFORMITA . CONFORMITEITSVERKLARING**MANUFACTURED BY:**FABRIQUE PAR:  
FABRICADA POR:  
HERGESTELLTVON:  
FABBRICATO DA:  
VERVAARDIGD DOOR:**KENTMASTER MFG CO., INC.**1801 SOUTH MOUNTAIN AVE.  
MONROVIA, CALIFORNIA 91016  
UNITED STATES OF AMERICA  
TELEPHONE (626) 359-8888 FAX (626) 303-5151**TYPE / SERIES: BEEF SPLITTING SAW**TYPE / SERIE:  
TIPO / SERIE:  
TYP / SERIE:  
TIPO / SERIE:  
TYPE / SERIE:**MODEL: 75**MODELE:  
MODELO:  
MODELL:  
MODELLO:  
MODEL:**SERIAL NO. RANGE: XXXXX**

N SERIE: • GAMA DE No. DE SERIE: • SERIEN-NR.-BEREICH: • NUMERI DI SERIE: • SERIENUMMERS:

**This product complies with the following European Community Directives:**Ce produit est conforme aux directives de la Communauté européenne suivantes:  
Este producto cumple con las siguientes Directrices de la Comunidad Europea:  
Dieses Produkt erfüllt die folgenden Vorschriften der Europäischen Gemeinschaft:  
Questo prodotto e conforme alle seguenti direttive CEE:  
Dit produkt voldoet aan de volgende EG-richtlijnen:**89/392/EEC, 91/368/EEC, 93/44/EEC, 93/68/EEC****The following Standards were used to verify compliance with the Directives:**Les normes suivantes ont été utilisées pour vérifier la conformité avec les Directives:  
Las siguientes Normas se usaron para verificar el cumplimiento de las Directrices:  
Folgende Normen wurden angewandt, um Erfüllung der Vorschriften zu bestätigen:  
Per verificare la conformità del prodotto alle direttive sono stati usati i seguenti standard:  
De volgende normen zijn gebruikt om naleving van de richtlijnen te bevestigen:**EN 292****Approved by:** \_\_\_\_\_**Date:** AUG - 1 - 1995RALPH KARUBIAN MONROVIA, CA. U.S.A  
(Engineering Manager) (Directeur technique) (gerente de ingeniería) (verantwortlicher Konstruktionsleiter) (Responsabile tecnico) (ondersteunend technisch mangar)

## Kentmaster Worldwide Location

Kentmaster Equipment (Aust) PTY.LTD.

Unit 2,24 Central Court

Hillcrest, Qld. 4118

Australia

Telephone: (07) 3806-8400

Fax: (07) 3806-7933

[Australia@Kentmaster.com.au](mailto:Australia@Kentmaster.com.au)

---

Kentmaster do Brasil, Ltda.

Av. Dr. Joao Teodoro No. 805

Bairro De Vila Rezende

13405-240 Piracicaba, SP,

Brazil

Telephone #1: (019) 3 413 3113

Telephone #2: (019)983-4973

Fax: (019) 3 413 3113

[Brazil@Kentmaster.com](mailto:Brazil@Kentmaster.com)

---

Kentmaster (IRL) LTD.

Benamore, Dublin Road.

Roscrea,

CO, Tipperary,

Ireland

Telephone: (353) 0505-23292

Fax: (353) 0505-23299

[Ireland@Kentmaster.com](mailto:Ireland@Kentmaster.com)

---

Kentmaster Equipment (NZ) LTD.

5 Cooper Street

Havelock North

New Zealand

Telephone #1: (64) 6 8777 857

Telephone #2: 0800 KENTMASTER

Fax: (64) 6 8777 858

[NewZealand@Kentmaster.com](mailto:NewZealand@Kentmaster.com)

Kentmaster South Africa (PTY) LTD.

Johannesburg - S. Africa

Unit 54 Sunnyrock Park

Sunrock Close, Germiston

South Africa

Telephone: (27) 11-455-3748

Fax: (27) 11-455-3749

[SouthAfrica@Kentmaster.com](mailto:SouthAfrica@Kentmaster.com)

---

Kentmaster (UK ) LTD.

Unit 16 Avonbank Ind. Centre

West Town Rd, Avonmouth-Bristol,

BS11 9DE

England

Telephone: (44) 117-923-5035

Fax: (44)-117-932-9010

[UK@Kentmaster.com](mailto:UK@Kentmaster.com)

---

Kentmaster Mfg. Co., Inc.

1801 South Mountain Ave.

Monrovia, CA, 91016

USA

Telephone #1: (626) 359-8888

Telephone #2: (800) 421-1477

Fax: (626) 303-5151

[info@Kentmaster.com](mailto:info@Kentmaster.com)

---

Kentmaster Omaha

4417 South 139th Street

Omaha, NE, 68137

USA

Telephone #1: (402) 896-3355

Telephone #2: (800) 367-3181

Fax: (402) 896-3311

[Omaha@Kentmaster.com](mailto:Omaha@Kentmaster.com)

**INDEX**

<b>OPERATING AND SAFETY INSTRUCTIONS</b> .....	<b>2</b>
<b>SERVICE</b> .....	<b>3</b>
<b>PARTS BOOK</b> .....	<b>4</b>
<b>“75” MAIN ASSEMBLY</b> .....	<b>4</b>
Instructions for replacement of yoke end.....	6
<b>MOTOR ASSEMBLY</b> .....	<b>7</b>
<b>POWER SUPPLY</b> .....	<b>9</b>
<b>FRONT HANDLE</b> .....	<b>11</b>
<b>FRAME ASSEMBLY</b> .....	<b>12</b>
<b>LUBRICATING FELT INSTALLATION</b> .....	<b>14</b>
DRIP FEED OIL CUP ADJUSTMENT.....	15
<b>WIRING DIAGRAMS</b> .....	<b>16</b>
3-PHASE, DIFFERENT CONTROL AND MOTOR VOLTAGE .....	16
3-PHASE, SAME CONTROL AND MOTOR VOLTAGE.....	17
SINGLE PHASE, 230 VOLTS.....	18
<b>GENERAL INFORMATION</b> .....	<b>23</b>
<b>INSTALLATION INSTRUCTIONS</b> .....	<b>23</b>
<b>OPERATING INSTRUCTIONS</b> .....	<b>23</b>
<b>MAINTENANCE</b> .....	<b>24</b>
<b>DECLARATION OF CONFORMITY</b> .....	<b>25</b>
<b>Kentmaster Worldwide Location</b> .....	<b>26</b>
<b>INDEX</b> .....	<b>27</b>
<b>FIGURES - INDEX</b> .....	<b>27</b>

**FIGURES - INDEX**

Figure 1 MODEL “75” .....	4
Figure 2 BOM FOR MODEL “75” .....	5
Figure 3 Yoke end replacement .....	6
Figure 4 MOTOR ASSEMBLY .....	7
Figure 5 BOM FOR MOTOR ASSEMBLY .....	8
Figure 6 1071630 & 1071640 : ROTOR –SHAFT ASSEMBLY .....	9
Figure 7 1002422: POWER SUPPLY, NON 42V, 3 PHASE.....	9
Figure 8 1002430: POWER SUPPLY, 42V, 3 PHASE .....	10
Figure 9 1072429: POWER SUPPLY, 115/230V, SINGLE PHASE .....	10
Figure 10 1710310: ELECTRIC HANDLE .....	11
Figure 11 1070011: FRAME ASSEMBLY .....	12
Figure 12 BOM FOR FRAME ASSEMBLY .....	13
Figure 13 1202470: HANGER ASSEMBLY .....	13
Figure 14 1071320: LUBRICATING FELT SET .....	14
Figure 15 Oil cup adjustment.....	15
Figure 16 WIRING DIAGRAM – different control and motor voltage.....	16
Figure 17 WIRING DIAGRAM – same control and motor voltage .....	17
Figure 18 WIRING DIAGRAM – SINGLE PHASE, 230V .....	18
Figure 19 WIRING DIAGRAM – SINGLE PHASE, 115V .....	19
Figure 20 ELECTRIC MOTOR LEAD HOOKUP DIAGRAM 3 PHASE MOTOR .....	20