

JIALIFT®



www.jialift.com.au

CL1030J Full Electric Walkie Stacker

- 1000kg Capacity; Max Lifting Height - 3000mm
- Walk-behind operate no license required
- Safe, reliable, sustainable and low maintenance

CE

JIALIFT Full Electric Walkie Stacker (1T/3000mm)

JIALIFT electric economy stacker CL10J series offers an attractive appearance, convenient operation, and features. It offers a number of **advantages**:

- Walk-behind operate no license required
- Control panel: Red Stop Bottom, Key Switch and Battery Indicator on the Right. In-built charger on the Left
- The in-built charger is the single phrase (wall plug) that can be easily charged
- The side-driven design effectively reduces the size of the operation channel.
- With a small turning radius, this stacker is suitable for narrow spaces.
- Though it is an economical power stacker, it is still equipped with a high-power and high-performance lifting pump station, which ensures the goods lifting.
- Adjustable driving speed switch
- The turtle speed switch on the handle makes low-speed control more precise.
- Germany imported waterproof micro-switches are applied in cold, damp, dusty and other harsh environments.
- YONGCI motor drive system is small in size, lightweight, low loss and high in efficiency.

Standard Equipment:

Also Included in our Offer: Battery and Charger

Warranty: 5 Years refer to the JIALIFT warranty terms and conditions



JIALIFT AUSTRALIA PTY LTD

Call Us: 1300 000 168 Email: sales@jialift.com.au

46-48 Geddes St, Mulgrave VIC 3170 Open at 8:30 am - 5:30 pm, Monday-Friday

www.jialift.com.au

JIALIFT®

MATERIAL HANDLING EQUIPMENT

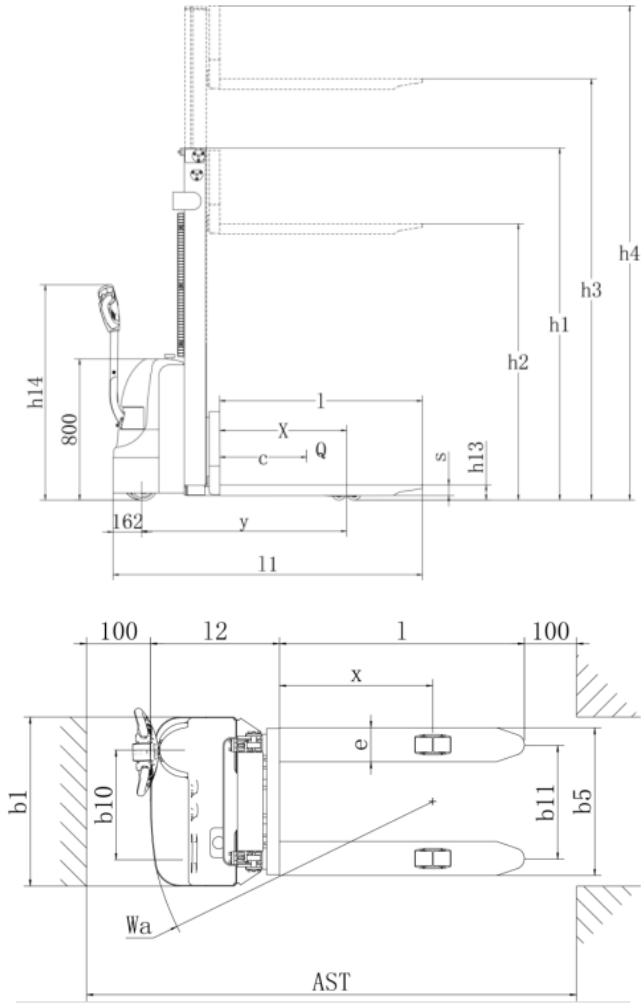

JIALIFT AUSTRALIA PTY LTD

Call Us: 1300 000 168 Email: sales@jialift.com.au

46-48 Geddes St, Mulgrave VIC 3170 Open at 8:30 am - 5:30 pm, Monday-Friday



www.jialift.com.au

Distinguishing mark		
Model designation		CL1030J
Load capacity	kg	1000
Load capacity on max. Height	kg	700
Max lifting height	mm	3000
Load center distance	mm	600
Weight		
Service weight	kg	465
Dimensions		
Fork length	mm	1150
Single fork width	mm	160
Overall fork width	mm	570/695
Lowered fork height	mm	86
Fixed leg length	mm	928
Single fixed leg width	mm	124
Inside width between fixed legs	mm	262/387
Outside width between fixed legs	mm	534/659
Turning radius	mm	1336
Aisle width for pallets 1000 × 1200 crossways	mm	2074
Aisle width for pallets 800 × 1200 lengthways	mm	2040
Overall length	mm	1755
Overall width	mm	795
Extended mast height	mm	3424
Lowered mast height	mm	1994
Types, Chassis		
Front wheel size, number	mm	80x70, 4
Rear wheel size, number	mm	210x70, 1
Balance wheel size, number	mm	150x58, 1
Performance data		
Driving speed, laden/ unladen	km/ h	4/4.2
Lifting speed, laden/ unladen	mm/ s	100/155
Lowering speed, laden/ unladen	mm/ s	150/130
Electric-engine		
Drive motor rating	kW	0.75
Lift motor rating	kW	2.2
The controller		24V/90A
The charger		24V/10A
Battery voltage/nominal capacity		2x12V/100AH
Battery dimensions	mm	260/169/215



JIALIFT AUSTRALIA PTY LTD

Call Us: 1300 000 168 Email: sales@jialift.com.au

46-48 Geddes St, Mulgrave VIC 3170 Open at 8:30 am - 5:30 pm, Monday-Friday

www.jialift.com.au