

HYWORTH®

FORKLIFTS

Hyworth 1.5T and 2T Lithium Electric Pallet Jack

	1.2	Model Number		H15PM-LI	H20PM-Li
	1.3	Type of operation		Pedestrian	Pedestrian
	1.4	Rated Capacity / rated load	Q (kg)	1500	2000
	1.5	Lift height	c (mm)	200	200
	1.6	Service weight with battery	(kg)	142	146
	1.7	Load centre	c (mm)	600	600
	1.8	Axle centre to fork face	x (mm)	944	944
	1.9	Wheelbase	y (mm)	1243	1243
	1.10	Controller		CURTIS	CURTIS
		WHEELS			
	2.1	Wheel type		Polyurethane	Polyurethane
	2.2	Driving wheel size	ø x w (mm)	ø 210 x 70	ø 210 x 70
	2.3	Loading wheel size	ø x w (mm)	ø 80 x 60	ø 80 x 60
	2.4	Wheels, number front / rear (x = driven)		1 x /4	1 x /4
	2.5	Track width, rear, loading side	b11 (mm)	400/535	400/535
		DIMENSIONS			
	3.1	Overall length	l1 (mm)	1603	1603
	3.2	Length to fork face	l2 (mm)	453	453
	3.3	Overall width	b1 (mm)	550/685	550/685
	3.4	Fork dimensions	s/e/l (mm)	50/150/1150	50/150/1150
	3.5	Width of forks	b5 (mm)	550/685	550/685
	3.6	Lowered height	h13 (mm)	85	85
	3.7	Minimum ground clearance	m2 (mm)	35	35
	3.8	Height drawbar in driving position min / max	h14 (mm)	740/1160	740/1160
	3.9	Aisle width with pallet 1000 x 1200 across forks	Ast (mm)	1804	1804
	3.10	Aisle width with pallet 800 x 1200 along forks	Ast (mm)	1854	1854
	3.11	Minimum turning radius	Wa (mm)	1398	1398
		PERFORMANCE			
	4.1	Travel speed with / without load	(km/h)	4.2/4.5	4.2/4.5
	4.2	Max Gradeability laden / unladen	(%)	5/10	6/10
	4.3	Service brake type		Electromagnetic	Electromagnetic
		DRIVE AND BATTERY			
	5.1	Drive motor, output s2 60 min	(kW)	0.75	0.75
	5.2	Lift motor rating at s3 15%	(kW)	0.80	0.80
	5.3	Battery according to din 43531 / 35 / 36 a,b,c no		no	no
	5.4	Battery voltage / rated capacity	(V/Ah)	24/40 (Lithium iron phosphate)	48/20 (Lithium iron phosphate)
	5.5	Battery weight (+ 5%)	(kg)	10.2	10.2
	5.6	Charger specification		24v / 10A (Lithium iron phosphate)	48v / 5A (Lithium iron phosphate)
		OTHERS			
	6.1	Type of drive control		DV	DC
	6.2	Sound pressure level at drivers' ear	(dBB(A))	< 70	< 70
	6.3	Steering type		Mechanical	Mechanical

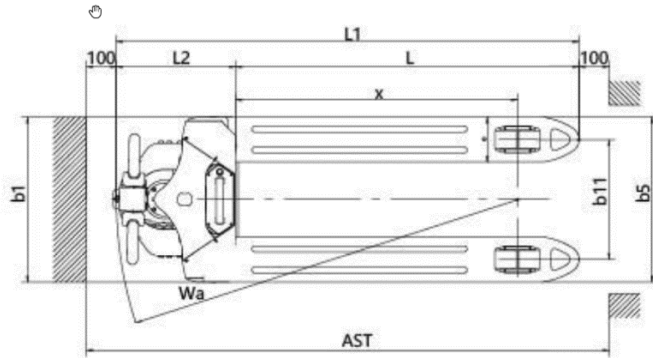
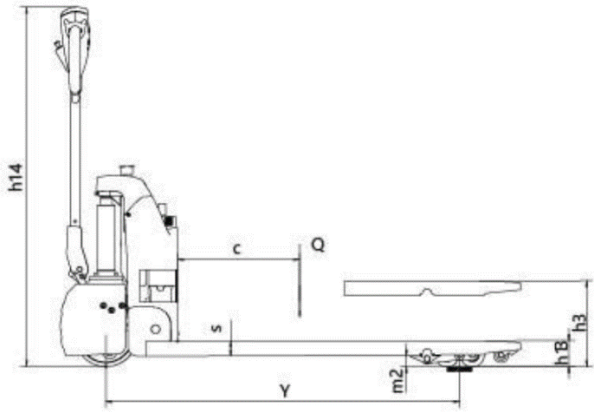

HYWORTH®

F O R K L I F T S

Address: 2/12 Weld Street PRESTONS NSW 2170

Phone: 1300 HYWORTH (1300 499 678)

Email: info@hyworthforklifts.com.au

Web: www.hyworthforklifts.com.au