



M12

Vertical electric tug

M12

Z178.720



- For loads up to 1.500 kg.
- Versatile and compact.
- Interchangeable battery packs.
- 5-levels speed adjustment.
- Wide range of accessories and connections.
- Optional remote control driving.

👁 **Front View**



👁 **Side View**



👁 **Rear View**



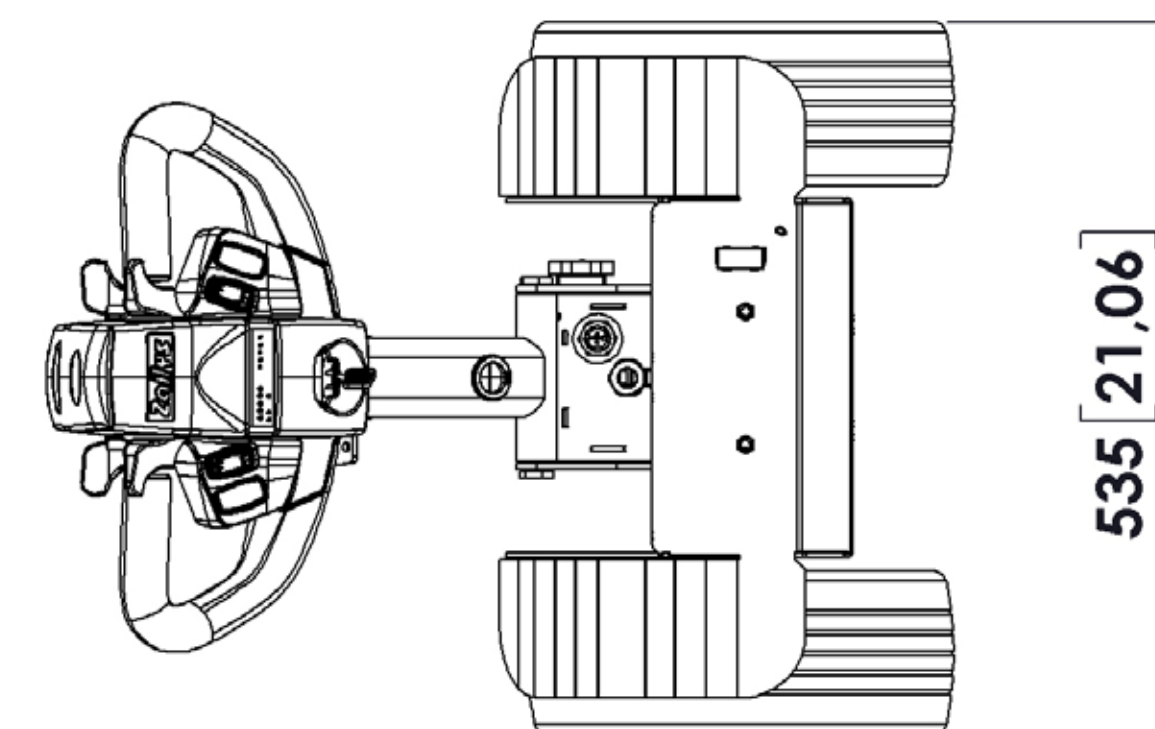
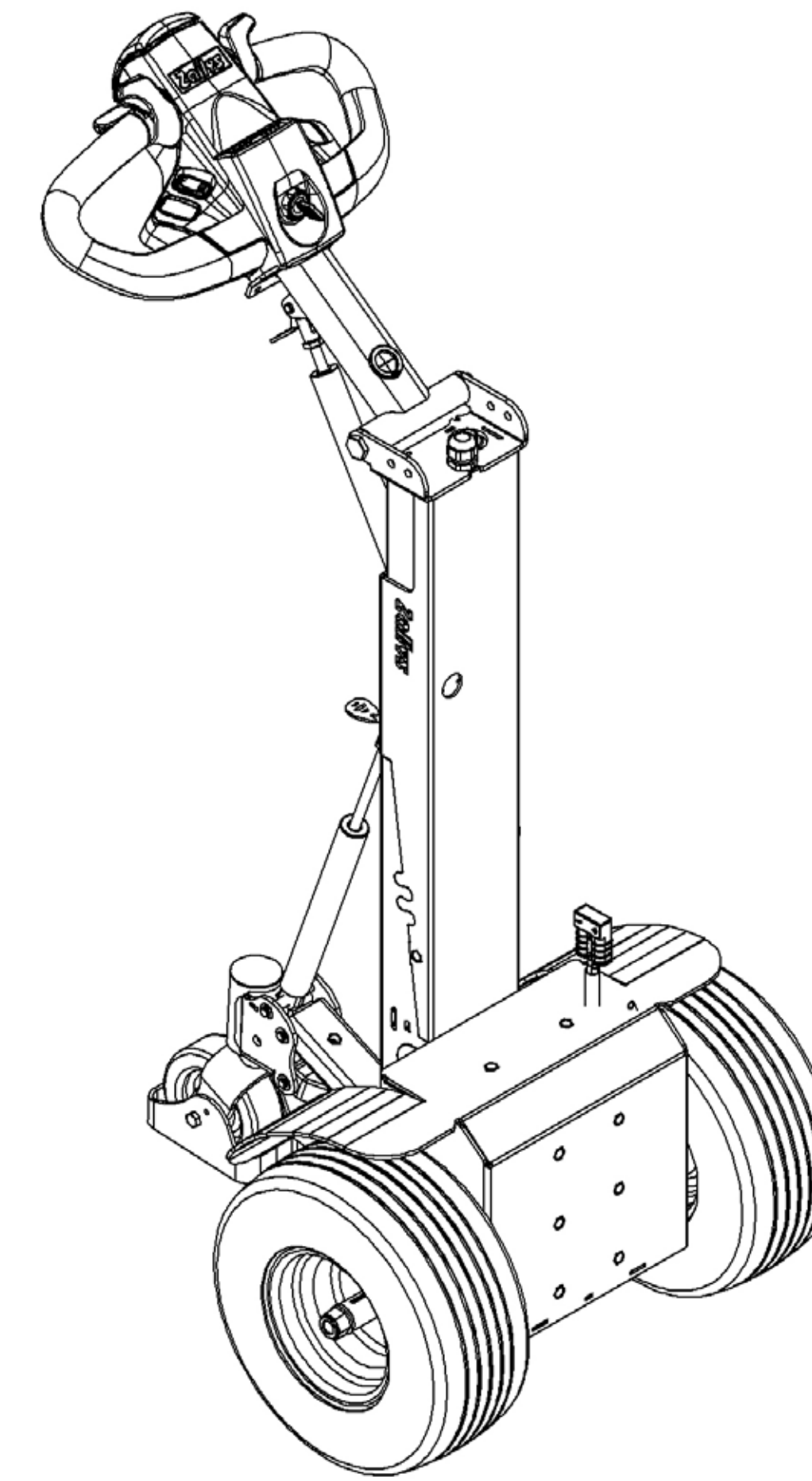
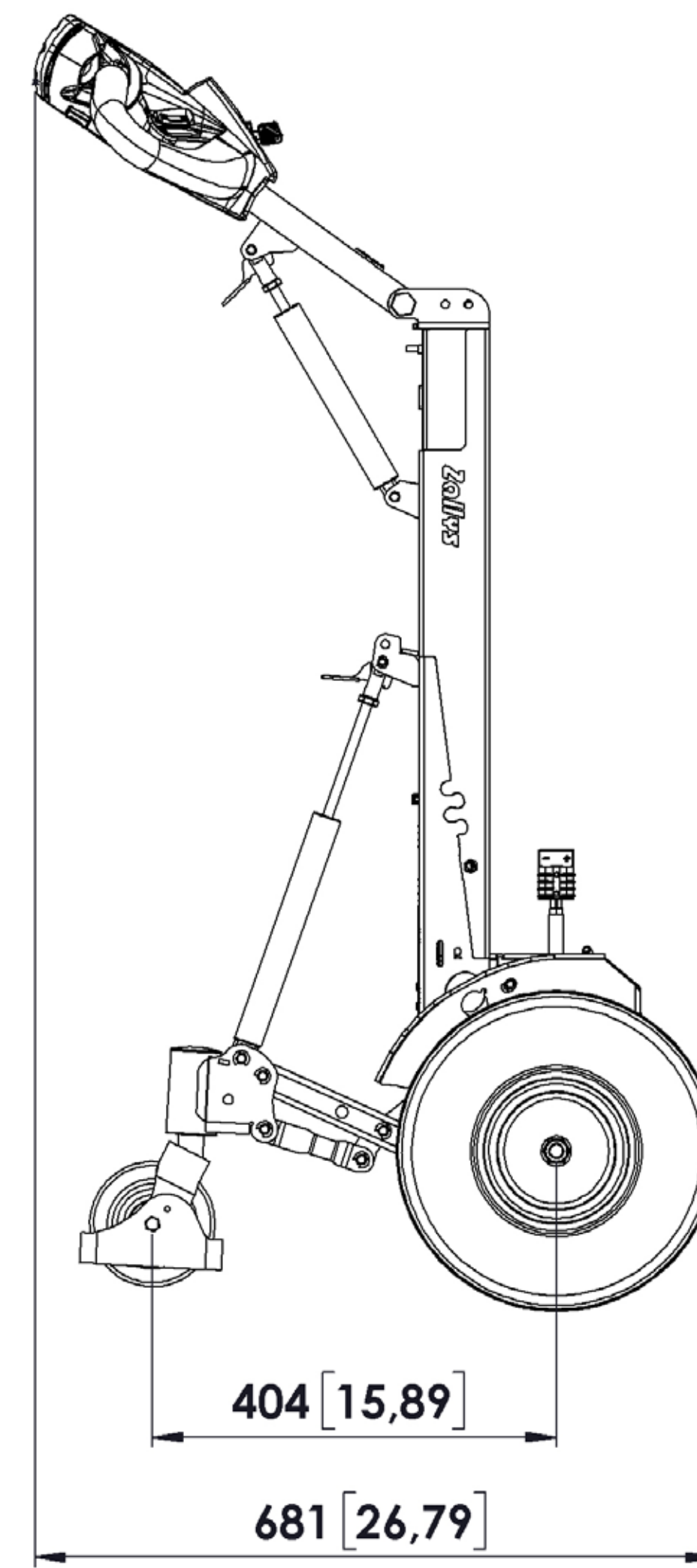
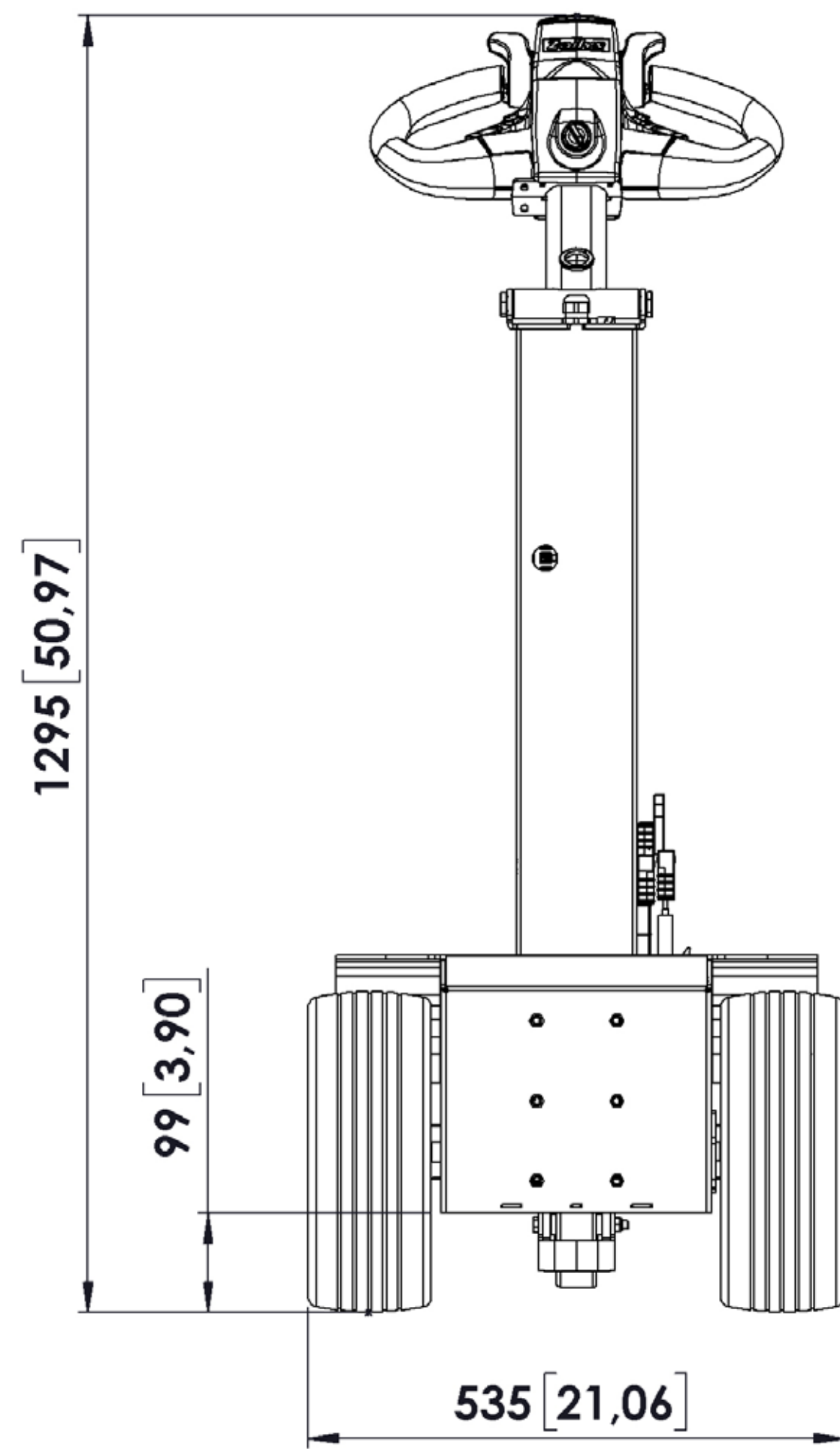

Performances on slopes

While the force expressed in N at the hook remains unchanged, the following circumstances **may affect the towing capacity expressed in kg**:

- **type of ground** on which the towing is performed;
- towing on **flat ground or on a slope**;
- use (or not) of **ballasts**;
- **type of wheels** mounted on the vehicle and on the trailer.

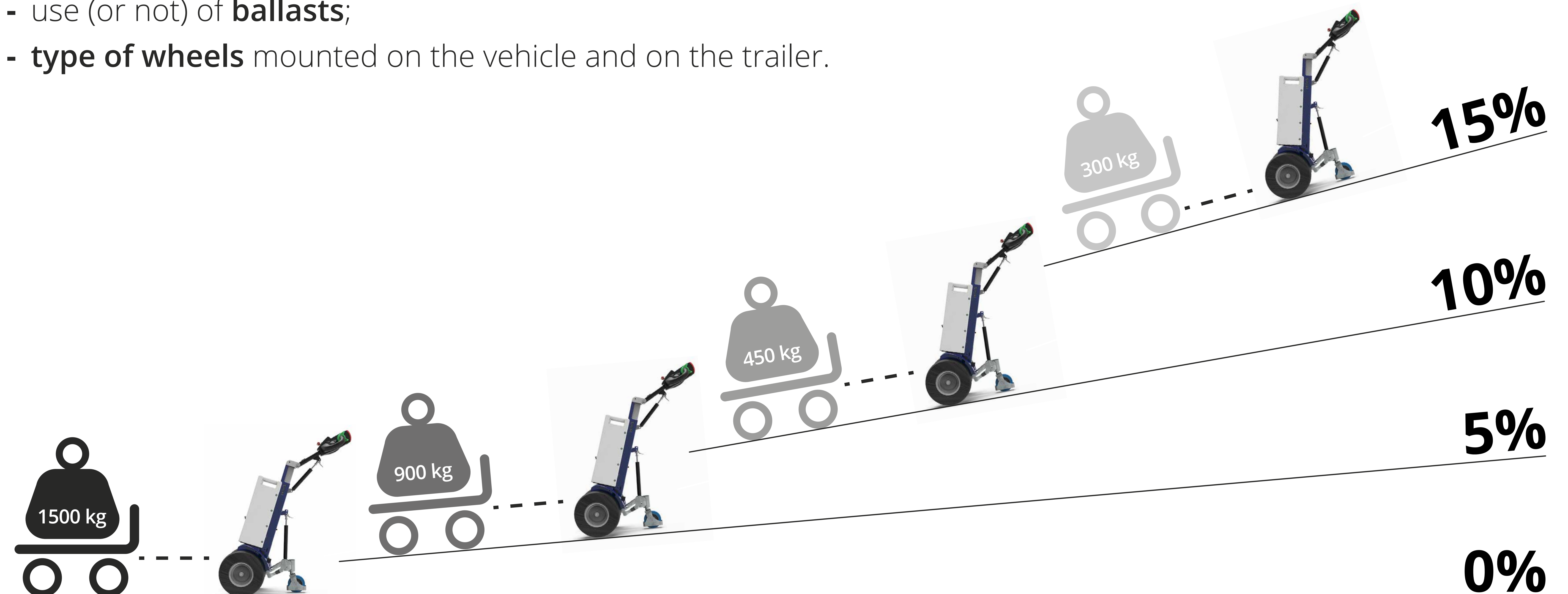

Ergonomic driving

Zallys' tillerhead has been conceived and produced to make the use of the machine more ergonomic for the operator, guaranteeing the right **comfort while driving during the work shift**.

Its ergonomic design allows to have **all the driving controls at your fingertips**, the display with the battery charge level and the power key for an easy and fast ignition.

The structure is made of **resistant materials** in case of accidental bumps.

Power key

5 speed selection

Anti-crush reverse button



..... Dashboard

..... Acoustic alarm

..... Mantained action drive controls

5 levels speed adjustment

On the new M12 tillerhead by Zallys is mounted **as standard** a button for the adjustment of the speed of the machine. By clicking it, at each click you switch to the next level. This allows a fast and easy selection of the correct speed based on the kind of manoeuvre. **The Flex-to-Go system** has been studied to give a better maneuverability in confined spaces and more speed on the longer journeys.

Each click adds **20% more speed**.

Speed ramp:

20% - 40% - 60% - 80% - 100%

Once the maximum speed is reached, by pressing the button again it returns to 20%.

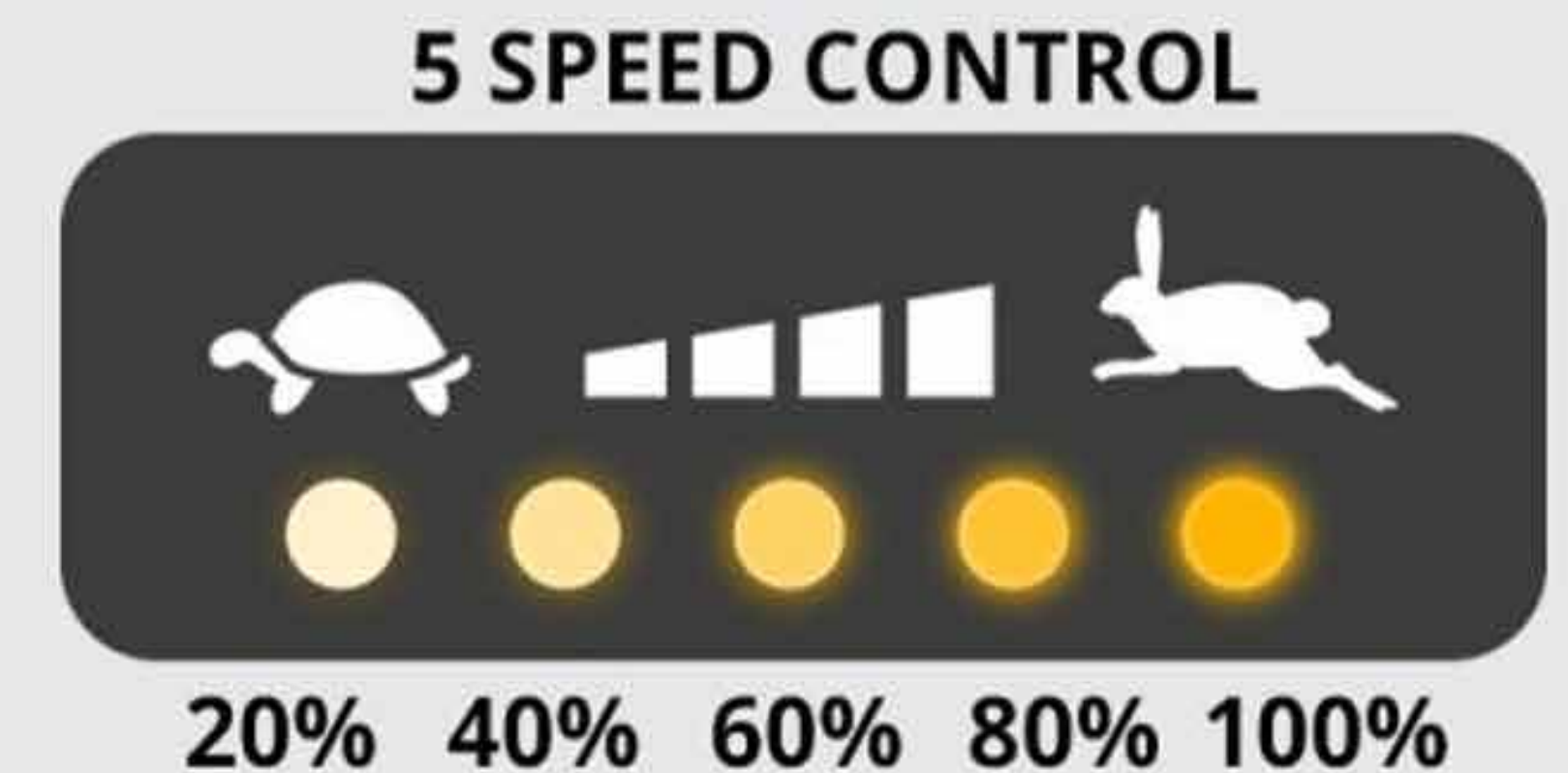

Interchangeable battery packs 24/7

Battery packs are lightweight and easily **interchangeable** in order to cover several work shifts: when one is discharged you can put it in charge and immediately replace it with a fully charged one. This way, the machine is always operating! Moreover, **different amperages** are available according to your needs: 33Ah, 45Ah AGM or 40Ah Lithium



33Ah - AGM



45Ah - AGM



40Ah - Lithium

Modular ballast system

Zallys modular system guarantees **maximum flexibility** on increasing the vehicle's performances. With just **4 kg unit weight**, single ballasts are lightweight and can be equipped **without physical effort by the operator**, while maintaining all their effectiveness.

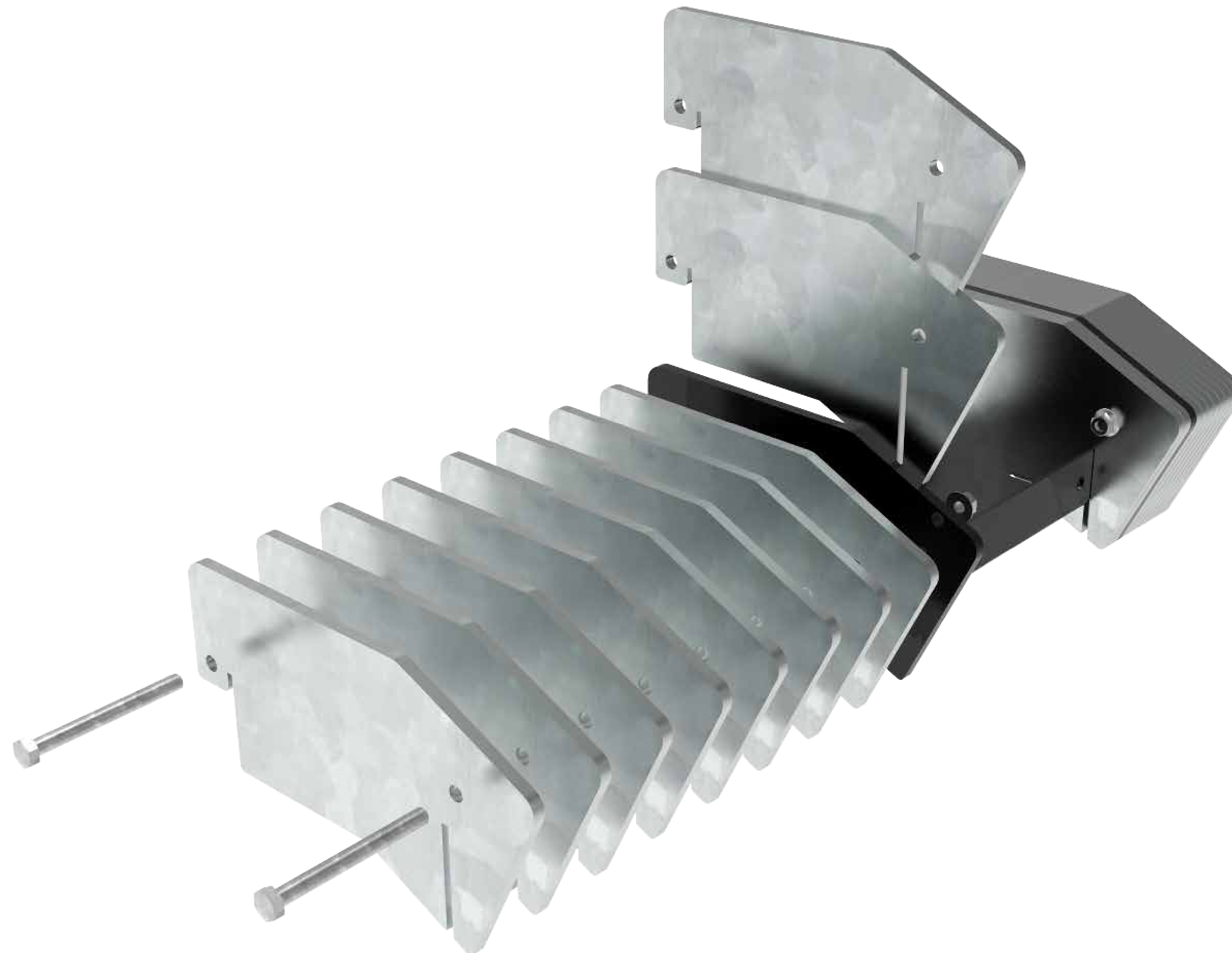

Manual Hitches



Example picture

PROS

- Easy and quick connection
- Cheaper price

CONS

- Can shift sideways along the frame
- In the event of potholes, rails or doorsteps it could come off the bar

Electric Hitches



Example picture

PROS

- Easy and quick connection
- With just 1 accessory it is possible to clamp frames of different measures
- The hitch is controlled by commands on the tiller head

CONS

- Needs a configuration kit
- Higher total cost compared to the standard machine configuration (although, it is a very good investment on the long run because it speeds up the coupling and uncoupling process)
- More delicate compared to the hydraulic one

Hydraulic Hitches



Example picture

PROS

- Easy and quick connection
- With just 1 accessory it is possible to clasp frames of different measures
- Coupling with very strong clamp, useful for applications in which the hook has to withstand stress/bumps.
- More compact compared to the electric clamp hitch (lower and narrower)

CONS

- Higher total price compared to the standard machine configuration
- Even though the effort is minimal, the pump is manual



• • • the passion for moving

Applications

on various production sectors



INDUSTRIAL LOGISTICS

Zallys
... the passion for moving





TEXTILE INDUSTRY

Zolllys
... the passion for moving





METALLURGICAL INDUSTRY

Zallys
... the passion for moving



GLASS INDUSTRY

Zallys
... the passion for moving



HOSPITALS

Zolllys
... the passion for moving





• • • the passion for moving

Zallys srl srl - Via Palazzina 1, Sarcedo
36030 (VI) - Italia

Contacts:

sales@zallys.com
+39 0445 366785

Web site:

www.zallys.com

