

**BRX**

 **DROP-IN**

 ***DROP-IN***

**BRX**

**POZZETTI GELATO & BAR TECHNOLOGY**

**UNA VASCA PER OGNI LOCALE**  
*EACH PLACE HAS ITS OWN DROP-IN*

DUAL

DUAL BT / FREEZER

NEA

P60, P80

P60 BT / FREEZER

P60 COCKTAIL

FRUTTINI / TOPPINGS

LA GAMMA DROP-IN DI BRX RAPPRESENTA IL PRODOTTO IDEALE PER REALIZZARE BANCHI ESPOSITIVI MILLEUSI CON UN LOOK MINIMALE ED ELEGANTE, PERFETTE PER OGNI AMBIENTAZIONE E FORMAT.

BRX'S DROP-IN RANGE OFFERS THE PERFECT SOLUTION FOR MULTIPURPOSE DISPLAY COUNTERS WITH A MINIMALIST, ELEGANT LOOK, PERFECT FOR ANY ENVIRONMENT AND FORMAT.

# 03 LA GAMMA DROP-IN DROP-IN RANGE

DROP IN

DROP IN



## DUAL

Visibilità e flessibilità progettuale:

- . bassa temperatura
- . freddo statico
- . freddo ventilato
- . freddo ventilato per pralineria
- . doppio impianto (freddo ventilato/caldo secco)

Visibility and design flexibility:

- . freezer
- . static cold
- . ventilated cold
- . ventilated cold for chocolate
- . dual mode function (ventilated cold /dry-heat)



## NEA

L'eleganza e la funzionalità della pasticceria canalizzabile:

- . freddo ventilato
- . freddo ventilato per pralineria
- . doppio impianto (freddo ventilato/caldo secco)

The elegance and functionality of the multiplexing pastry display:

- . ventilated cold
- . ventilated cold for chocolate
- . dual mode function (ventilated cold /dry-heat)

## P60 - P80

Linea versatile con una variante di forme e usi:

- . bassa temperatura
- . freddo statico
- . freddo statico a contatto
- . freddo ventilato
- . doppio impianto (freddo ventilato/caldo secco)
- . caldo secco
- . bagno maria
- . cocktail

Versatile line with a variety of shapes and uses:

- . freezer
- . static cold
- . static contact cold
- . ventilated cold
- . dual mode function (ventilated cold / dry-heat)
- . dry-heat
- . bain-marie
- . cocktail station



## FRUTTINI / TOPPINGS:

Piccole e versatili:

- . freddo statico
- . caldo secco
- . neutre

Small and versatile:

- . static cold
- . dry-heat
- . neutral



Tutte le vasche sono disponibili anche nella opzione banco  
All the drop-in are available also in the option full counter

Ogni vasca ha la sua profondità / Each drop-in has its own depth

- Dual 700 mm
- Nea 850 mm
- P60 600 mm
- P80 800 mm

(Attenzione che queste però sono le misure dei banchi!!!) All the drop-in are available also in the option full counter

# 03 MULTIFUNZIONI MULTIPLE USES

DROP IN



DROP IN

## DUAL

## NEA

## P60

## P80

## VASCHE FRUTTINI TOPPINGS TUBS

<b>BASSA TEMPERATURA</b> <i>FREEZER</i>	●	—	●	●	●
<b>FREDDO STATICO</b> <i>STATIC COLD</i>	—	—	●	●	—
<b>FREDDO STATICO A CONTATTO</b> <i>STATIC COLD CONTACT</i>	●	●	●	●	—
<b>VASCA FREDDO VENTILATO / CALDO SECCO</b> <i>COLD VENTILATED / DRY HOT TUB</i>	●	●	●	●	—
<b>FREDDO VENTILATO</b> <i>VENTILATED COLD</i>	—	—	—	—	●
<b>FREDDO VENTILATO PER PRALINERIA</b> <i>VENTILATED COLD FOR CHOCOLATE</i>	—	●	●	●	—
<b>DOPPIO IMPIANTO (FREDDO VENTILATO / CALDO SECCO)</b> <i>DUAL MODE FUNCTION (VENTILATED COLD / DRY-HEAT)</i>	—	—	●	●	—
<b>CALDO SECCO</b> <i>DRY-HEAT</i>	—	—	●	—	—
<b>BAGNO MARIA</b> <i>BAIN-MARIE</i>	●	—	●	—	—
<b>COCKTAIL</b> <i>COCKTAIL</i>	—	—	●	—	—
<b>NEUTRA</b> <i>NEUTRAL</i>	●	●	—	—	—
<b>VASCA NEUTRA</b> <i>NEUTRAL TUB</i>	—	●	—	—	●
<b>VASCA NEUTRA COIBENTATA</b> <i>INSULATED NEUTRAL TUB</i>	—	—	—	—	●

● DISPONIBILE  
AVAILABLE

— NON DISPONIBILE  
NOT AVAILABLE

Tutte le vasche sono disponibili anche nella opzione banco  
All the drop-in are available also in the option full counter

03 ???????  
??????

DROP IN

DROP IN

**Una gelateria da banco ideale per l'esposizione  
e la conservazione di torte gelato, stecchi e ghiaccioli.**

*An ice-cream counter, ideal to display and to store ice-cream  
cakes, sticks and popsicles.*

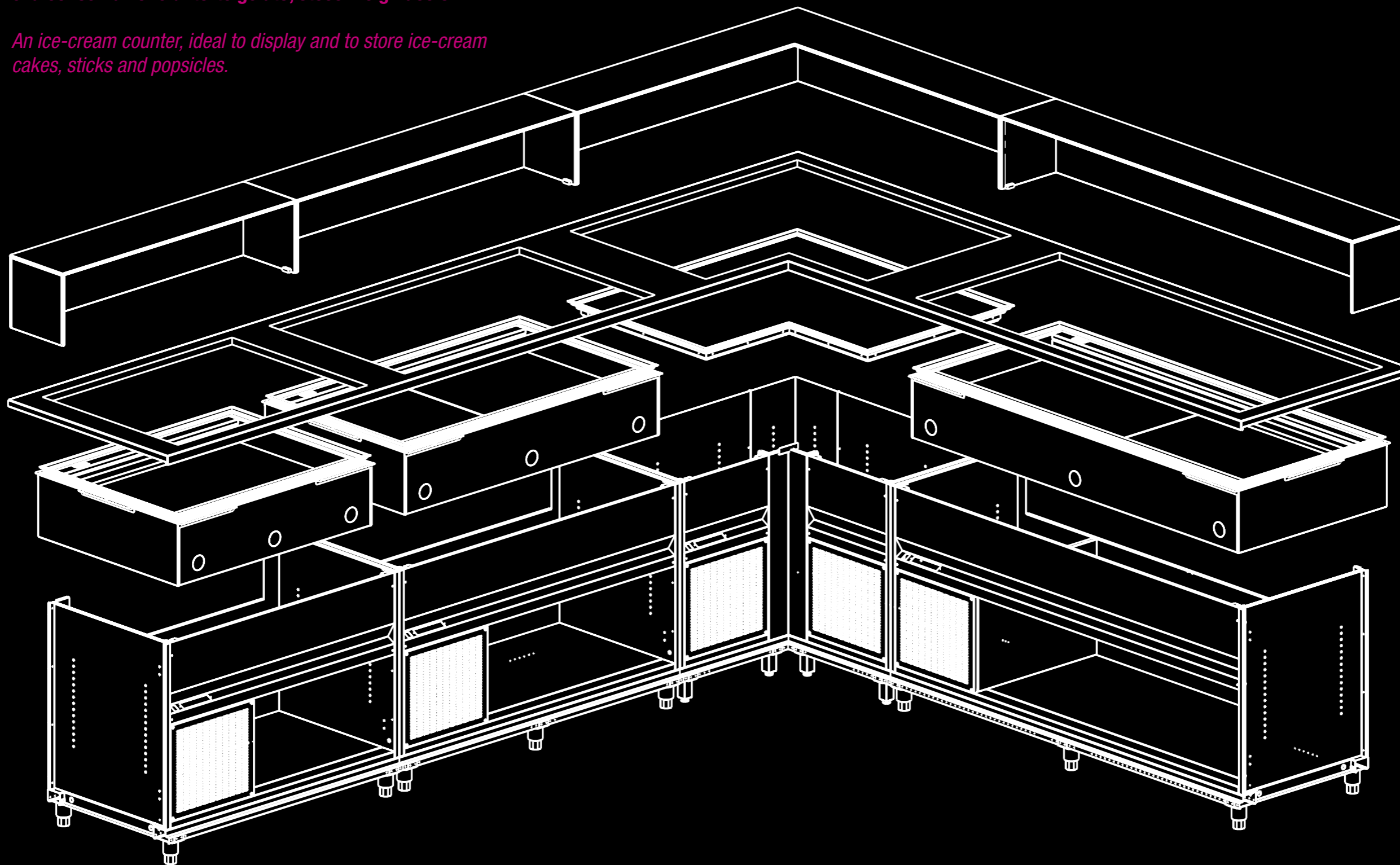

# 03 LE CORNICI THE FRAMES

DROP IN

DROP IN



**SOTTOTOP**  
Le vasche vengono fornite con staffe di sostegno

*UNDERMOUNT*  
The drop-in wells are supplied with fixing clamps



**SMALL**  
Elegante e minimale rifinisce il bordo del top

*SMALL*  
Elegant and minimal, it finishes the working top edge



**STEP**  
Elegante e minimale sul piano, la speciale conformazione della cornice permette l'appoggio dei moduli Gastronorm e l'inserimento di pianetti di appoggio o di copertura

*STEP*  
elegant and minimal on the working top, the special structure of the frame allows to rest Gastronorm modules and to insert top and closing surfaces.



**DROP**  
La cornice drop viene fornita già collegata per l'inserimento della vasca dall'alto. La sua conformazione permette l'appoggio dei moduli GN e l'inserimento di pianetti di appoggio o di copertura

*DROP*  
It's supplied already connected to insert the tub from the top. Its structure allows to rest Gastronorm modules and to insert top and closing surfaces.

# 03 ACCESSORI PER CORNICI ACCESSORIES FOR FRAMES

DROP IN

DROP IN



## STEP

LA SPECIALE CONFORMAZIONE DELLA CORNICE STEP E DROP PERMETTE L'APPOGGIO DEI MODULI GASTRONORM E L'INSERIMENTO DI PIANETTI DI APPOGGIO O DI COPERTURA.

## DROP

THE SPECIAL STRUCTURE OF STEP AND DROP FRAMES ALLOWS TO REST GASTRONORM MODULES AND TO INSERT TOP AND CLOSING SURFACES.



**Coperchio Inox**  
Stainless Steel Cover



**Tagliere in materiale sintetico**  
Cutting board in synthetic material

# 03 **UNA VASCA, MILLE FUNZIONI** *ONE DROP-IN MODEL, THOUSAND FUNCTIONS*

DUAL

**Dual drop-in permette di creare una composizione di banchi con tutte le funzioni perfettamente allineate: gelateria, pasticceria, pralineria e gastronomia.**

*Dual drop-in allows to set up a full counters composition with all the different functions perfectly aligned: gelato, pastry, chocolate and gastronomy*

DROP IN

DUAL



03

**Freddo Ventilato e doppia funzione alta visibilità  
mantenendo una funzionalità ottimale.**

*Cold ventilated and dual mode function high visibility  
keeping the best functionality.*

DROP IN

DUAL

**DUAL è l'ideale per progettare banchi  
espositivi moderni di grande visibilità  
ed esporre un'infinità di prodotti alla  
temperatura ideale.**

*DUAL is ideal to design modern display counters  
with total visibility, and to exhibit lots of products  
at the ideal temperature.*

03 **DA PASTICCERIA A SALADETTE:**  
**UN UTILIZZO DIVERSO NELL'ARCO DELLA GIORNATA**  
*FROM PASTRY TO SALADETTE: A DIFFERENT USE OVER THE DAY*

DUAL

DROP IN

DUAL



**La speciale  
 conformazione della  
 cornice permette un  
 utilizzo differente nel  
 corso della giornata.**

*The special frame's  
 structure allows to use  
 the DROP-IN in different  
 ways during the day.*



**Possibilità di  
 aggiungere cella  
 refrigerata h. 500.**

*Possibility to add  
 the refrigerated  
 undercounter h. 500.*

**PIANI ESPOSITIVI IN ACCIAIO INOX (FORNITURA STANDARD)**  
*DISPLAY SURFACES IN STAINLESS STEEL (SUPPLIED AS STANDARD)*

N. 3 L1084

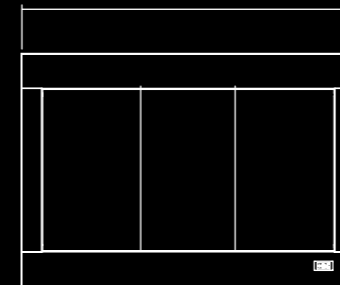

N. 4 L1411

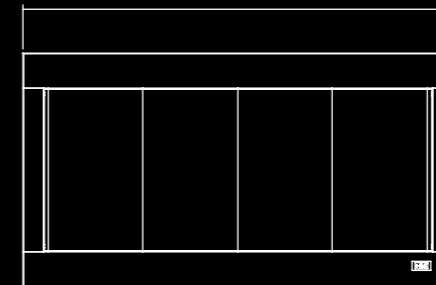

N. 5 L1738

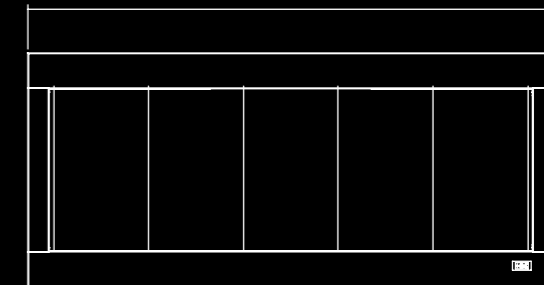

**ESEMPI DI ALLESTIMENTO CON VASCHE GASTRONORM CON COPERCHIO (OPTIONAL)**  
*EXAMPLES OF CONFIGURATIONS WITH GN GASTRONORM POTS WITH LID (OPTIONAL)*

N. 3 x 1/1 GN L1084

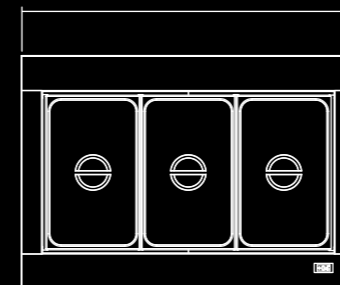

N. 4 x 1/1 GN L1411

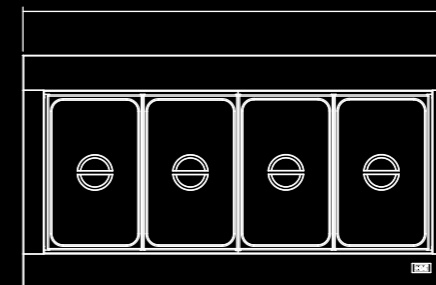

N. 5 x 1/1 GN

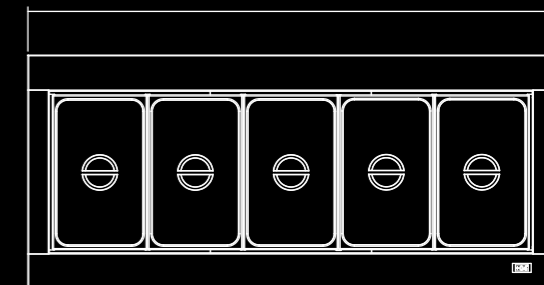

# 03 UNA VASCA MILLE FUNZIONI ONE TUB ONE THOUSAND FUNCTIONS

DUAL VANTAGGI / DUAL ADVANTAGES

DROP IN

DUAL



OPTIONAL: APERTURA  
TRAMITE PISTONI  
OPTIONAL: OPENING  
BY PISTONS

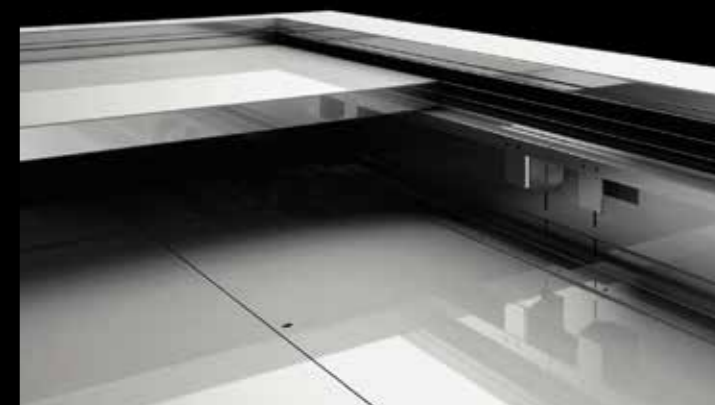
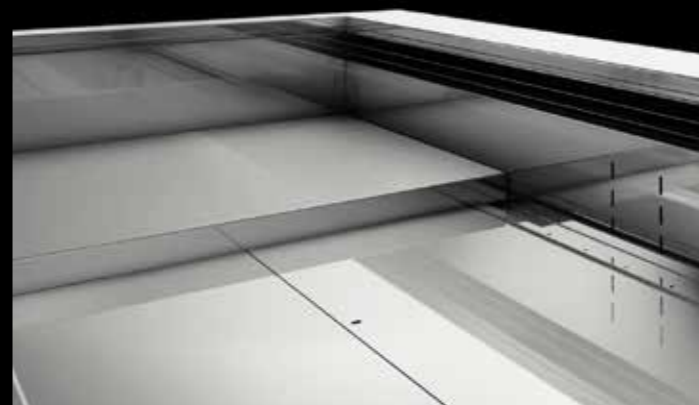
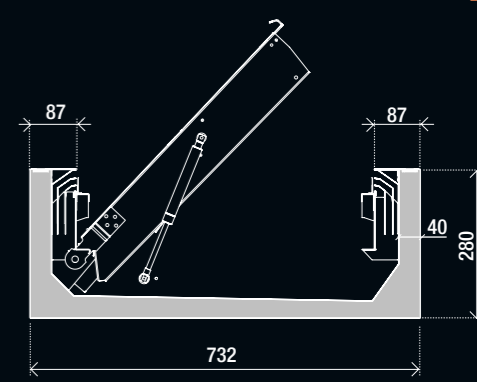

**Facilità di pulizia: ispezione evaporatore apertura a libretto**  
*Easy cleaning: evaporator inspection by folding the cover top*

**Piano espositivo regolabile in 4 posizioni.**  
*Adjustable display surface in 4 positions.*

# 03 DUAL BT PORTA STECCHI DUAL FREEZER STICKS HOLDER

**FREEZER**

**DROP IN**

**DUAL BT  
FREEZER**



L = 1088 N° 2

L = 1580 N° 3

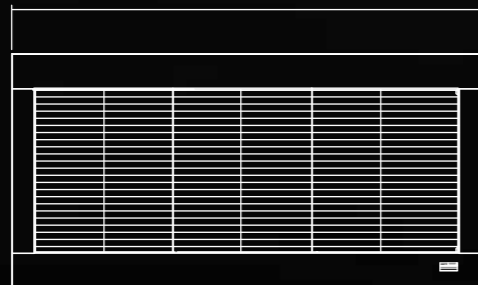

**OPTIONAL:**  
COPPIA DI VASSOI PORTASTECCHI  
IN ACCIAIO INOX  
*OPTIONAL:*  
COUPLE OF STICK HOLDER TRAYS IN  
STAINLESS STEEL

# 03 VASCHE GELATO, PORTASTECCHI E TORTE GELATO TRAYS, STICKS HOLDERS AND CAKES

DROP IN

DROP IN

DUAL BT  
FREEZER



Vasca DUAL completa di kit portastecchi e teca in vetro con illuminazione led e scorrevoli posteriori.



DUAL DROP-IN complete with stickholder kit, and glass canopy with led lighting and rear sliding doors.

I pianetti sono regolabili e indipendenti. Permettono un'esposizione del prodotto a diverse altezze.

The shelves are adjustable and independent. They allow to display the product at different heights.

Possibilità tramite gli appositi accessori di esporre nella stessa vasca torte, gelato monoporzioni, ghiaccioli e stecchi.

Thanks to the specific accessories, you can display in the same DROP-IN ice-cream cakes, single-portion cakes, sticks and popsicles.



# 03 DUAL DROP-IN GELATERIA

THE COUNTER TURNS INTO AN ICE-CREAM UNIT

DUAL BT / FREEZER

Possibilità di inserire vaschette in acciaio inox di mm. 265x162 o 530x165 mm.  
 Possibility to equip the counter with stainless steel trays 265x162mm or 530x165 mm.

DROP IN

DUAL BT  
FREEZER



L = 1088 N° 6+6 x 1/4 GN



L = 1580 N° 9+9 x 1/4 GN



OPTIONAL:  
**VASCHEE GN PER GELATERIA**  
 OPTIONAL:  
 GN POTS FOR ICE CREAM

1/4 GN 265X162X H 100 MM  
 2/4 GN 530X162X H 100 MM



03 **SUPERFICI ESPOSITIVE SENZA INTERRUZIONI**  
*DISPLAY SURFACES WITHOUT INTERRUPTION*

DROP IN



NEA

**Semplicità di manutenzione e pulizia:**  
Grazie a pistoni a gas è possibile sollevare il piano espositivo e il sottostante evaporatore

*Easy of maintenance and cleaning:*  
Thanks to gas pistons the display deck and the evaporator underneath can be lifted up

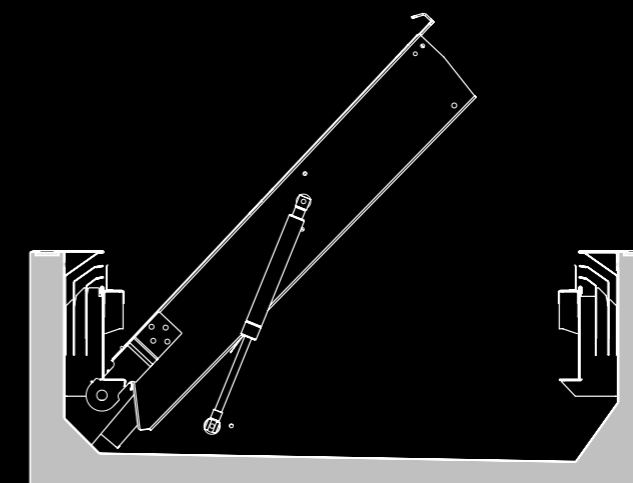

**OPTIONAL: APERTURA  
TRAMITE PISTONI**  
*OPTIONAL: OPENING  
BY PISTONS*



**Ottimizzazione  
degli spazi:**  
l'altezza della vasca  
permette l'inserimento  
della cella H. 500 di riserva.

*Space optimization:*  
the height of the DROP-IN  
allows to insert  
the refrigerated  
undercounter h. 500

# 03 CONTINUITÀ ESTETICA ED ESPOSITIVA AESTHETIC UNIFORMITY AND CONTINUOUS DISPLAY SURFACE

NEA

La perfetta canalizzazione tra più moduli crea un'unica superficie espositiva senza interruzioni.

*Perfectly canalized modules create a single continuous display surface.*



Le nostre vasche sono studiate per adattarsi ad ogni tipo di materiale, perfette per qualsiasi tipo di rivestimento, per ottenere sempre il risultato estetico desiderato.

*Our DROP-IN are designed to fit any type of material, perfect for any type of finishing to consistently achieve the desired aesthetic result.*

**TECNOLOGIA E MODULARITÀ PER IMMAGINARE  
E REALIZZARE QUALSIASI TIPOLOGIA DI LOCALE**

**03** *TECHNOLOGY AND MODULARITY TO IMAGINE  
AND REALIZE ANY KIND OF PLACE*

P60 - P80

DROP IN

P60 - P80

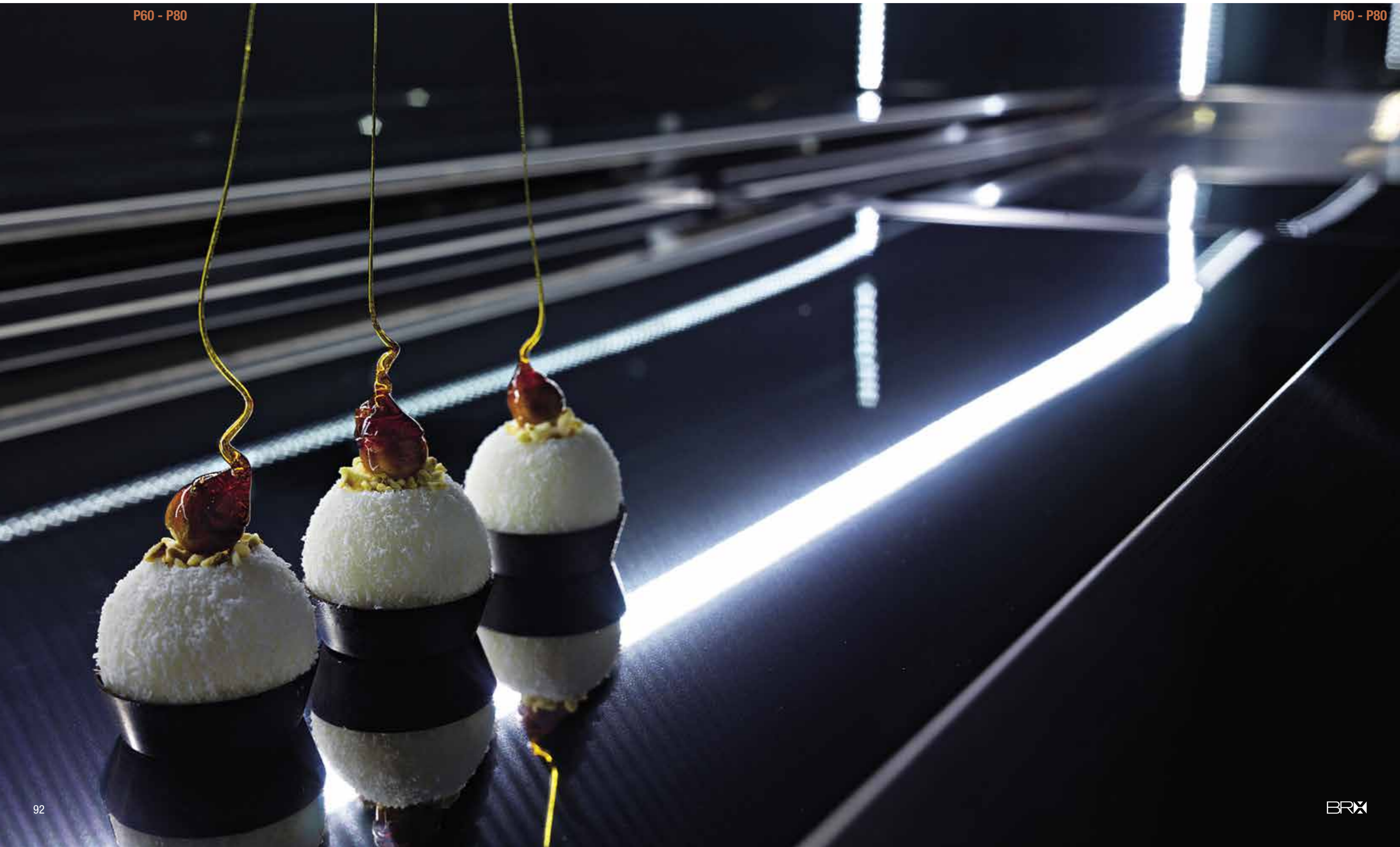

03



**P60 VASCA STATICA CON VASCA GN2/1 FORATA PER GHIACCIO, PER BAR E RISTORAZIONE VELOCE.**

*P60 STATIC DROP-IN WITH PERFORATED GN TRAY 2/1 FOR ICE, FOR BAR AND FAST FOOD.*

DROP IN

P60

**Grazie alla possibilità di aggiungere vaschette gastronorm, la vasca P60 può essere utilizzata per prodotti diversi anche nell'arco della stessa giornata.**

*Thanks to the possibility of adding gastronorm trays, the well p60 can be used for different products even over the same day.*



**P60 VASCA STATICA GUARNIZIONI PER GELATERIA E YOGURTERIA**

*P60 STATIC TOPPING DROP-IN FOR ICE CREAM AND YOGURT SHOP*



**P60 VASCA STATICA SALADETTE PER BAR E RISTORAZIONE VELOCE**

*P60 STATIC SALADETTE FOR BAR AND FAST FOOD*

03 **PER OGNI MOMENTO DELLA GIORNATA**  
*FOR EVERY MOMENT OF THE DAY*

P60 - P80

DROP IN

P60 - P80



**FREDDO VENTILATO, ESPOSIZIONE IDEALE PER UNA TEMPERATURA IDEALE. LA VASCA VENTILATA CONSERVA IL FRESCO COSTANTE ED EQUILIBRATO. IL PIANO RIBASSATO DI POCHI CENTIMETRI OFFRE UNA MIGLIORE VISIBILITÀ.**

*COLD VENTILATED, IDEAL DISPLAY FOR AN IDEAL TEMPERATURE. THE VENTILATED TUB KEEPS A CONSTANT AND BALANCED COOL. THE TOP SURFACE, A FEW CENTIMETERS LOWERED, OFFERS A BETTER VISIBILITY.*

03 **TECNOLOGIA MODULARE PER REALIZZARE QUALSIASI FORMA**  
*TECHNOLOGY MODULARITY TO REALIZE ANY SHAPE*

P60 - P80



**P60-P80 VASCA VENTILATA.**  
*P60-P80 VENTILATED DROP-IN.*

DROP IN

P60 - P80



**P60-P80 ANGOLO VASCA  
STATICA A CONTATTO O CALDO  
SECCO.**

*P60-P80 DROP-IN CORNER  
STATIC CONTACT COLD  
OR DRY-HEAT.*

**P60-P80 VASCA CALDO SECCO  
IN VETRO PIROLITICO NERO  
PER SALTARE IL PRODOTTO.**

*P60-P80 DRY-HEAT DROP-IN  
BLACK GLASS TO ENHANCE  
THE PRODUCT.*



**P60 VASCA BT PER L'ESPOSIZIONE E LA CONSERVAZIONE  
DI MONOPORZIONI, STECCHI E GHIACCIOLI**  
*P60 DROP-IN FREEZER VERSION TO SHOWCASE  
AND STORE GELATO CAKES (CONTROLLARE MONOPORZIONE  
IN INGLESE), STICKS AND POPSICLES*

03

P60 BT / FREEZER

DROP IN

P60 BT /  
FREEZER



03 **IDEALE DA INTEGRARE AL BANCO BAR**  
*IDEAL TO INTEGRATE TO THE BAR COUNTER*

**P60 COCKTAIL**



**P60 COCKTAIL TUTTO IL NECESSARIO PER LA PREPARAZIONE DEL COCKTAIL IN UNO SPAZIO PICCOLO E COMPLETO.**

*P60 COCKTAIL, EVERYTHING YOU NEED TO PREPARE COCKTAILS, IN A SMALL AND COMPLETE SPACE.*

**VASCA COCKTAIL:** vasca coibentata per mantenimento ghiaccio, vaschette GN 1/9 per fruttini e guarnizioni. Disponibile con e senza lavello.

*COCKTAIL STATION:* insulated tub for ice conservation, GN trays 1/9 for sauces, cream and toppings. Available with or without sink.



**DROP IN**

**P60  
COCKTAIL**

# 03 VASCHE FRUTTINI CALDE, FREDDI E NEUTRE TOPPING TUBS HOT, COLD AND NEUTRAL

FRUTTINI / TOPPINGS

DROP IN

FRUTTINI /  
TOPPINGS

GAMMA E FLESSIBILITÀ PER  
CREARE ANGOLI GUARNIZIONI  
IN QUALSIASI PROGETTO

RANGE AND FLEXIBILITY TO  
CREATE TOPPING STATIONS IN  
ANY PROJECT.

# 03 VASCHE FRUTTINI CALDE, FREDDE E NEUTRE TOPPING TUBS HOT, COLD AND NEUTRAL

FRUTTINI / TOPPINGS

Granelle, frutta fresca, cioccolato e crema calda... Ogni guarnizione ha la sua vasca  
Grains, fresh fruits, chocolate and hot cream...  
Each topping has its own well

NEUTRA  
NEUTRAL

REFRIGERATA  
REFRIGERATED

CALDA  
HOT



Prelibatezze  
calde o fredde:  
offri sempre  
qualcosa di  
unico, preparato  
e conservato al  
meglio.

Hot or cold  
deliciousness:  
offer something  
unique,  
prepared and  
maintained  
at its best.



**BRX**  
**SPECIALISTI IN POZZETTI GELATO**  
**E NON SOLO**

***BRX***  
***POZZETTI GELATO SPECIALISTS***  
***AND MUCH MORE***

**WWW.BRXITALIA.COM +39.0721.499611**

**BRX**

**POZZETTI GELATO & BAR TECHNOLOGY**



BRX

[WWW.BRXITALIA.COM](http://WWW.BRXITALIA.COM) +39.0721.499611