



# ICE VISION ION

GIOIA



SOLUZIONI D'ARREDO PER FOOD & BEVERAGE

Il freddo e' il nostro habitat

# GIOIA



# G



Gelato

# i



Pasticceria  
Pastry  
Konditorei  
Pâtisserie

# O



Pralineria  
Praline  
Pralinen  
Pralinerie

# i



Caldo a secco  
Dry heat  
Trockene Wärme  
Chaud à sec

# a



Bagno maria  
Bain marie  
Wasserbad  
Bain-marie

## IT

Modello di vetrina dalla vasta gamma di servizi: dal gelato alla pasticceria, pralineria e gastronomia. Il design della GIOIA rappresenta il carattere giovane e dinamico di Itai Proget.

Scocca monoblocco con isolamento in poliuretano spessore mm 60, vasca in acciaio inox AISI 304.

Illuminazione a LED.

Alzata vetri riscaldati anticondensa, apertura del vetro frontale a compasso, chiusura lato servizio con tendina auto avvolgente o scorrevoli in plexiglass.

Refrigerazione ventilata con doppio evaporatore.

Doppio compressore ermetico (nei modelli 18 e 24) per ottime prestazioni frigo, con basso livello di rumorosità. Optional compressore 400/3.

Unità condensatrice estraibile per una manutenzione semplice e veloce.

Sbrinamento automatico ultrarapido, ad inversione di ciclo.

Quadro comandi elettronico per la regolazione della temperatura.

classe climatica 7 (35°/ 75% UR).

## EN

Display case model offering a wide range of services: from ice-cream to pastries, candies to delicatessens. GIOIA design represents the young, dynamic character of Itai Proget.

One-piece shell with 60 mm-thick polyurethane insulation, AISI 304 stainless steel tank.

LED lighting.

Anti-condensation heated glass superstructure, vent-opening front glass, service side closure with wraparound curtain or sliding Plexiglass doors.

Ventilated refrigeration with double evaporators.

Double hermetic compressor (in models 18 and 24) for optimal refrigeration performance with low noise level. Optional compressor 400/3.

Removable condensing unit for easier, faster maintenance.

Automatic ultra-fast reverse cycle defrost.

Electronic control panel for temperature adjustment.

Climate class 7 (35°/ 75% UR).

## DE

Die vielseitige Vitrine mit verschiedenen Einsatzmöglichkeiten: geeignet für Eisdiele, Konditorei, Konfiserie und Gastronomie. Das Design von GIOIA verkörpert den jungen und dynamischen Geist von Itai Proget.

Monoblock-Gehäuse mit 60 mm dicker Polyurethan-Hartschaumisolierung, Edelstahlwanne AISI 304.

LED-Beleuchtung.

Beheizter Glasaufsatz mit Wärmedämmverglasung, Frontscheibe mit Klappöffnung, Schließung der Bedienerseite mit Thermorollo oder Plexiglas-Schiebescheibe.

Umluftkühlung mit zwei Verdampfern.

Doppelter hermetischer Kompressor (für Modelle 18 und 24) für erstklassige Kühlleistung, extrem geräuscharm. Optional erhältlicher Kompressor 400/3.

Entnehmbares Verflüssigeraggregat für einfache und rasche Wartung.

Ultraschnelle automatische Abtauung durch Zyklusinversion.

Elektronisches Schaltpult zum Einstellen der Temperatur.

Klimaklasse 7 (35°/ 75% UR).

## FR

Modèle de vitrine permettant une vaste gamme de services : de la glace à la pâtisserie, des chocolats à la gastronomie. Le design de GIOIA représente le caractère jeune et dynamique d'Itai Proget.

Châssis monobloc avec isolation en polyuréthane épaisseur 60 mm, cuve en acier inox AISI 304.

Éclairage à LED.

Montant vitres réchauffées anti-condensation, ouverture de la vitre frontale par compas, fermeture côté service avec rideau à enroulement automatique ou coulissant en plexiglas.

Réfrigération ventilée avec double évaporateur.

Double compresseur hermétique (dans les modèles 18 et 24) pour des performances de réfrigération optimales, avec niveau de bruit bas.

Compresseur 400/3 optionnel.

Unité de condensation amovible pour un entretien simple et rapide.

Dégivrage automatique ultra rapide, à cycle inversé.

Tableau de commandes électronique pour le réglage de la température.

Classe climatique 7 (35°/ 75% UR).

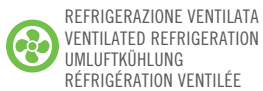

REFRIGERAZIONE VENTILATA  
VENTILATED REFRIGERATION  
UMLÜFTKÜHLUNG  
RÉFRIGÉRATION VENTILÉE



## DATI TECNICI / TECHNICAL DATA / TECHNISCHE DATEN / DONNEES TECHNIQUES

| MOD.                   |     |     |            |            |     |     |            |            | <br>[°C]  | POTENZA COMPRESSORE / POWER COMPRESSOR<br>PUISSANCE COMPRESSEUR / LEISTUNG VERDICHTER |                                      |  |   |                                      |  | N. Classe climatica<br>No. Climate class<br>Klimaklasse N°<br>Classe climatique N°<br>[C°/%UR] |
|------------------------|-----|-----|------------|------------|-----|-----|------------|------------|-----------|---|--------------------------------------|--|---|--------------------------------------|--|--|
|                        | L   | P   | H          | kg         | L   | P   | H          | kg         |           | Monofase / Single-phase / Einphasig / Monophasé                                       |                                      | Trifase / Three-phase / Dreiphasig / Triphasé        |   |                                      |  |  |
|                        |     |     |            |            |     |     |            |            |           | Tensione Supply Spannung Tension [V/Hz]   | Regime Output Verhältnis Régime [Kw] | Sbrinamento In Defrost Zeitgesteuerte Dégivrage [Kw] | Tensione Supply Spannung Tension [V/Hz] | Regime Output Verhältnis Régime [Kw] | Sbrinamento In Defrost Zeitgesteuerte Dégivrage [Kw] |  |
| <b>GIOIA GELATO 12</b> | 112 | 106 | 122<br>138 | 235<br>245 | 127 | 121 | 156<br>156 | 270<br>280 | -16 / -18 | 230/1/50  | 1.51                                 | 2.15   | 400/3/50                                | 1.3                                  | 2.52   | 7 (35/75)  |
| <b>GIOIA GELATO 18</b> | 162 | 106 | 122<br>138 | 325<br>335 | 178 | 121 | 156<br>156 | 357<br>367 | -16 / -18 | 230/1/50  | 2.08                                 | 3.53   | 400/3/50                                | 1.97                                 | 3.87   | 7 (35/75)  |
| <b>GIOIA GELATO 24</b> | 214 | 106 | 122<br>138 | 390<br>400 | 228 | 121 | 156<br>156 | 470<br>480 | -16 / -18 | 230/1/50  | 2.5                                  | 3.8  | 400/3/50                                | 2.8                                  | 5.1  | 7 (35/75)  |

# H122

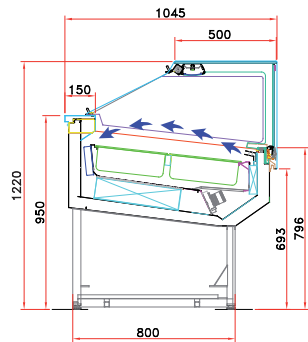

Base / Basic  
Basis / Base

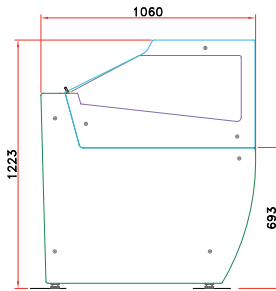

Pannellata / With panels  
Mit Paneelen / Avec des panneaux

# H138

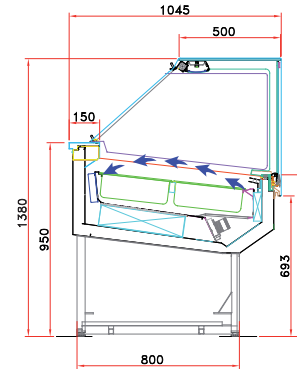

Base / Basic  
Basis / Base

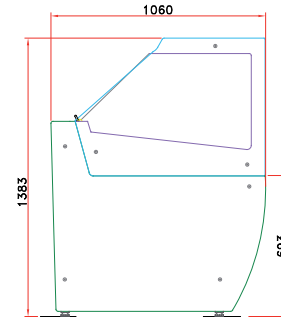

Pannellata / With panels  
Mit Paneelen / Avec des panneaux

## GIOIA GELATO 12

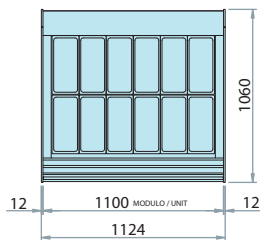

## GIOIA GELATO 18

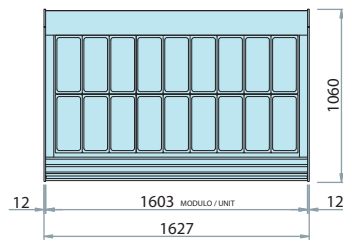

## GIOIA GELATO 24

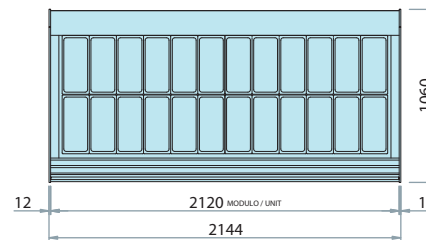

**STANDARD** L x P x H  
360 x 165 x 120 [5Lt.]

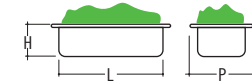

**LARGE** L x P x H  
360 x 250 x 80 [7Lt.]  
360 x 250 x 120 [10Lt.]

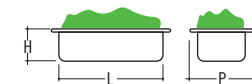

### DI SERIE / STANDARD / DI SERIE / SÉRIE

Sbrinamento auto. elettr. / Automatic electric defrost / Zeitgesteuerte abtauautomatik / Dégivrage automatique  
Unità di controllo elettr. / Electronic control unit / Elektronische steuereinheit / Unité de contrôle électronique  
Fluido refrigerante R404A / R404A refrigerant gas / Kühlgas R404A / Gaz réfrigérant R404A

### COLORI / COLOURS / FARBEN / COULEURS



Le vetrine possono essere personalizzate nei colori RAL in commercio.  
The showcase can be customized in colors according to available RAL.  
Die Vitrinen können in handelsüblichen RAL-Farben gestaltet werden.  
Les vitrines peuvent être personnalisées selon les coloris RAL dans le commerce.

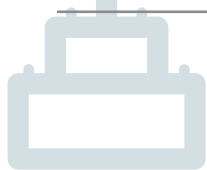

REFRIGERAZIONE CON FLUSSO SOFT  
REFRIGERATED WITH SOFT FLOW SYSTEM  
KÜHLUNG MIT SOFT-FLOW-SYSTEM  
RÉFRIGÉRATION AVEC FLUX SOFT



REFRIGERAZIONE VENTILATA FULL  
FULL VENTILATED REFRIGERATION  
VOLLSTÄNDIGE UMLUFTKÜHLUNG  
RÉFRIGÉRATION VENTILÉE FULL

## DATI TECNICI / TECHNICAL DATA / TECHNISCHE DATEN / DONNEES TECHNIQUES



| MOD.                  |     |     |            |            |     |     |            |            |         | Resa frigo<br>Refrigeration power<br>Kühlschrank Ausbeute<br>Rendement frigo | Tensione<br>Supply<br>Spannung<br>Tension | Potenza assorbita<br>Electrical power output<br>Absorbierte leistung<br>Puissance absorbée | N. Classe climatica<br>No. Climate class<br>Klimaklasse N°<br>Classe climatique N° |
|-----------------------|-----|-----|------------|------------|-----|-----|------------|------------|---------|--|---|--|--|
|                       | L   | P   | H          | kg         | L   | P   | H          | kg         |         |  |   |  |  |
| <b>GIOIA PAST 110</b> | 112 | 106 | 122<br>138 | 214<br>224 | 127 | 121 | 156<br>156 | 254<br>260 | +2 / +4 | -  | 230/1/50                                  | 0.66<br>0.66 - 1.18  | 4+(32/60)  |
| <b>GIOIA PAST 160</b> | 162 | 106 | 122<br>138 | 285<br>302 | 178 | 121 | 156<br>156 | 330<br>342 | +2 / +4 | -  | 230/1/50                                  | 0.85<br>0.85 - 1.32  | 4+(32/60)  |
| <b>GIOIA PAST 200</b> | 214 | 106 | 122<br>138 | 337<br>353 | 228 | 121 | 156<br>156 | 396<br>400 | +2 / +4 | -  | 230/1/50                                  | 1.1<br>1.1 - 1.48  | 4+(32/60)  |

# H122

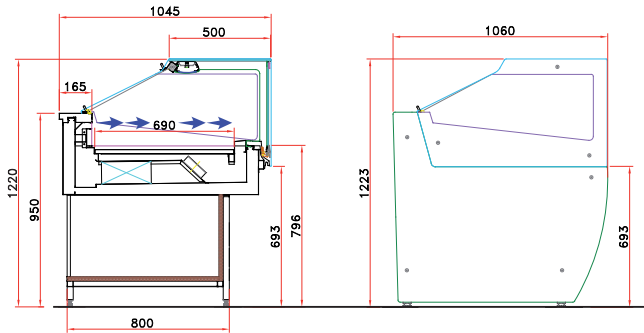

Base / Basic  
Basis / Base

Pannellata / With panels  
Mit Paneelen / Avec des panneaux

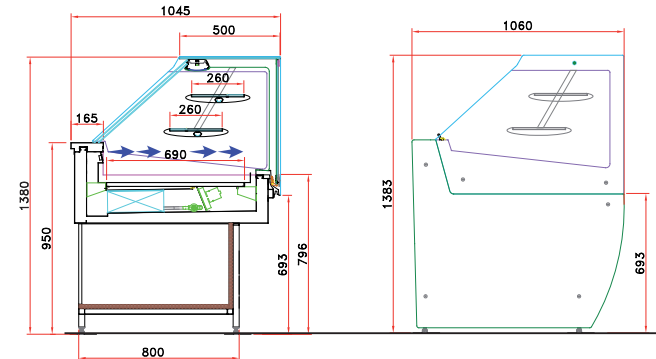

Base / Basic  
Basis / Base

Pannellata / With panels  
Mit Paneelen / Avec des panneaux

## GIOIA PAST 110

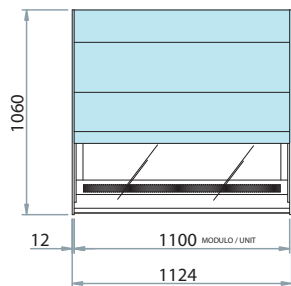

## GIOIA PAST 160

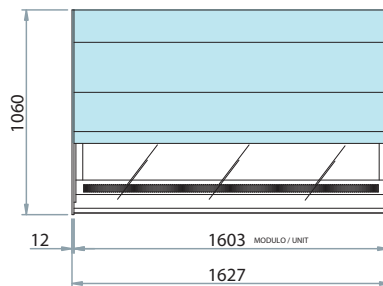

## GIOIA PAST 200

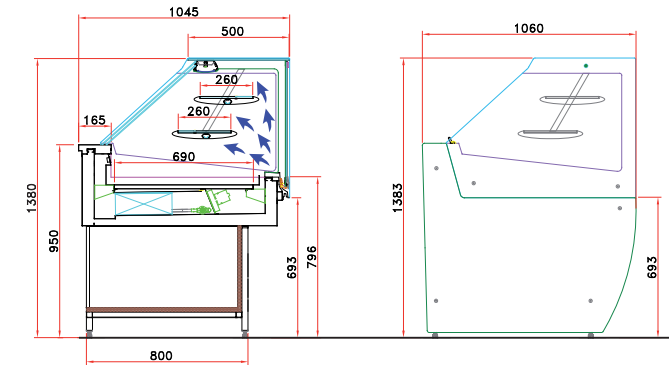
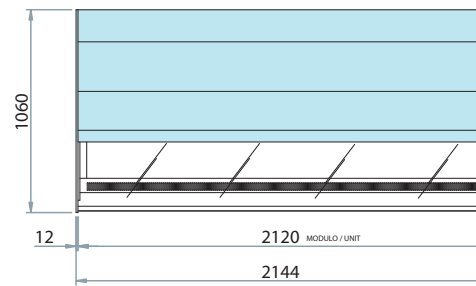

Base / Basic  
Basis / Base

Pannellata / With panels  
Mit Paneelen / Avec des panneaux



Fornita con scorrevoli in plexiglass  
Provided with sliding plexiglass  
Mit Schiebern aus Plexiglas  
Fournie avec portes coulissantes en plexiglas

**NO** TENDINA / CURTAIN  
VORHANG / RIDEAU

## DI SERIE / STANDARD / DI SERIE / SÉRIE

Sbrinamento auto. elettr. / Automatic electric defrost / Zeitgesteuerte abtauautomatik / Dégivrage automatique  
Unità di controllo elettr. / Electronic control unit / Elektronische steuereinheit / Unité de contrôle électronique  
Fluido refrigerante R404A / R404A refrigerant gas / Kühlgas R404A / Gaz réfrigérant R404A

## COLORI / COLOURS / FARBEN / COULEURS



Le vetrine possono essere personalizzate nei colori RAL in commercio.  
The showcase can be customized in colors according to available RAL.  
Die Vitrinen können in handelsüblichen RAL-Farben gestaltet werden.  
Les vitrines peuvent être personnalisées selon les coloris RAL dans le commerce.

# GIOIA Pralineria / Praline / Pralinen / Pralinerie



REFRIGERAZIONE CON FLUSSO SOFT  
REFRIGERATED WITH SOFT FLOW SYSTEM  
KÜHLUNG MIT SOFT-FLOW-SYSTEM  
RÉFRIGÉRATION AVEC FLUX SOFT



## DATI TECNICI / TECHNICAL DATA / TECHNISCHE DATEN / DONNEES TECHNIQUES

| MOD.                |     |     |            |            |     |     |            |            | <br>°C       | Resa frigo<br>Refrigeration power<br>Kühlschrank Ausbeute<br>Rendement frigo<br>[Kw] | Tensione<br>Supply<br>Spannung<br>Tension<br>[V/Hz] | Potenza assorbita<br>Electrical power output<br>Absorbierte leistung<br>Puissance absorbée<br>[Kw] | N. Classe climatica<br>No. Climate class<br>Klimaklasse N°<br>Classe climatique N°<br>[C°/%UR] |
|---------------------|-----|-----|------------|------------|-----|-----|------------|------------|--------------|--|---|--|--|
|                     | L   | P   | H          | kg         | L   | P   | H          | kg         |              |  |   |  |  |
| <b>GIOIA PR 110</b> | 112 | 106 | 122<br>138 | 214<br>224 | 127 | 121 | 156<br>156 | 265<br>275 | +15<br>UR%60 | 0.36   | 230/50+   | 0.66   | 4+(32/60)  |
| <b>GIOIA PR 160</b> | 162 | 106 | 122<br>138 | 285<br>302 | 178 | 121 | 156<br>156 | 330<br>342 | +15<br>UR%60 | 0.51   | 230/50+   | 0.85   | 4+(32/60)  |
| <b>GIOIA PR 200</b> | 214 | 106 | 122<br>138 | 337<br>347 | 228 | 121 | 156<br>156 | 407<br>417 | +15<br>UR%60 | 0.71   | 230/50+   | 1.1  | 4+(32/60)  |

# H122

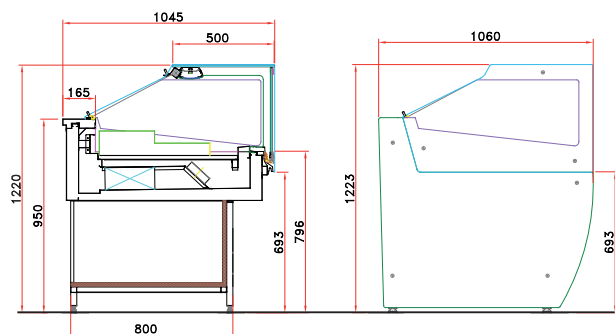

Base / Basic  
Basis / Base

Pannellata / With panels  
Mit Paneelen / Avec des panneaux

# H138

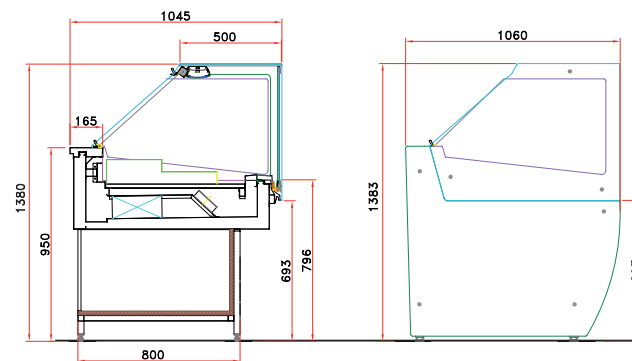

Base / Basic  
Basis / Base

Pannellata / With panels  
Mit Paneelen / Avec des panneaux

## GIOIA PR 110

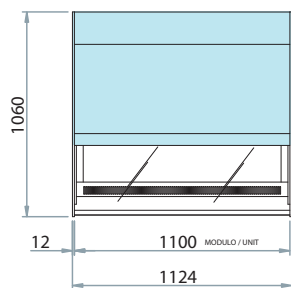

## GIOIA PR 160

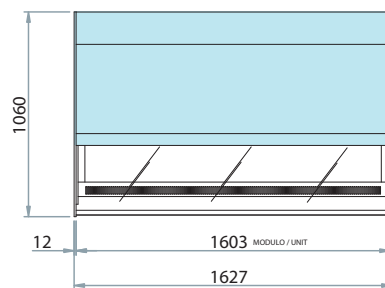

## GIOIA PR 200

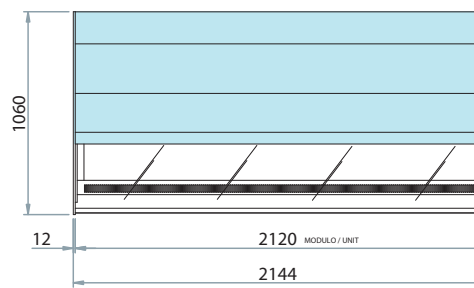

### DI SERIE / STANDARD / DI SERIE / SÉRIE

Sbrinamento auto. elettr. / Automatic electric defrost / Zeitgesteuerte abtauautomatik / Dégivrage automatique  
 Unita' di controllo elettr. / Electronic control unit / Elektronische steuereinheit / Unité de contrôle électronique  
 Fluido refrigerante R404A / R404A refrigerant gas / Kühlgas R404A / Gaz réfrigérant R404A

### COLORI / COLOURS / FARBEN / COULEURS



Le vetrine possono essere personalizzate nei colori RAL in commercio.  
 The showcase can be customized in colors according to available RAL.  
 Die Vitrinen können in handelsüblichen RAL-Farben gestaltet werden.  
 Les vitrines peuvent être personnalisées selon les coloris RAL dans le commerce.

# GIOIA

Caldo a secco / Dry heat / Trockene Wärme / Chaud à sec



## DATI TECNICI / TECHNICAL DATA / TECHNISCHE DATEN / DONNEES TECHNIQUES



| MOD.                |     |     |            |            |     |     |            |            | <br>°C    | Resa frigo<br>Refrigeration power<br>Kühlschrank Ausbeute<br>Rendement frigo<br>[Kw] | Tensione<br>Supply<br>Spannung<br>Tension<br>[V/Hz] | Potenza assorbita<br>Electrical power output<br>Absorbierte leistung<br>Puissance absorbée<br>[Kw] | N. Classe climatica<br>No. Climate class<br>N. Classe climatica<br>No. Climate class<br>[C°/%UR] |
|---------------------|-----|-----|------------|------------|-----|-----|------------|------------|-----------|--|---|--|--|
|                     | L   | P   | H          | kg         | L   | P   | H          | kg         |           |  |   |  |  |
| <b>GIOIA CS 110</b> | 112 | 106 | 122<br>138 | 188<br>224 | 127 | 121 | 156<br>156 | 238<br>248 | +40 / +60 | -  | 230/50+   | 0.6  | -  |
| <b>GIOIA CS 160</b> | 162 | 106 | 122<br>138 | 253<br>275 | 178 | 121 | 156<br>156 | 293<br>315 | +40 / +60 | -  | 230/50+   | 1.2  | -  |
| <b>GIOIA CS 200</b> | 214 | 106 | 122<br>138 | 305<br>320 | 228 | 121 | 156<br>156 | 395<br>405 | +40 / +60 | -  | 230/50+   | 1.8  | -  |

# H122

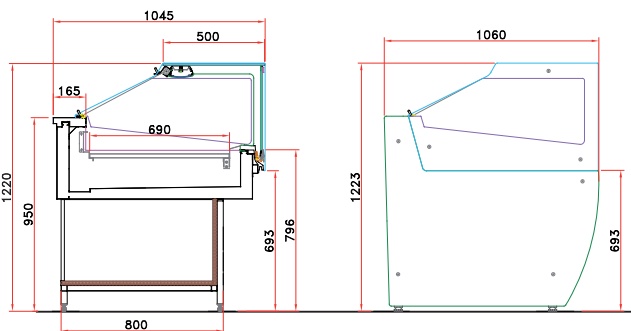

Base / Basic  
Basis / Base

Pannellata / With panels  
Mit Paneelen / Avec des panneaux

# H138

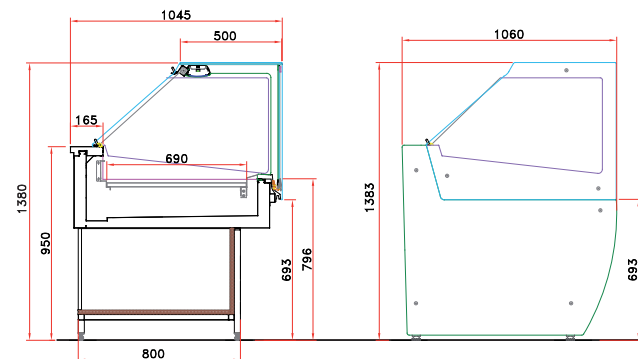

Base / Basic  
Basis / Base

Pannellata / With panels  
Mit Paneelen / Avec des panneaux

## GIOIA CS 110

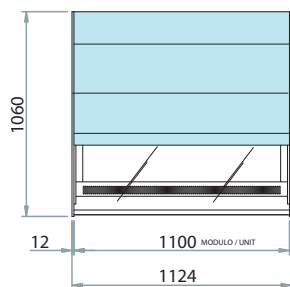

## GIOIA CS 160

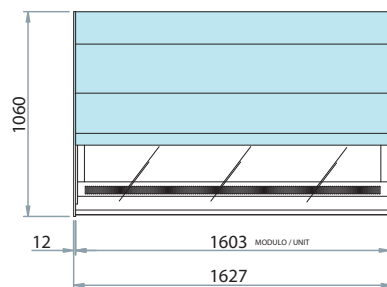

## GIOIA CS 200

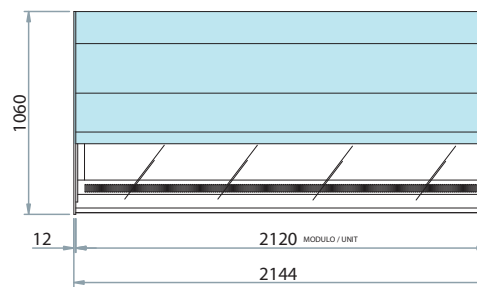

### DI SERIE / STANDARD / DI SERIE / SÉRIE

Unità di controllo elettr. / Electronic control unit / Elektronische steuereinheit / Unité de contrôle électronique

### COLORI / COLOURS / FARBEN / COULEURS



Le vetrine possono essere personalizzate nei colori RAL in commercio.  
The showcase can be customized in colors according to available RAL.  
Die Vitrinen können in handelsüblichen RAL-Farben gestaltet werden.  
Les vitrines peuvent être personnalisées selon les coloris RAL dans le commerce.



## DATI TECNICI / TECHNICAL DATA / TECHNISCHE DATEN / DONNEES TECHNIQUES



| MOD.                    |     |     |            |            |     |     |            |            | <br>[°C]  | Resa frigo<br>Refrigeration power<br>Kühlschrank Ausbeute<br>Rendement frigo<br>[Kw] | Tensione<br>Supply<br>Spannung<br>Tension<br>[V/Hz] | Potenza assorbita<br>Electrical power output<br>Absorbierte leistung<br>Puissance absorbée<br>[Kw] | N. Classe climatica<br>No. Climate class<br>N. Classe climatica<br>No. Climate class<br>[C°/%UR] |
|-------------------------|-----|-----|------------|------------|-----|-----|------------|------------|-----------|--|---|--|--|
|                         | L   | P   | H          | Person     | L   | P   | H          | Person     |           |  |   |  |  |
| <b>GIOIA<br/>BM 110</b> | 112 | 106 | 122<br>138 | 188<br>224 | 127 | 121 | 156<br>156 | 238<br>248 | +40 / +90 | -  | 230/50+   | 1.5  | -  |
| <b>GIOIA<br/>BM 160</b> | 162 | 106 | 122<br>138 | 253<br>280 | 178 | 121 | 156<br>156 | 318<br>320 | +40 / +90 | -  | 230/50+   | 2.4  | -  |
| <b>GIOIA<br/>BM 200</b> | 214 | 106 | 122<br>138 | 305<br>320 | 228 | 121 | 156<br>156 | 395<br>405 | +40 / +90 | -  | 230/50+   | 3  | -  |

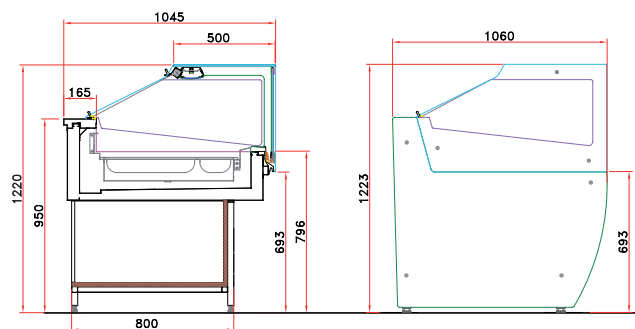

Base / Basic  
Basis / Base

Pannellata / With panels  
Mit Paneelen / Avec des panneaux

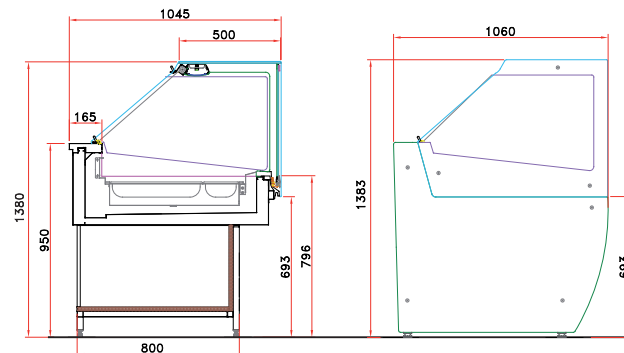

Base / Basic  
Basis / Base

Pannellata / With panels  
Mit Paneelen / Avec des panneaux

GIOIA BM 110

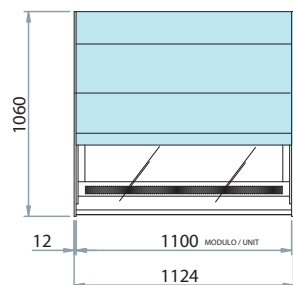

GIOIA BM 160

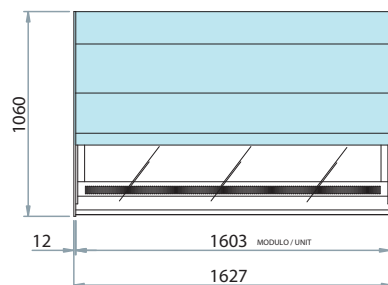

GIOIA BM 200

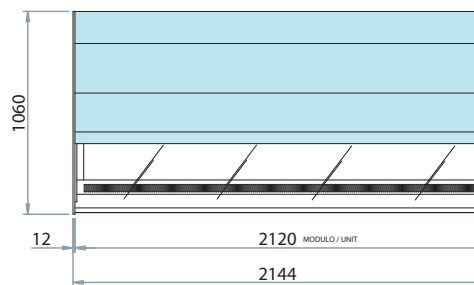

VASCETTE / CONTAINERS / SCHALEN / BARQUETTES

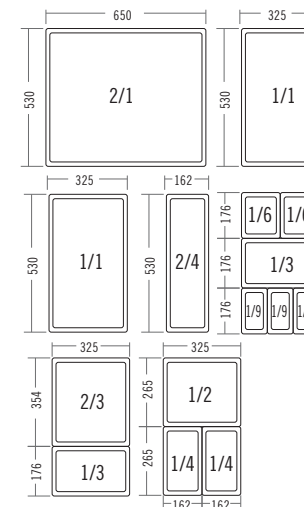

NOTE / NOTE / NOTES / NOTES

Vaschette e coperchi non compresi / Containers and lids not included  
Schalen und Deckel nicht inbegriffen / Les barquettes et les couvercles ne sont pas compris

DI SERIE / STANDARD / DI SERIE / SÉRIE

Unità di controllo elettr. / Electronic control unit / Elektronische steuereinheit / Unité de contrôle électronique

COLORI / COLOURS / FARBEN / COULEURS

Le vetrine possono essere personalizzate nei colori RAL in commercio.  
The showcase can be customized in colors according to available RAL.  
Die Vitrinen können in handelsüblichen RAL-Farben gestaltet werden.  
Les vitrines peuvent être personnalisées selon les coloris RAL dans le commerce.





Italian Gelato Concepts Pty Limited  
Unit 1, 37 Mortimer Road  
Acacia Ridge Qld 4110

Bris Office: +61 [0] 7 3162 7724  
Syd Office +61 [0] 2 8311 9701  
Email: [info@italiangelato.com.au](mailto:info@italiangelato.com.au)

[www.italiangelato.com.au](http://www.italiangelato.com.au)



SOLUZIONI D'ARREDO PER FOOD & BEVERAGE

AF DESIGN 0118 - ICEVISION