

NACHI

Standard specifications

SRA-01-FD11/FD18
SRA-01A-FD11/FD18
SRA-L-01-FD11/FD18
SRA-EL-01-FD11/FD18

19th edition

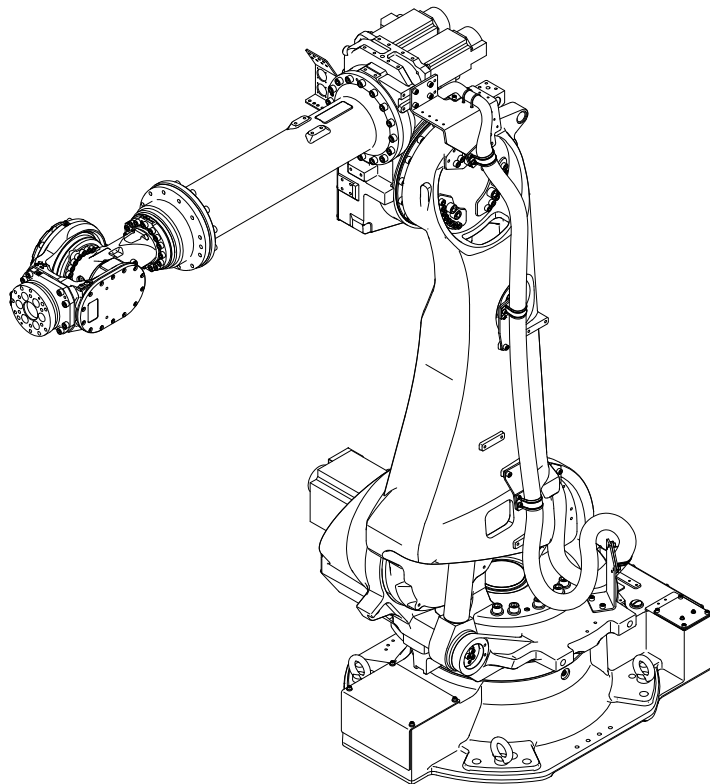

NACHI-FUJIKOSHI CORP.

2011, SSRAEN-041-019,001

Table of contents

1. Outline.....	1
2. Basic specifications.....	2
3. Robot dimensions and Motion range.....	5
4. Detail of load mounting face.....	12
5. Installation procedure.....	16
6. Allowable wrist load.....	20
7. Option specifications.....	33
8. Application wiring and piping diagram.....	35
9. Transport procedure.....	39
10. Delivery style (specification which contains a robot).....	41
11. Consuming power (Robot + Controller).....	41
12. Paint color.....	41
13. Warranty.....	41

1. Outline

NACHI ROBOT “SRA series” is optimal robot for spot welding, material handling and other applications, and provides dramatically improved productivity by its overwhelming speed and compact body.

This series contains not only the “Standard type” but also the “A-Trac4 type” which equips the best designed cable support system for spot welding, and furthermore contains the “Long arm type” which spreads its operating range.

Standard type

	Max. payload 100 kg	Max. payload 166 kg	Max. payload 210 kg	Max. payload 240 kg	Max. payload 250 kg
Floor mount	SRA100-01	SRA166-01	SRA210-01	SRA240-01	SRA250-01

A-Trac4 type

	Max. payload 100 kg	Max. payload 166 kg	Max. payload 210 kg
Floor mount	SRA100-01A	SRA166-01A	SRA210-01A

Long arm type

	Max. payload 120 kg	Max. payload 133 kg	Max. payload 166 kg
Extended arm length	450 mm	300 mm	300 mm
Floor mount	SRA120EL-01	SRA133L-01	SRA166L-01

A-trac4 for long arm type can be manufactured after order.

■ World class speed robot

- Cycle time reduced 30% (*1) from existing model by 3 improvements of light weight, high rigidity and quick motion control, resulting in high acceleration and minimum vibration.

■ Ease of use

- Operating range of robot is irrelevant to the payload mass. Axis 5 (wrist) operating range is maximum in its class. These features open the robot to more diverse applications, thus resulting in easier application design (*2).
- By installing the balance unit inside arm, swivel base becomes slim (floor mount type). Slim and compact design allows closer installation in less floor space.
- Sufficient application wires and tubes are installed inside arm in order to apply to bigger and high function tool.

■ Improved energy efficiency

- Power consumption reduced 15% from existing model by reducing the robot’s weight by 20% and using cutting edge motor drive controls.

■ “A-Trac4” that is the best design for spot welding

- Spot welding cables are installed around the fore arm (axis 3 arm). Because the cable behavior is stably connected with the robot’s motion, reliability of cables has substantially advanced.
- In case of off-line programming (*3), taught robot pose and cable arrangement needs to be modified because the cable behavior is difficult to simulate. But by utilizing “A-Trac4”, this work is unnecessary, thus the lead-time until startup of the production line can be reduced.

*1; Comparison of SRA166-01-FD and existing model ST166-AX, spot welding work with 27 spots on flat panel.

*2; “Application” is the purpose of robot’s usage. For example, spot welding and material handling.

*3; “Off-line programming” is teaching the robot program on desk, prior to installing the real robot. Computer (hardware) and special simulator (software) are necessary except robot.

2. Basic specifications

Standard type

Item		Specifications				
Robot type		SRA100-01	SRA166-01	SRA210-01	SRA240-01	SRA250-01
Structure		Articulated				
Degree of Freedom		6				
Drive system		AC servo motor				
Maximum Motion range	Axis 1	±3.14 rad (±180°)				
	Axis 2	-1.40 ~ +1.05 rad (-80 ~ +60°)				
	Axis 3	-2.56 ~ +2.62 rad (-146.5 ~ +150°)				-2.44 ~ +2.62rad (-140 ~ +150°)
	Axis 4	±6.28 rad (±360°)				
	Axis 5	±2.36 rad (±135°)		±2.27 rad (±130°)		
	Axis 6	±6.28 rad (±360°)				
Maximum Velocity	Axis 1	2.37 rad/s (136°/s)	2.18 rad/s (125°/s)	2.01 rad/s(115°/s)	1.83 rad/s (105°/s)	1.75 rad/s (100°/s)
	Axis 2	2.36 rad/s (135°/s)	2.01 rad/s (115°/s)	1.83 rad/s(105°/s)	1.57 rad/s (90°/s)	1.57 rad/s (90°/s)
	Axis 3	2.36 rad/s (135°/s)	2.11 rad/s (121°/s)	1.97 rad/s(113°/s)	1.74 rad/s (100°/s)	1.66 rad/s (95°/s)
	Axis 4	4.19 rad/s (240°/s)	3.14 rad/s (180°/s)	2.44 rad/s(140°/s)	2.27 rad/s (130°/s)	2.18 rad/s (125°/s)
	Axis 5	4.07 rad/s (233°/s)	3.02 rad/s (173°/s)	2.32 rad/s(133°/s)	2.18 rad/s (125°/s)	2.18 rad/s (125°/s)
	Axis 6	6.13 rad/s (351°/s)	4.54 rad/s (260°/s)	3.49 rad/s(200°/s)	3.40 rad/s (195°/s)	3.32 rad/s (190°/s)
Maximum payload	Wrist	100 kg	166 kg	210 kg	240 kg	250 kg
	Forearm *1	45 kg (90 kg at maximum)			20 kg (45 kg at maximum)	
Maximum static load torque	Axis 4	580 N·m	951 N·m	1,337 N·m		
	Axis 5	580 N·m	951 N·m	1,337 N·m		
	Axis 6	290 N·m	490 N·m	720 N·m		
Maximum moment of inertia *2	Axis 4	60 kg·m ²	88.9 kg·m ²	141.1 kg·m ²		225.4 kg·m ²
	Axis 5	60 kg·m ²	88.9 kg·m ²	141.1 kg·m ²		225.4 kg·m ²
	Axis 6	30 kg·m ²	45.0 kg·m ²	79.0 kg·m ²		196.0 kg·m ²
Position repeatability *3		±0.06 mm				
Mounting Condition		Floor				
Ambient conditions		Temperature: 0 to 45 °C *4 Humidity: 20 to 85%RH (No dew, nor frost allowed) Vibration to the installation face: Not more than 0.5G (4.9 m/s ²)				
Protection class		Wrist ; IP67 equivalent, Body ; IP54 equivalent,				
Noise *5		79.6 dB				
Robot weight		960 kg		990 kg		1030 kg

1[rad] = 180/π[°], 1[N·m] = 1/9.8[kgf·m]

- Axis 1 - Axis 6 are displayed as J1-J6 each on the controller screen.
- Specifications are subject to change without prior notice for technical changes.
- Explosion-proof version is not available.

*1: This value changes due to the placement and load conditions of a wrist. *2: Maximum moment of inertia of a wrist changes due to the load condition. *3: JIS B 8432 conformance. *4: Using at 1000m or lower sea level. Ambient temperature has limitations when allowable altitude is exceeded. *5: Robot noise is A-weighted equivalent sound level measured under "JIS Z 8737-1" (ISO 11201) with maximum payload and maximum velocity.

A-Trac4 type

Basic specifications when cable support "A-trac4" is equipped (only difference from standard type)

Item		Specifications		
Robot type		SRA100-01A	SRA166-01A	SRA210-01A
Maximum Motion range	Axis 4	±3.67 rad (±210°)		
	Axis 5	±2.09 rad (±120°)		
	Axis 6	±3.58 rad (±205°)		
Maximum payload	Forearm *1	15 kg (60 kg at maximum)		
Robot weight		1,060 kg		1,090 kg

*1: This value changes by placement and load conditions of a wrist.

Long arm type

Item		Specifications		
Robot type		SRA120EL-01	SRA133L-01	SRA166L-01
Structure		Articulated		
Degree of Freedom		6		
Drive system		AC servo motor		
Maximum Motion range	Axis 1	±3.14 rad (±180°)		
	Axis 2	-1.40 ~ +1.05 rad(-80 ~ +60°)		
	Axis 3	-2.23 ~ +2.62 rad (-127.7 ~ +150°)	-2.33 ~ +2.62 rad (-133.4 ~ +150°)	
	Axis 4	±6.28 rad (±360°)		
	Axis 5	±2.36 rad (±135°)		
	Axis 6	±6.28 rad (±360°)		
Maximum Velocity	Axis 1	2.01 rad/s(115 °/s)	2.18 rad/s(125 °/s)	2.01 rad/s(115 °/s)
	Axis 2	1.83 rad/s(105 °/s)	2.01 rad/s(115 °/s)	1.83 rad/s(105 °/s)
	Axis 3	1.97 rad/s(113 °/s)	2.11 rad/s(121 °/s)	1.97 rad/s(113 °/s)
	Axis 4	2.44 rad/s(140 °/s)		
	Axis 5	3.02 rad/s(173 °/s)		
	Axis 6	4.54 rad/s(260 °/s)		
Maximum payload	Wrist	120 kg	133 kg	166 kg
	Forearm *1	45 kg (90 kg at maximum)		
Maximum static load torque	Axis 4	687 N·m	800 N·m	951 N·m
	Axis 5	687 N·m	800 N·m	951 N·m
	Axis 6	353 N·m	400 N·m	490 N·m
Maximum moment of inertia *2	Axis 4	60 kg·m ²	76 kg·m ²	88.9 kg·m ²
	Axis 5	60 kg·m ²	76 kg·m ²	88.9 kg·m ²
	Axis 6	30 kg·m ²	38 kg·m ²	45.0 kg·m ²
Position repeatability *3		±0.06 mm		
Mounting Condition		Floor		
Ambient conditions		Temperature: 0 to 45 °C *4 Humidity: 20 to 85%RH (No dew, nor frost allowed) Vibration to the installation face: Not more than 0.5G (4.9 m/s ²)		
Protection class		Wrist ; IP67 equivalent, Body ; IP54 equivalent,		
Noise *5		79.6 dB		
Robot weight		985kg	980 kg	

1[rad] = 180/π[°], 1[N·m] = 1/9.8[kgf·m]

- Axis 1 - Axis 6 are displayed as J1-J6 each on the controller screen.
- Specifications are subject to change without prior notice for technical changes.
- Explosion-proof version is not available.

*1: This value changes due to the placement and load conditions of a wrist. *2: Maximum moment of inertia of a wrist changes with load conditions of a wrist. *3: JIS B 8432 conformance. *4: Using at 1000m or lower sea level. Ambient temperature has limitations when allowable altitude is exceeded. *5: Robot noise is A-weighted equivalent sound level measured under "JIS Z 8737-1" (ISO 11201) with maximum payload and maximum velocity.

3. Robot dimensions and Motion range

【SRA100-01】 【SRA166-01】

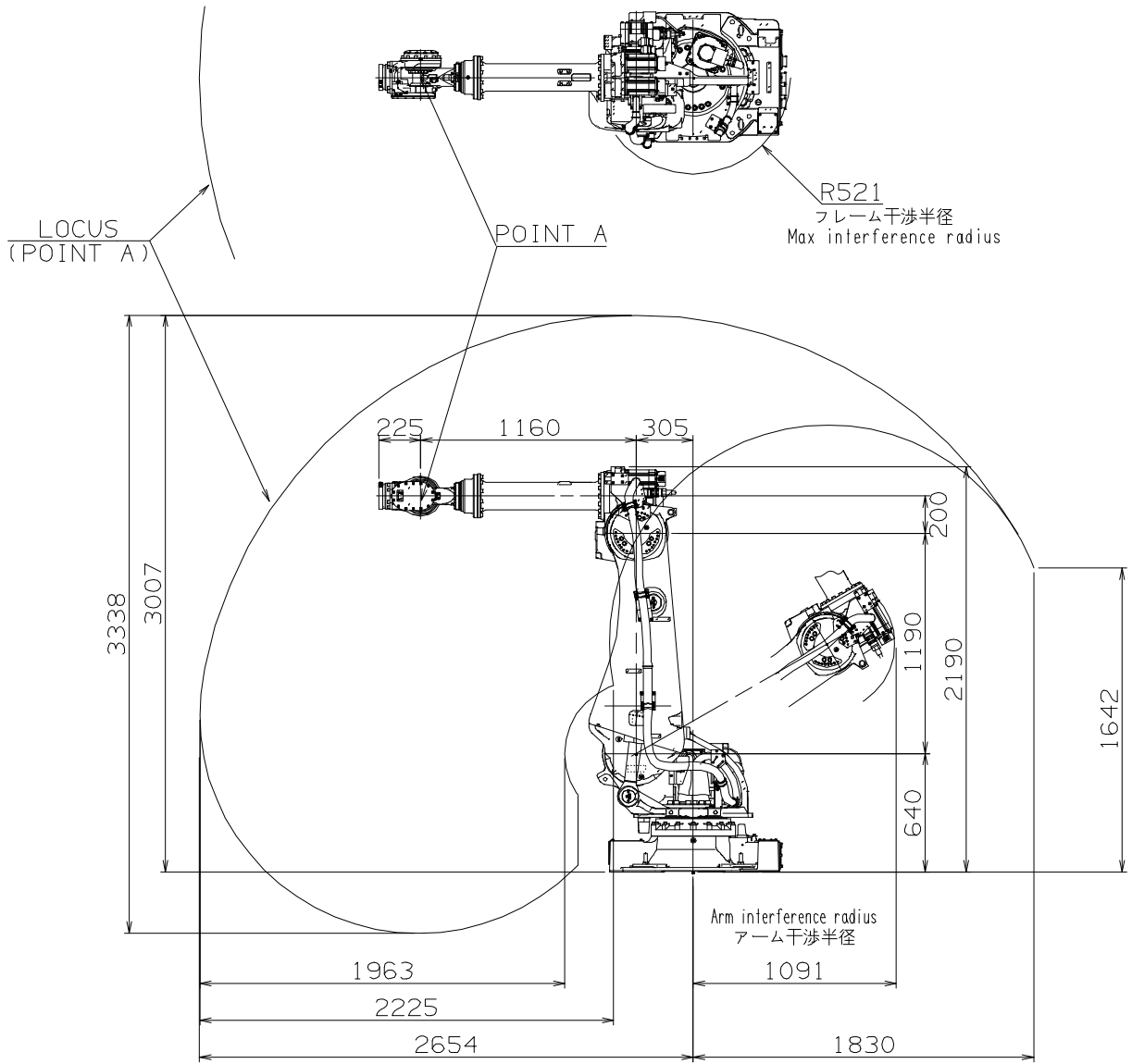

【SRA210-01】【SRA240-01】

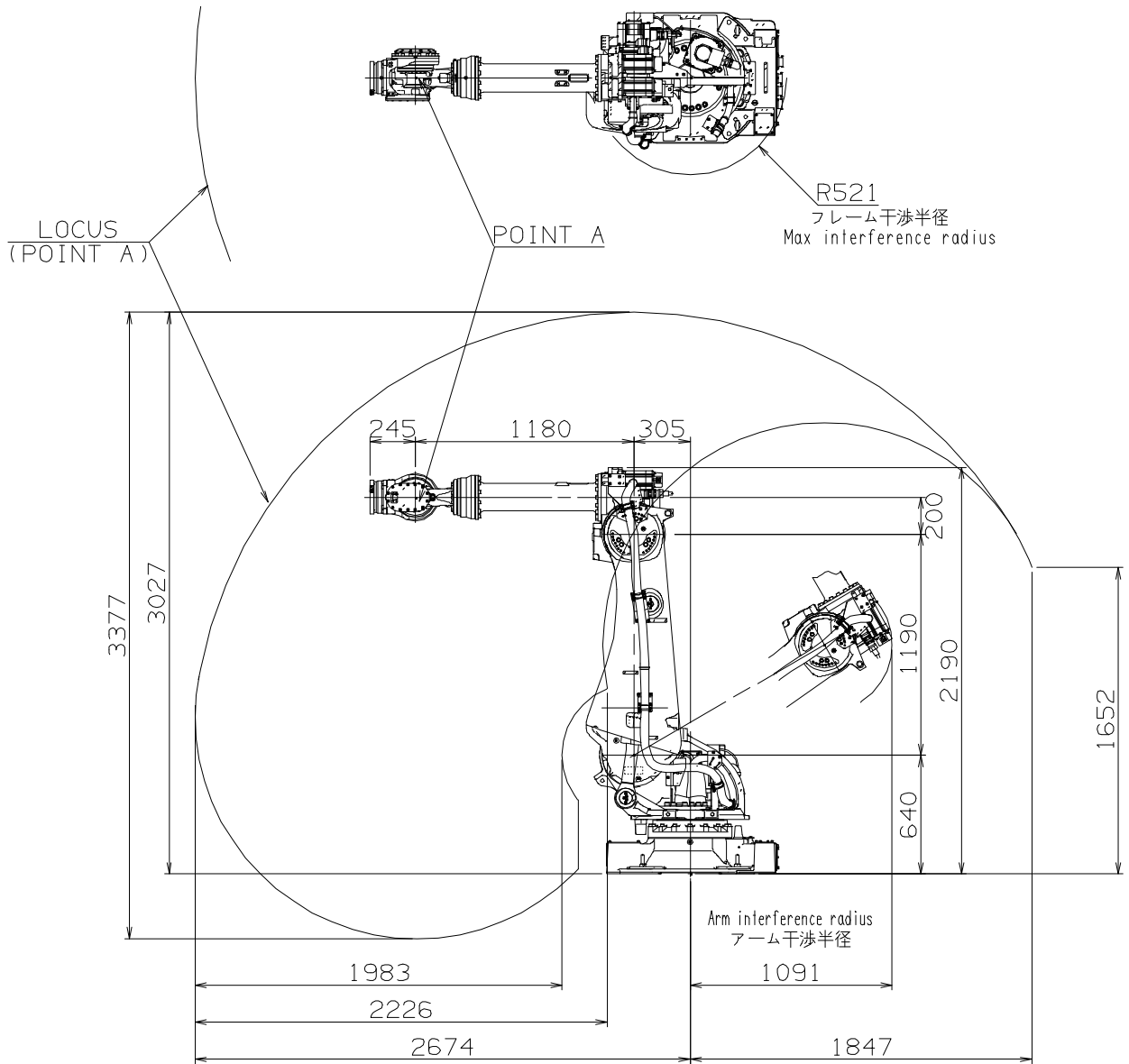

【SRA250-01】

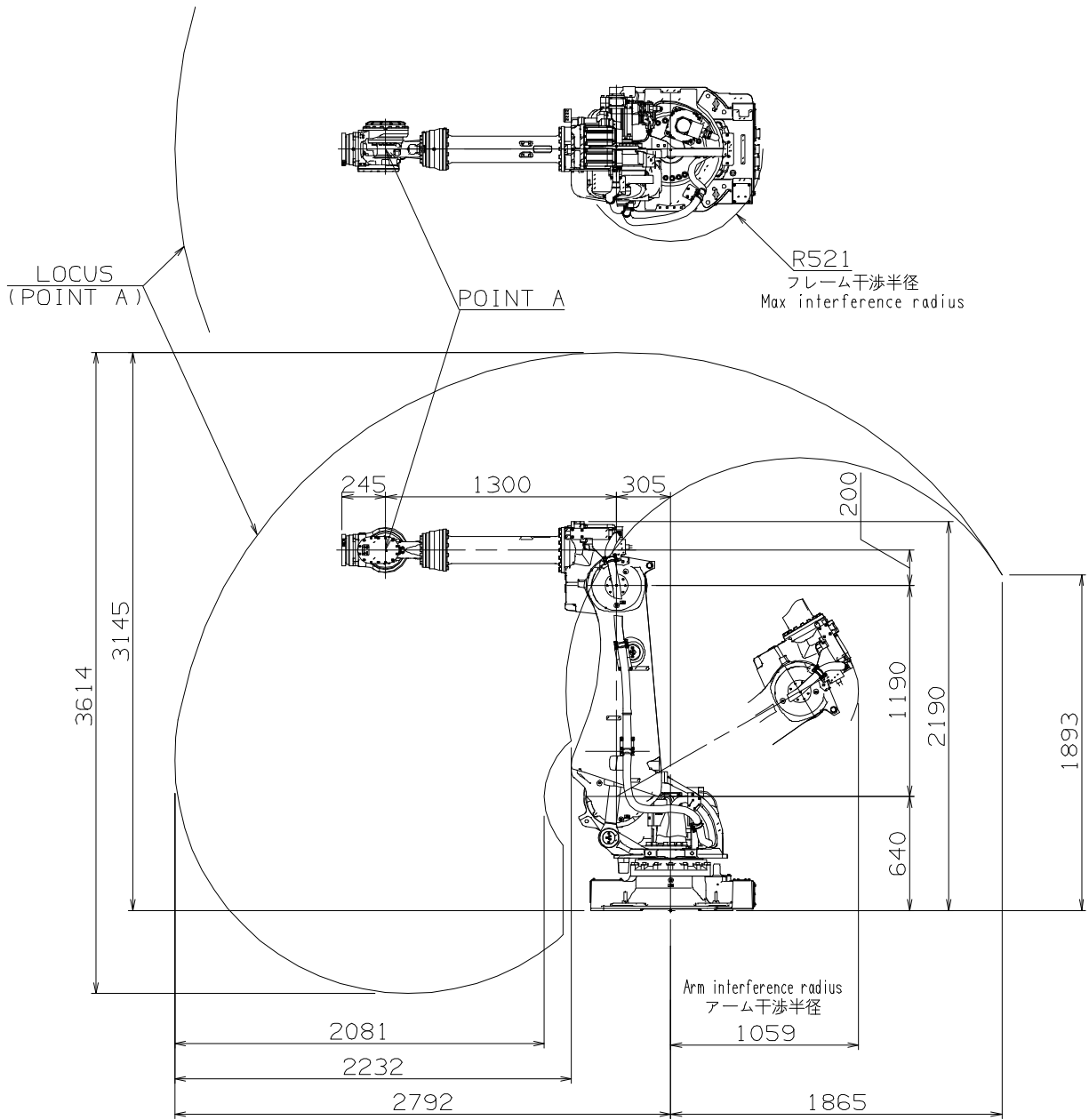

【SRA100-01A】 【SRA166-01A】

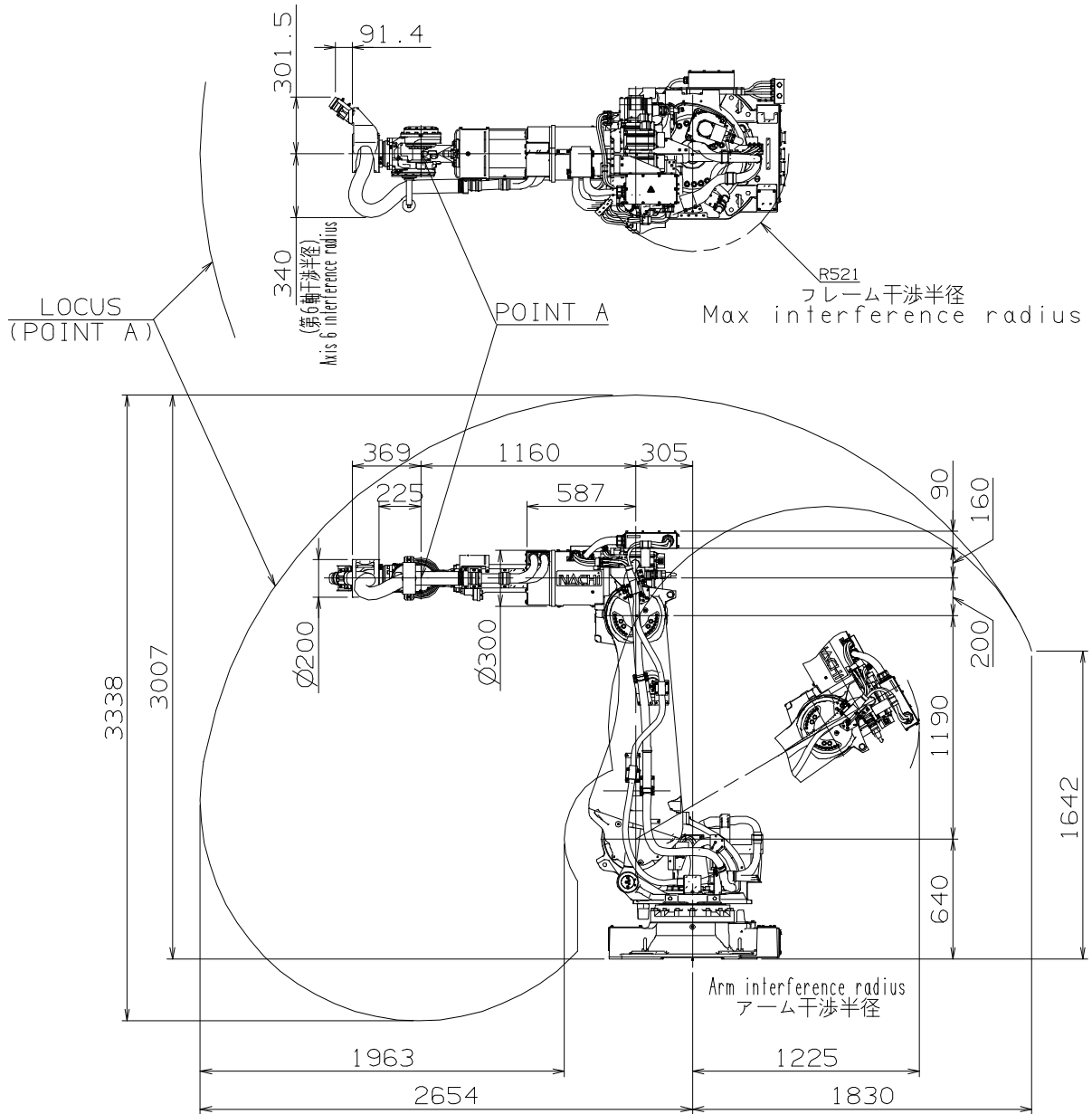

This figure is for the robot equipping the cable support (A-trac4) on the arm for spot welding application.

【SRA210-01A】

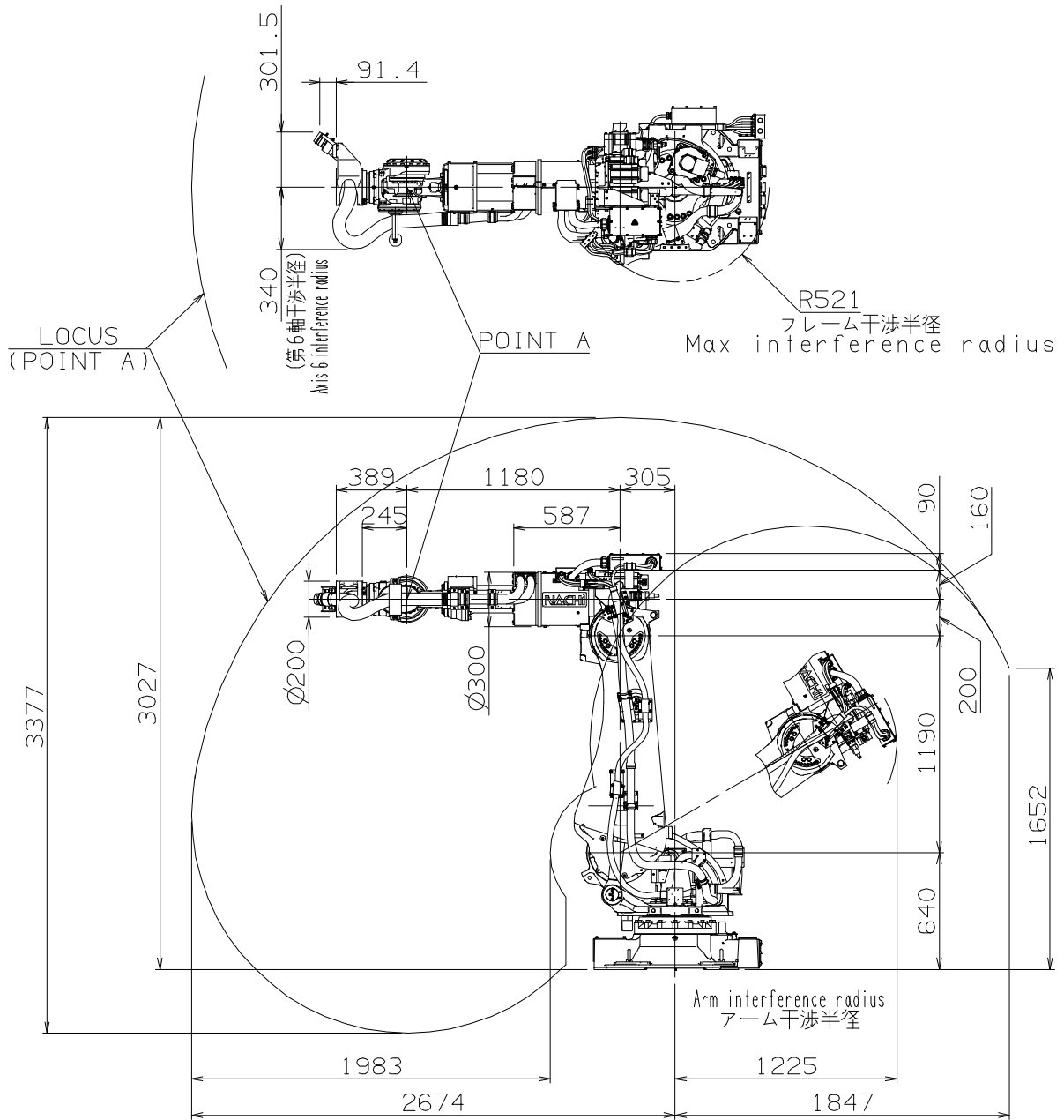

This figure is for the robot equipping the cable support (A-trac4) on the arm for spot welding application.

【SRA120EL-01】

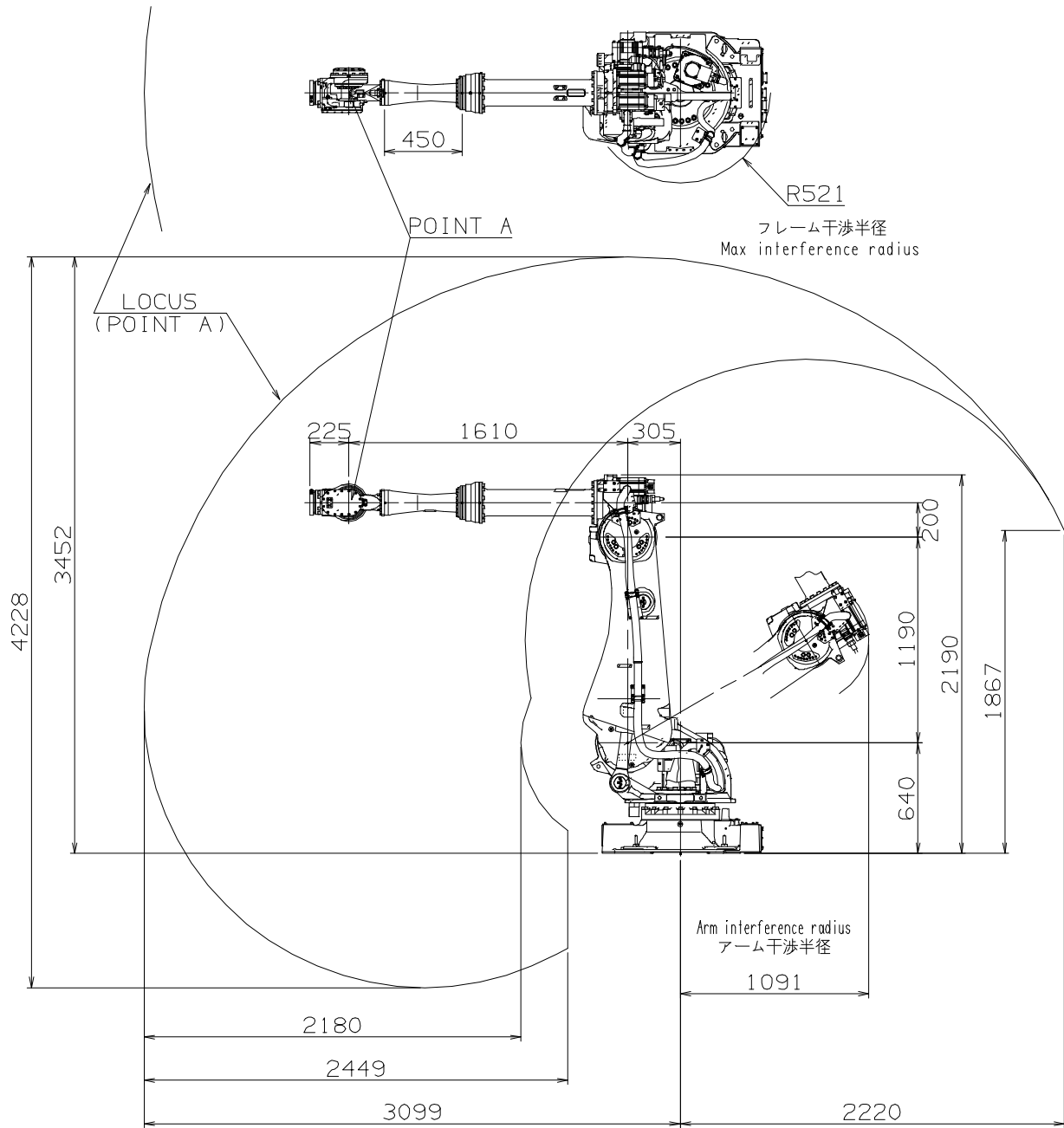

【SRA133L-01】 【SRA166L-01】

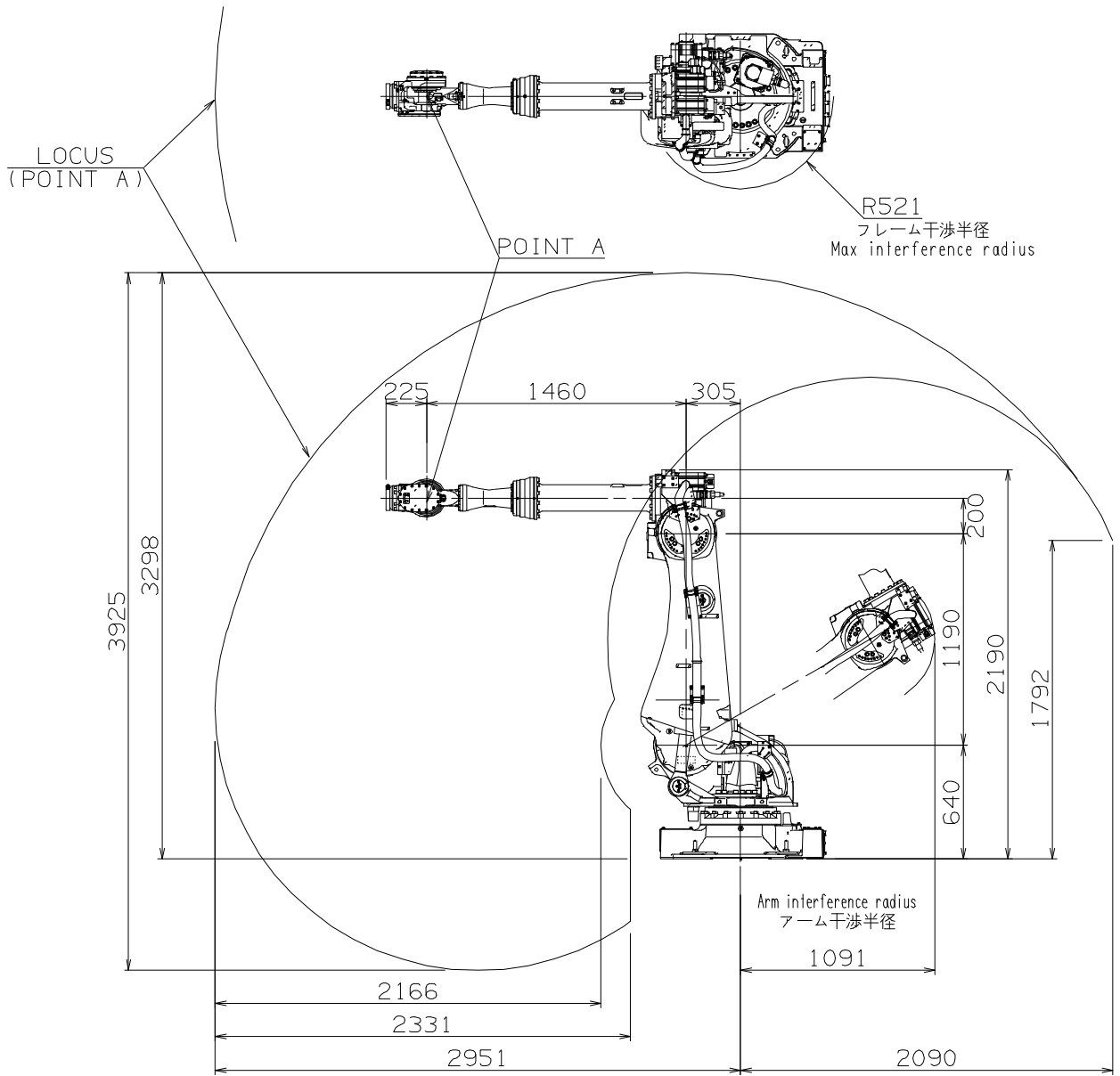

4. Detail of load mounting face

■ Wrist

For the end effector fixing bolts, use the mounting P.C.D. shown in the following figures.
Another P.C.D. is prepared as option. Consult with each NACHI-FUJIKOSHI office for the details.



Be sure to screw the M10 tool fixing bolts in the wrist not deeper than the screw depth in the mounting face. Screwing the bolts deeper than the screw depth may damage the wrist.

【SRA100-01】【SRA166-01】【SRA120EL-01】【SRA133L-01】【SRA166L-01】



Use the mounting P.C.D.125 when tool weight is 100 kg or more.

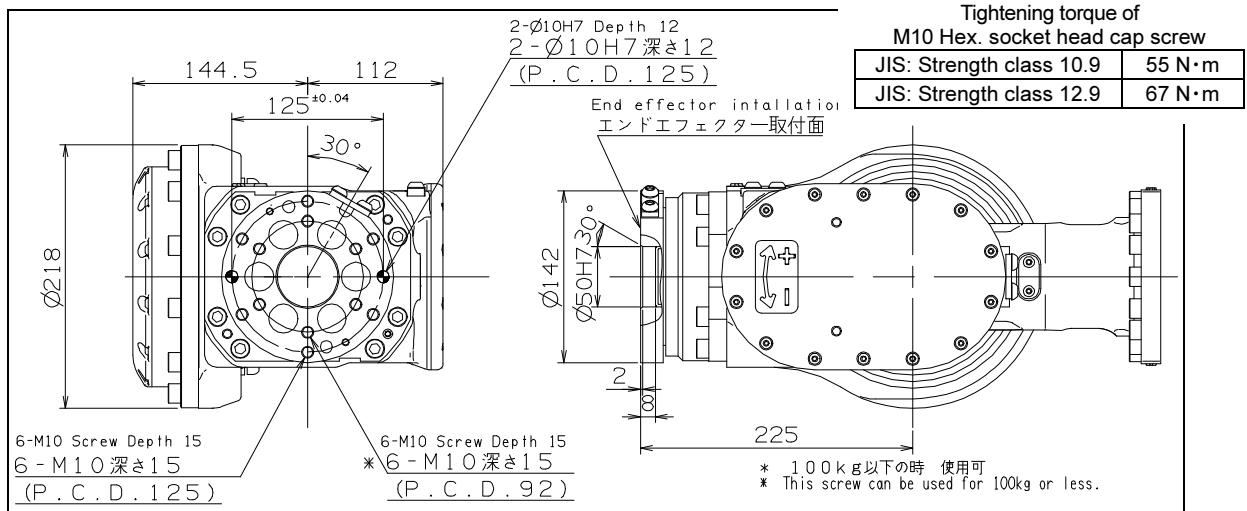



【SRA210-01】【SRA240-01】【SRA250-01】

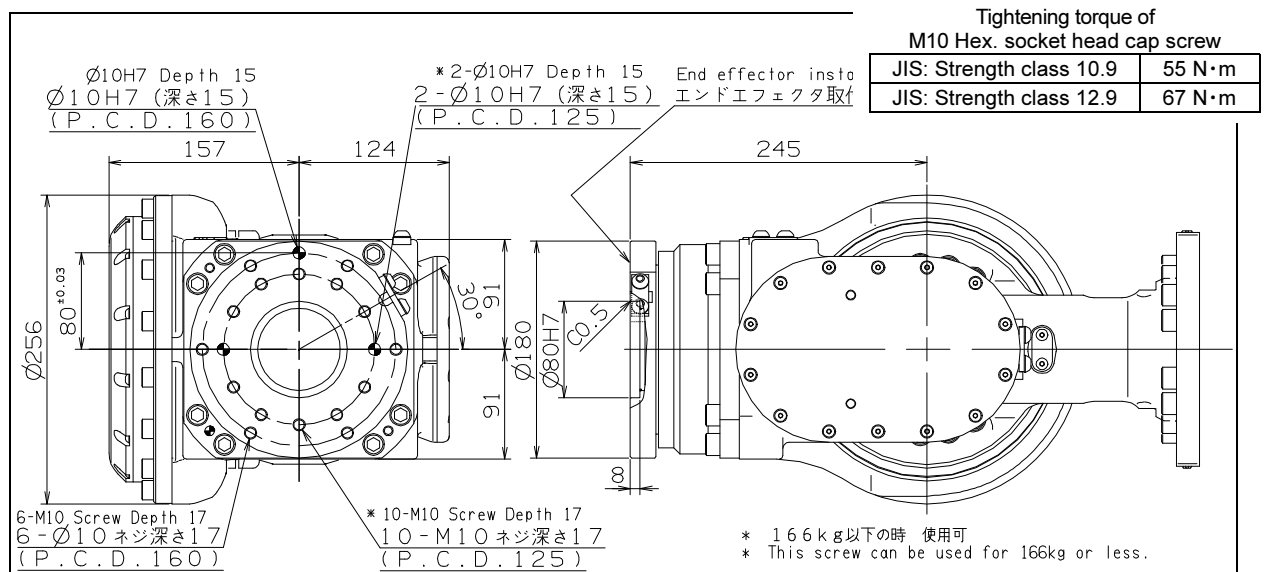

Use the mounting P.C.D.160 when tool weight is 166 kg or more.



 CAUTION	Be sure to screw the M10 tool fixing bolts in the wrist not deeper than the screw depth in the mounting face. Screwing the bolts deeper than the screw depth may damage the spring and cable inside of A-Trac4.
 IMPORTANT	Use the mounting P.C.D.125 or 160 when tool weight is 100 kg or more. (Only when the customer doesn't consider strength of the bolt.)

【SRA100-01A】【SRA166-01A】

- * 166kg以下の時 使用可 (P.C.D.125)
- * This screw can be used for 166kg or less.
- # 100kg以下の時 使用可 (P.C.D.92)
- # This screw can be used for 100kg or less.

Oblique line area is working envelope of A-Trac4 spring.
 Working envelope of tool should be outside of this area,
 otherwise tool may be broken by the interference with A-Trac4 spring.
 Moreover, this interference will cause the damage to the cables inside of A-Trac4 spring.
 Mesh area is where the tool (end effector) can be mounted.

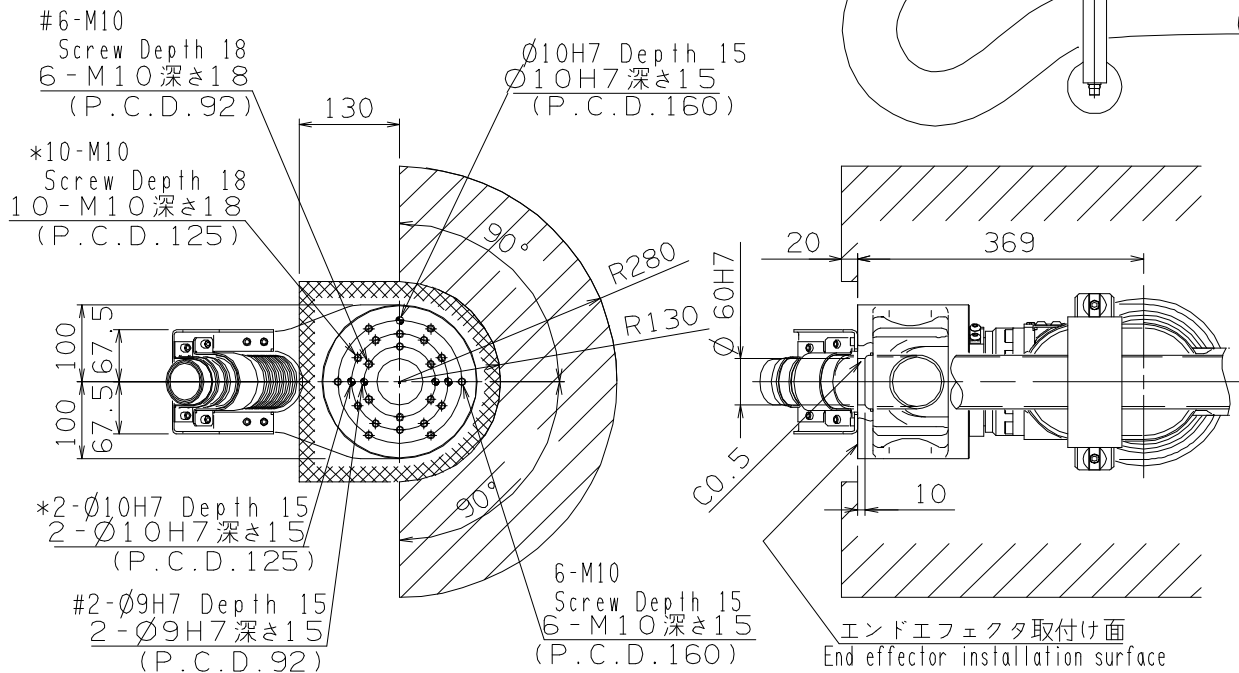
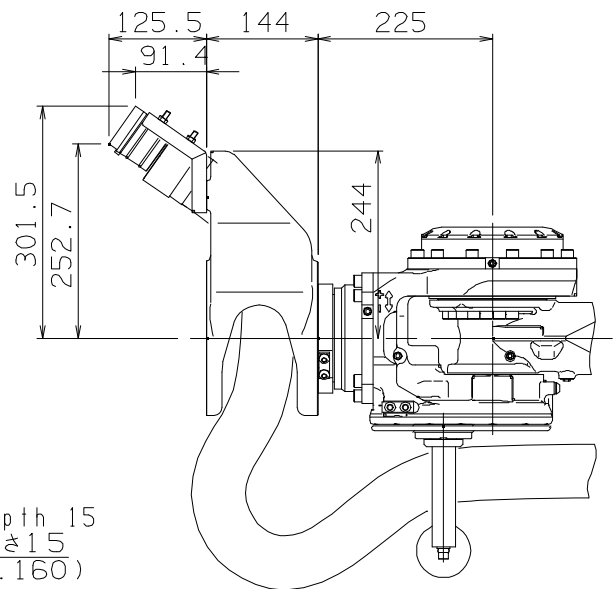

【SRA210-01A】

- \$ 210kg以下の時 使用可 (P.C.D.160)
- \$ This screw can be used for 210kg or less.
- * 166kg以下の時 使用可 (P.C.D.125)
- * This screw can be used for 166kg or less.
- # 100kg以下の時 使用可 (P.C.D.92)
- # This screw can be used for 100kg or less.

Oblique line area is working envelope of A-Trac4 spring.
Working envelope of tool should be outside of this area,
otherwise tool may be broken by the interference with A-Trac4
spring.

Moreover, this interference will cause the damage to the
cables inside of A-Trac4 spring.

Mesh area is where the tool (end effector) can be mounted.

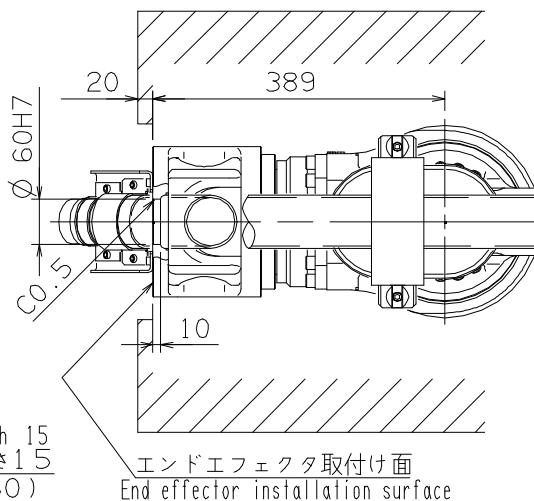
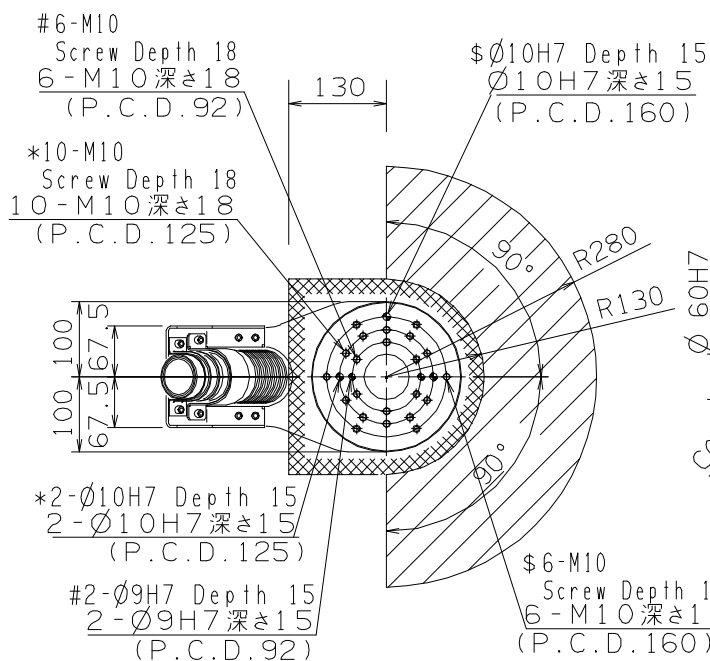
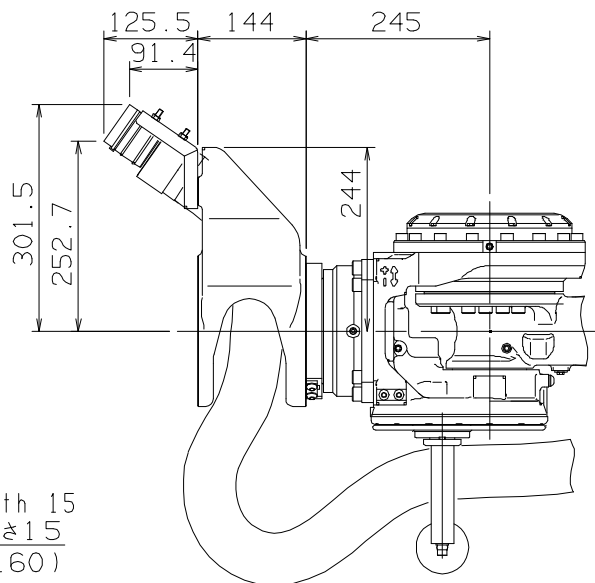

■ Upper part of forearm

Ancillary equipment can be mounted to the upper part of robot forearm.
 In case of A-Trac4 model, screw holes of 4-M8 depth 12 marked ※ cannot be used because they are hidden in the cover part.

【SRA100-01】 【SRA166-01】 【SRA210-01】
 【SRA240-01】 【SRA100-01A】 【SRA166-01A】
 【SRA210-01A】 【SRA120EL-01】 【SRA133L-01】
 【SRA166L-01】

【SRA250-01】

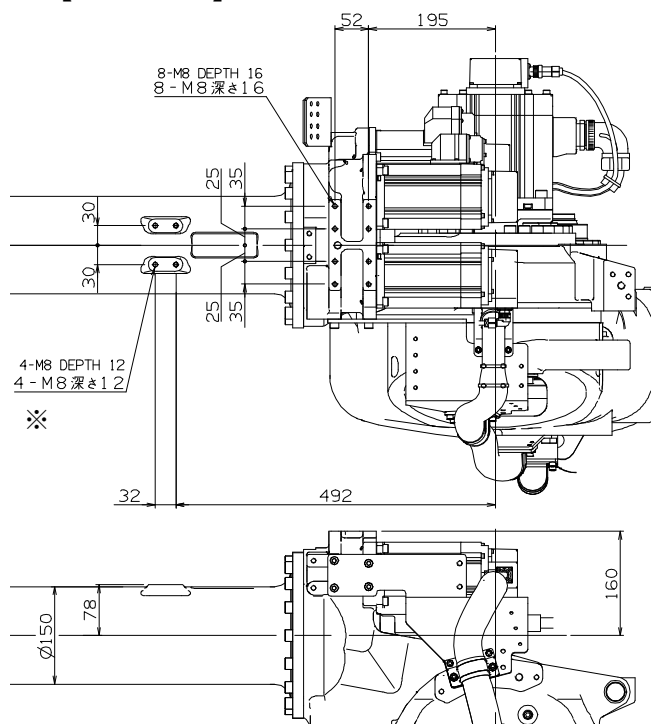
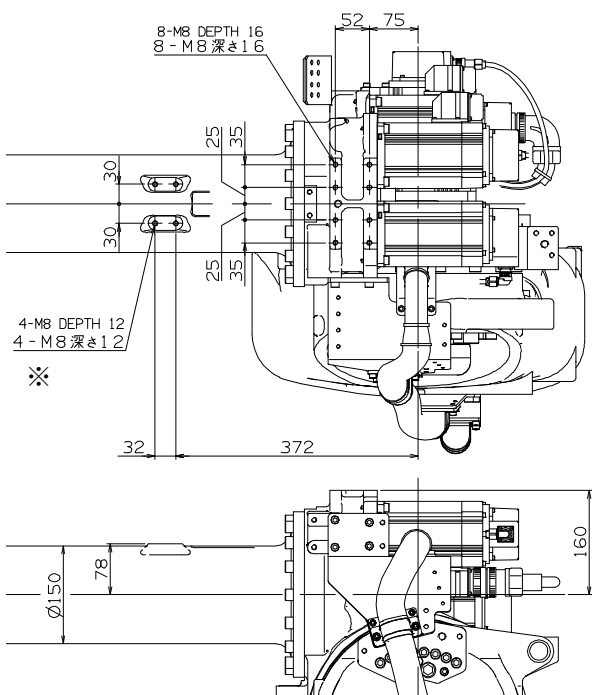



5. Installation procedure

The installation location and the installation procedure of the robot are critical factors to maintain robot functions. The ambient conditions of installation location not only have influence on the life of mechanical sections of the robot, but also get involved in safety issues. Consequently, strictly observe the environmental conditions shown below. Furthermore, utmost care should be exerted for the installation procedure and the foundation for the robot in order to maintain the robot performance. Strictly observe the installation procedure for the robot provided below.

■ Safety measures against entry in the robot operating area





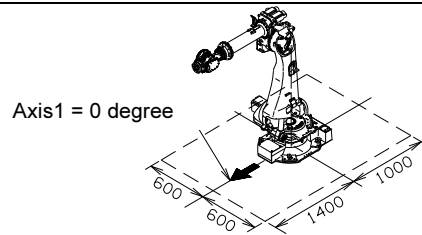

 WARNING	While the robot is in operation, workers are in danger of coming in contact with the robot. To avoid that, install a guard fence so as to keep the worker away from the robot. Not doing so will cause the workers or other persons to accidentally enter the operating area, thus resulting in accidents.
--	---

■ Safety measures for the robot and peripheral equipment locations

 WARNING	Do not install the operation and the adjustment part within the robot operating area. Install the robot control panel, interlock panel, and all the other operation panels where it's safe, so that they can be operated outside of the guard fence . In case those operation panels are installed near the robot, workers can get caught in the robot, when the robot operation fails.
 IMPORTANT	When installing this robot, minimum work space is necessary for maintenance work. Such as motor replacement, balancer replacement and so on. (*Refer to this drawing.)





■ Safety measures for installation work

 WARNING	To install the robot, it is important to install the robot so that no workers will get pinched or hurt by the robot or a device around them. The robot must not operate in the maximum operating range with a tool equipped on, and make sure not to touch any peripheral equipment.
 WARNING	Be sure to install the robot according to the specified procedure. Otherwise possibilities occur that robot's base may move or robot may fall over while in operation.
 WARNING	You must fully understand the connection procedure to make proper wire connections between the robot and the controller or the robot and the peripheral equipment. Not following the proper procedure will cause the malfunction of the robot.
 WARNING	Be sure to establish a proper grounding for the robot. If the equipment makes substantial noises such as a welder, conduct the specified grounding construction for the equipment.
 WARNING	Please pay extra attention not to damage wirings during transportation or installation of the robot. Furthermore, after installing the robot, apply protective guards to wirings so that it won't be damaged by workers or other persons, or forklift trucks or any other.
 WARNING	Installation structures (robot raiser, etc.) may cause problems such as vibration and servo tracking error. If such problem occurs, please promptly improve the installation structure. If installation structures are kept using as they are, reliability and lifetime of not only the robot but also the installation structures may be damaged, due to the vibration and sudden braking of robot.

■ Installation location and ambient conditions

Conditions (temperature, humidity, height and vibration) are written in “2. Basic Specifications”. Further ambient conditions listed below must be observed.

- (1) Location with the drainage structure so that swivel base is not flooded, when the liquid such as water or cutting fluid is splashed on the robot body
- (2) Location with no flammable or corrosive fluid or gas.
- (3) Type D grounding (the grounding resistance is 100Ω or less) is necessary.

 IMPORTANT	Our company's robot, controller and related option equipment are designed for general industrial use. Unless otherwise specified in the specifications or manuals, operations in special conditions and environments such as outdoor, X-ray environment, radiation environment, nuclear power control, aerospace equipment, public transportation, medical equipment, etc. are not assumed. Our company and its subsidiaries are not liable for any accidents, failures, etc., that may occur if the robot is used in such an environment without asking our company to do so.
 IMPORTANT	Using mounting condition that does not comply with specifications may cause the robot system to malfunction or fail prematurely. In that case, robot will be out of warranty. Please understand it in advance.

■ Installation procedure

While robot moves, large reaction force is applied to the swiveling base from all directions. Consequently, the robot should be installed in such a manner that the foundation endures not only the static loads but also the reaction force caused by robot movement.

Repair uneven spots, cracks, and others on the floor, and then install the robot by following to the table below. If thickness of floor concrete is less than needed level, an independent foundation should be constructed. Inspect the foundation prior to the robot installation, and then construct the foundation, if necessary.

Robot Model	SRA100-01 SRA100-01A	SRA166-01 SRA166-01A SRA133L-01	SRA210-01 SRA210-01A SRA120EL-01 SRA166L-01	SRA240-01	SRA250-01
Thickness of floor concrete	Not less than 160 mm				
Installation parts *1	8 bolts of M20 (JIS: Strength class 12.9) not less than 65mm 8 plain washers of not less than 4.5 mm in thickness and HRC35 in hardness				
Tightening torque *2	560 ± 30 N·m				
Allowable repeated tensile *3	Appx. 18,000 N	Appx. 22,000 N	Appx. 28,000 N	Appx. 30,000 N	Appx. 32,000 N



*1 : Installation parts are not accessory of robot.

*2 : Apply a coating of lubricating oil to the threaded parts of bolts, and then tighten bolts by using torque wrench to the specified tightening torque.

*3 : This tensile is per installation bolt when robot is installed with all bolts written in table above.

■ Installation space

To install the robot, lock the swiveling base of the robot.

 CAUTION	The mechanical stopper end is located in a position exceeding the specified working envelope (software limit) of axis 1 by 3°. To install the safety fence, with consideration given to the wrist configuration and the shape of end effector.
 WARNING	On axes 1, 2 and 3, the robot working envelope can be regulated for safety (optional function). Since optional parts should be installed to enable this function, do not independently move the standard parts (e.g. mechanical stopper).
 WARNING	If mechanical stopper collides and robot stops, it's possible that some parts are already damaged, for example, mechanical stopper is transformed or fixing bolts are broken. In this case, sufficient intensity and function can not be kept. Mechanical stopper and reduction gear of collided joint are needed to be replaced to the new one.

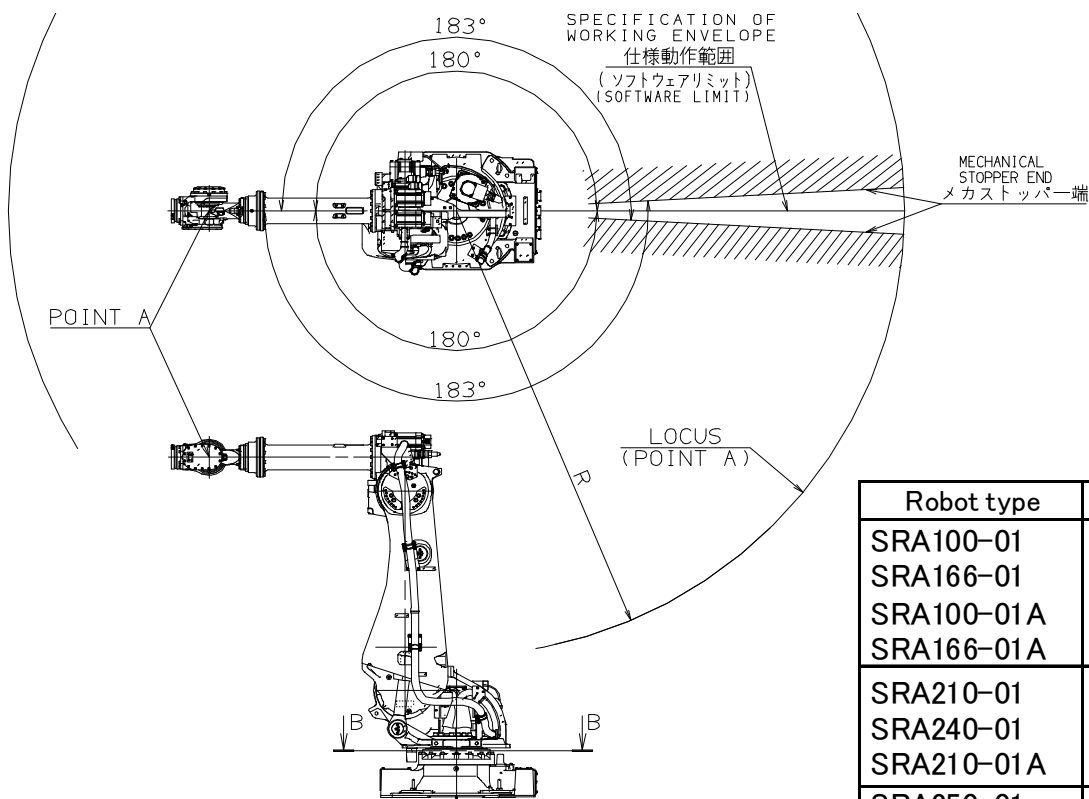

Robot type	R
SRA100-01 SRA166-01 SRA100-01A SRA166-01A	2654
SRA210-01 SRA240-01 SRA210-01A	2674
SRA250-01	2792
SRA120EL-01	3099
SRA133L-01 SRA166L-01	2951

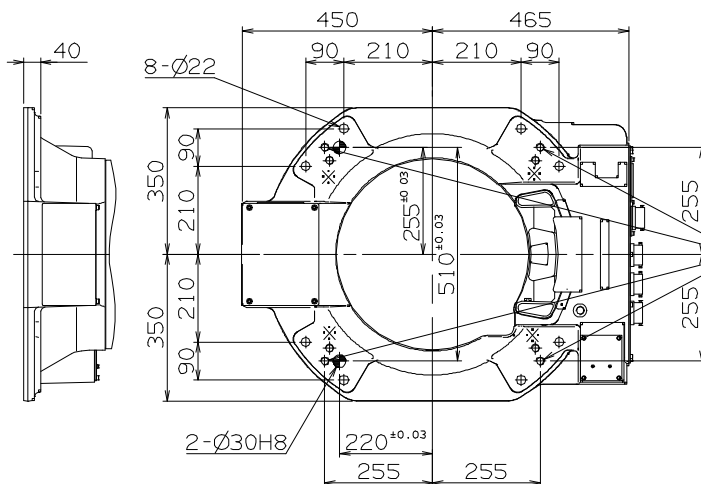

4-M20
ジャッキボルト使用時
吊りボルトを取外してください。
Remove eye bolts when
use jack bolts.

※印のタップを
ジャッキボルト
には、使用しな
いでください。
Do not use tap
holes marked
with symbol ※
for jack bolts.

断面B-B
Section B-B

■ Accuracy of installation surface

When installing robot, strictly observe precautions listed below to cause no deformation in the swivel base.

- (1) Make the deviation from the flatness of the 4 plates on the robot installation surface fall within 1.0 mm.
- (2) Make the deviation in height between the 4 places of each base plate installation surface and the robot installation surface fall in the range of 1.0 mm (± 0.5 mm).

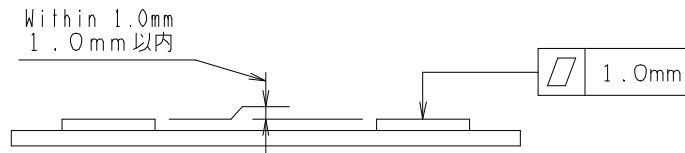

- (3) If the two precautions above cannot be observed, use jack bolts to bring the four places into even contact with the installation surface.

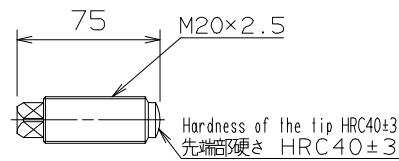

■ Welding of base plate

Protect the space (4 places of the front, back, left and right) on robot bottom and installed side by the cover etc. as follows when you weld with the base plate installed in the robot body by the welding spatter and the spark, etc. so that wiring in the robot should not receive damage. After welding the outer line, once remove the robot and weld the inner line.

Temporary install the robot, and weld the outer line of base plate.

Once remove the robot and weld the inner line.

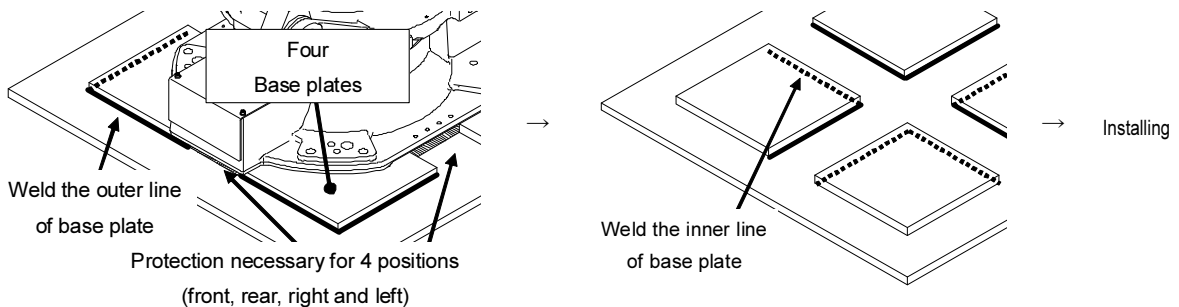

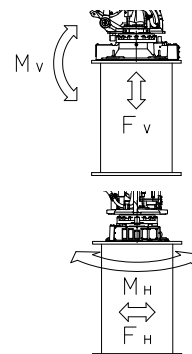

■ Maximum robot generative force

Robot model	Max. vertical generative force F_v	Max. horizontal generative force F_H	Max. vertical generative moment M_v	Max. horizontal generative moment M_H
SRA100-01 SRA100-01A	40,400 N	29,400 N	71,400 N·m	60,900 N·m
SRA133L-01	43,500 N	31,800 N	88,200 N·m	75,700 N·m
SRA166-01 SRA166-01A	46,800 N	35,200 N	92,300 N·m	79,700 N·m
SRA210-01 SRA210-01A SRA120EL-01 SRA166L-01	52,800 N	40,500 N	113,200 N·m	98,300 N·m
SRA240-01	56,300 N	43,700 N	122,000 N·m	106,300 N·m
SRA250-01	58,100 N	45,100 N	130,000 N·m	113,300 N·m



6. Allowable wrist load

 <p>CAUTION</p>	<p>The wrist load is regulated by “Maximum payload”, “Maximum static load torque”, and “Maximum moment of inertia”. If wrist load exceeds beyond these allowable values, WE CANNOT GUARANTEE THE FUNCTION OF THE ROBOT.</p> <p>Please refer to “2. Basic specifications” and following figures for the detail.</p>
 <p>CAUTION</p>	<p>Before using the robot, please register the "weight", "COG (center of gravity) position" and "inertia Moment" of wrist payload as the load condition. Robot is controlled to minimize the operating time according to the registered value.</p> <p>Therefore, even if the load condition was within the specifications, if that is incorrect, excessive acceleration will be generated, and reliability and life may be damaged.</p> <p>Even if the correct value is registered, vibration or servo tracking error may occur due to the insufficient rigidity of the payload. If such problem occurs, please adjust the “speed”, “acceleration” and “smoothness”. Those factors can be adjusted in every step. See the instruction manual for details.</p> <p>FD controller instruction manual BASIC OPERATIONS (TCFEN-002) 4.3 Teaching</p>

■ Torque map

C.O.G. of wrist load should exist inside the range shown below.

【SRA100-01】

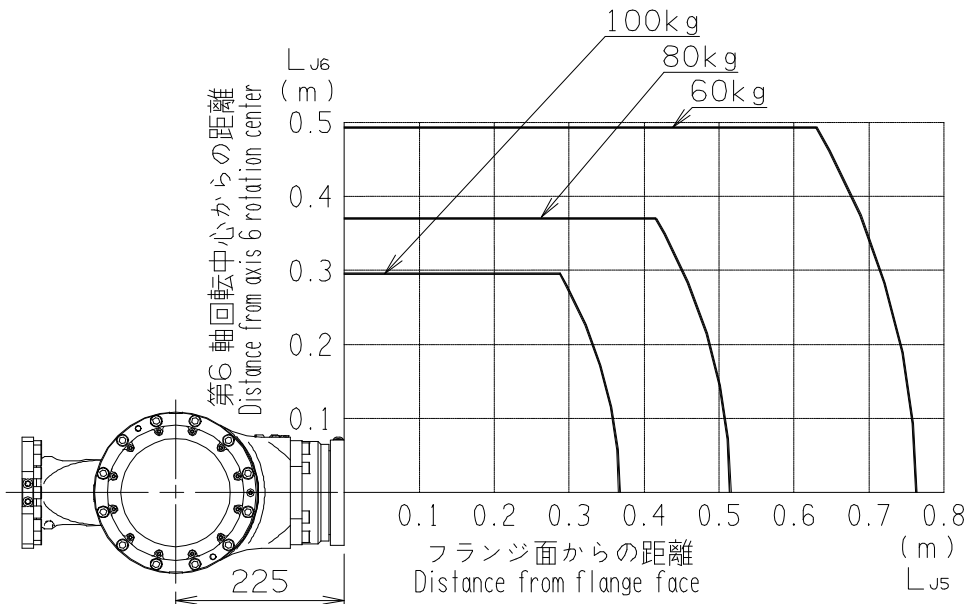

【SRA100-01A】

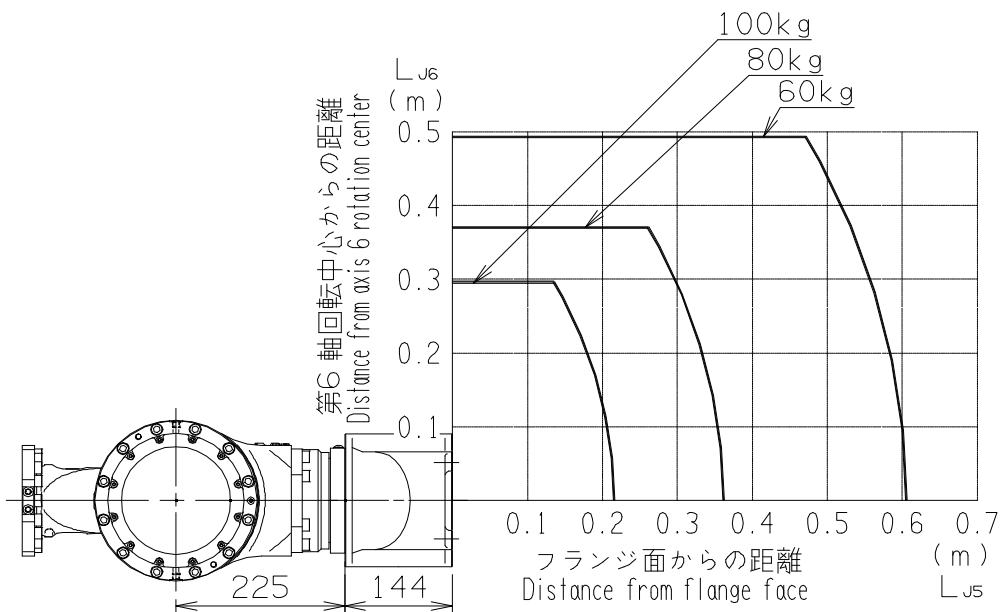

【SRA166-01】
【SRA166L-01】

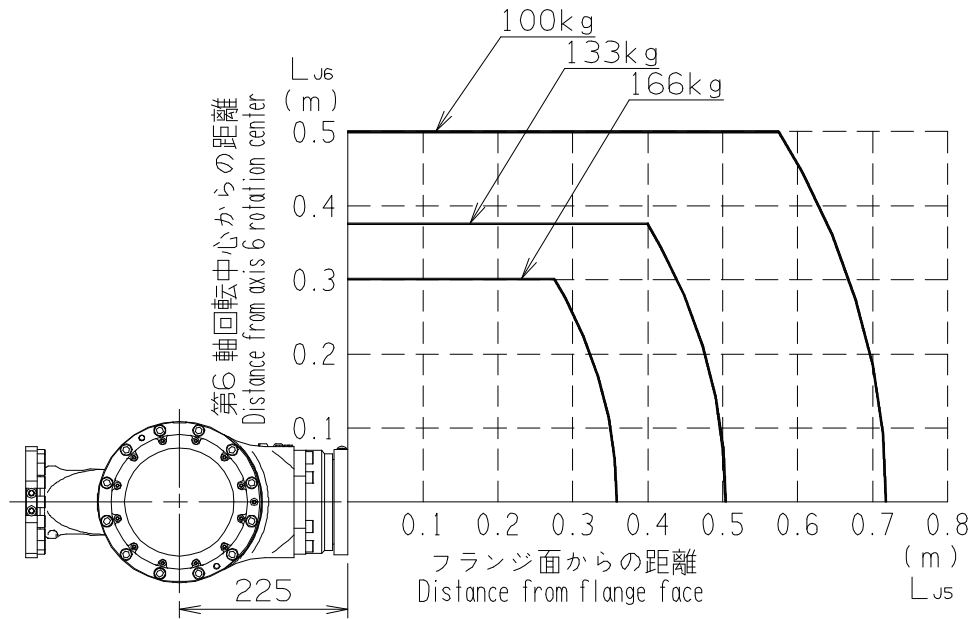

【SRA166-01A】

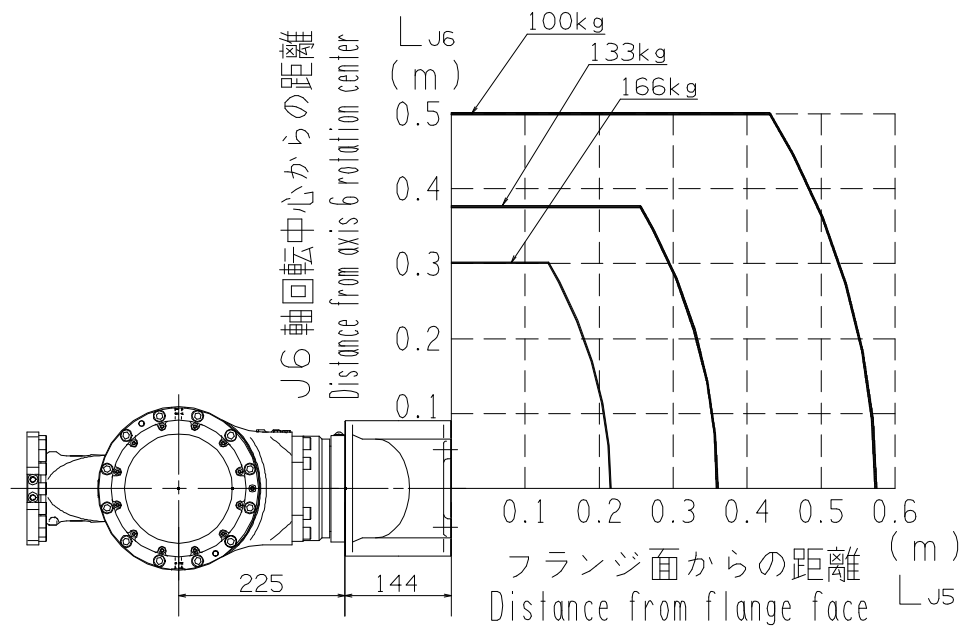

【SRA210-01】

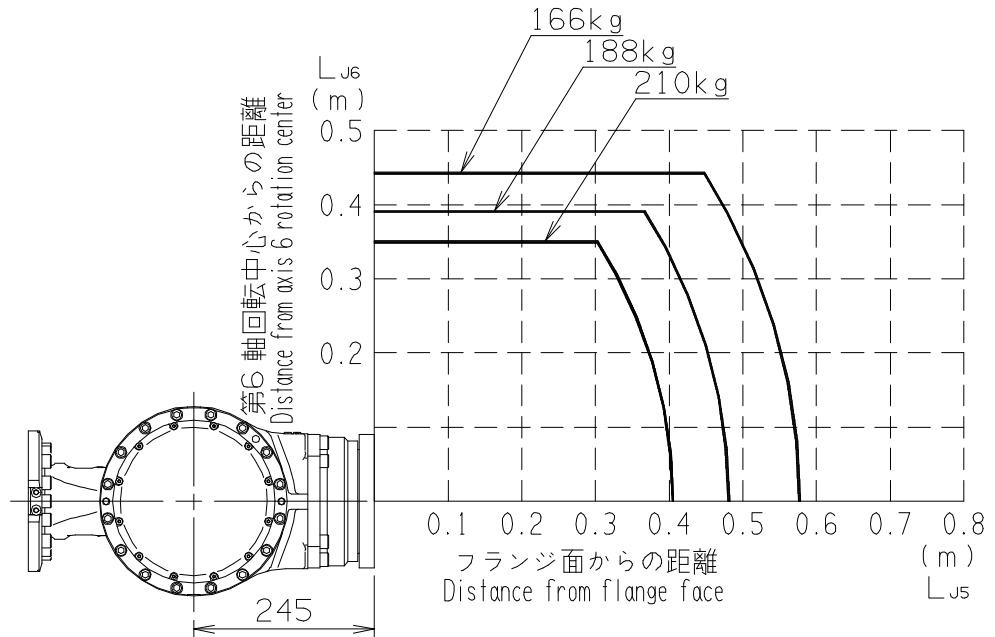

【SRA210-01A】

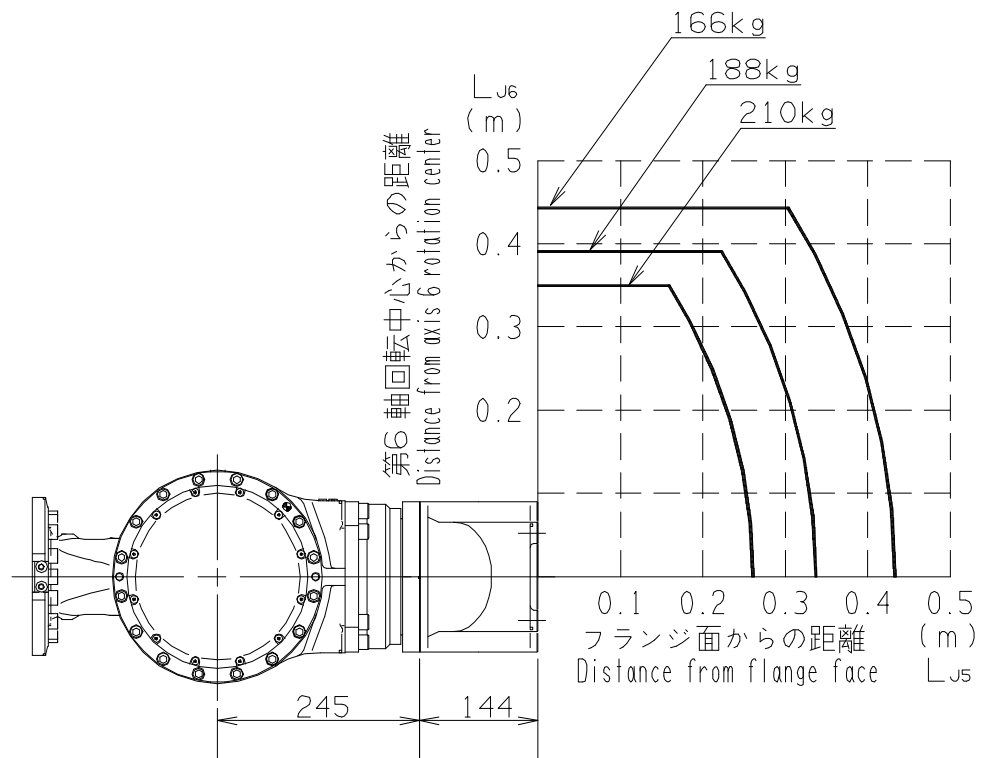

【SRA240-01】

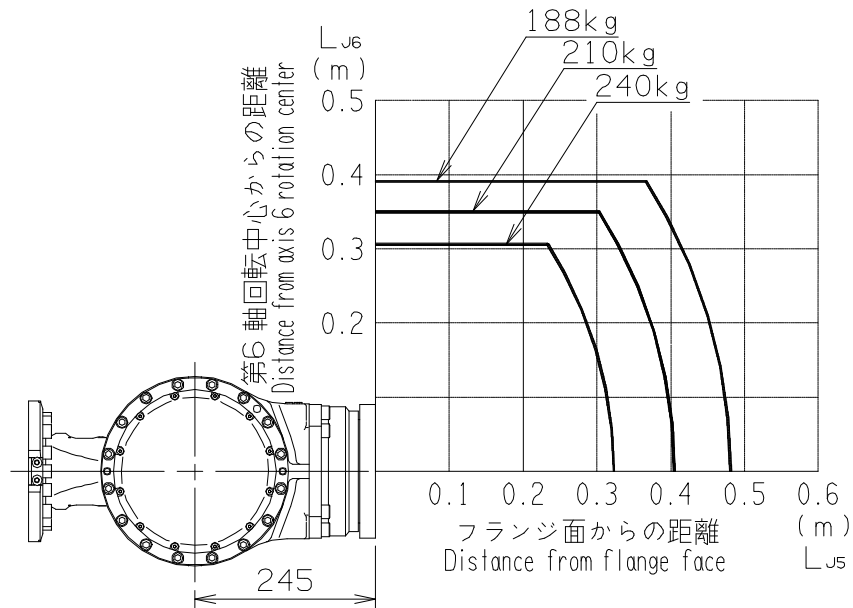

【SRA250-01】



【SRA120EL-01】

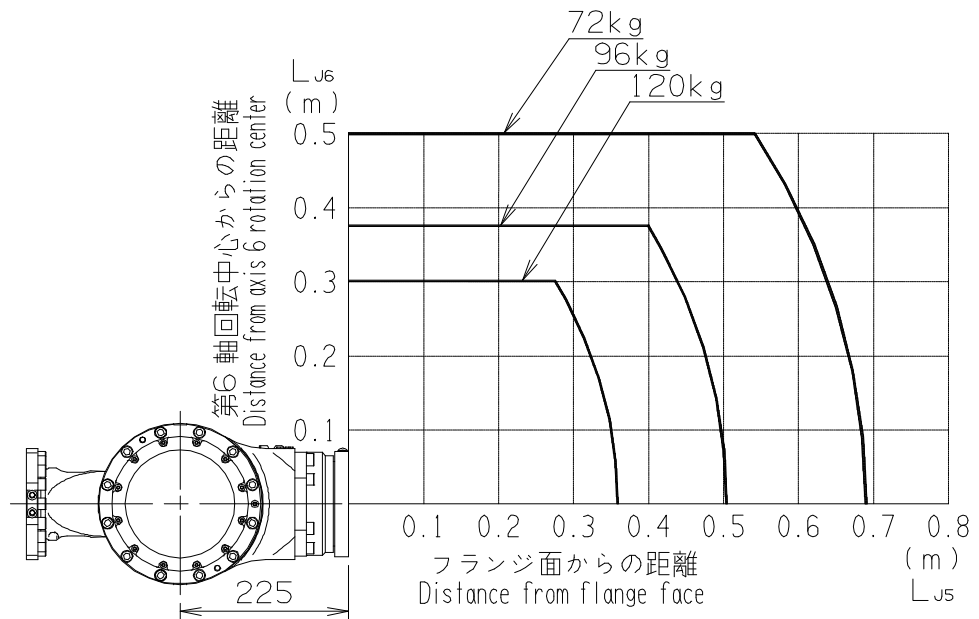

【SRA133L-01】

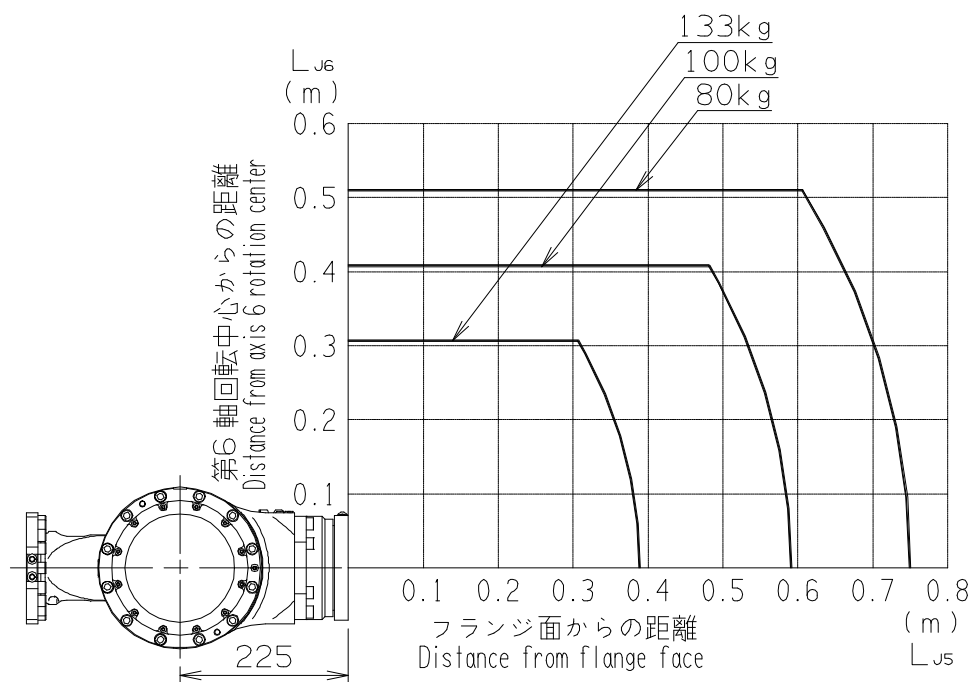

■ Wrist load conditions

Static load torque and moment of inertia of wrist load should exist inside the range shown below.

 IMPORTANT	If the real inertia is over the limit written in "2. Basic specifications", maximum speed will be restrained by software.
---	---

【SRA100-01】
【SRA100-01A】

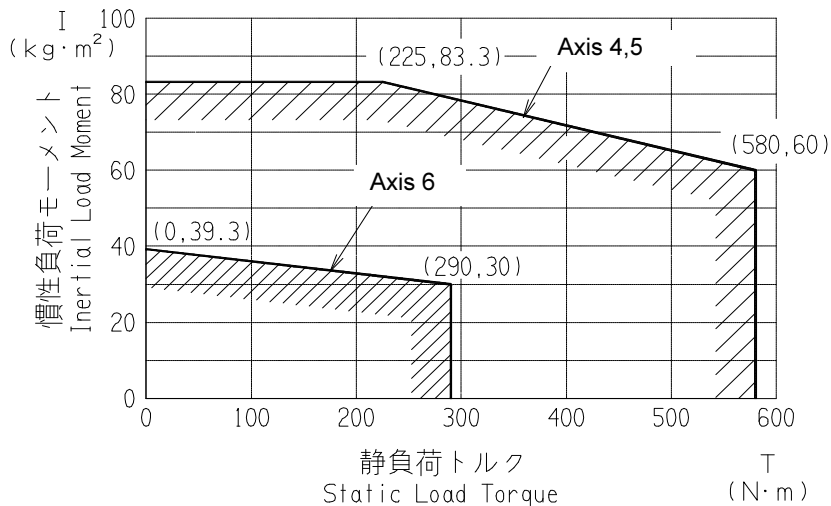

【SRA166-01】
【SRA166-01A】
【SRA166L-01】

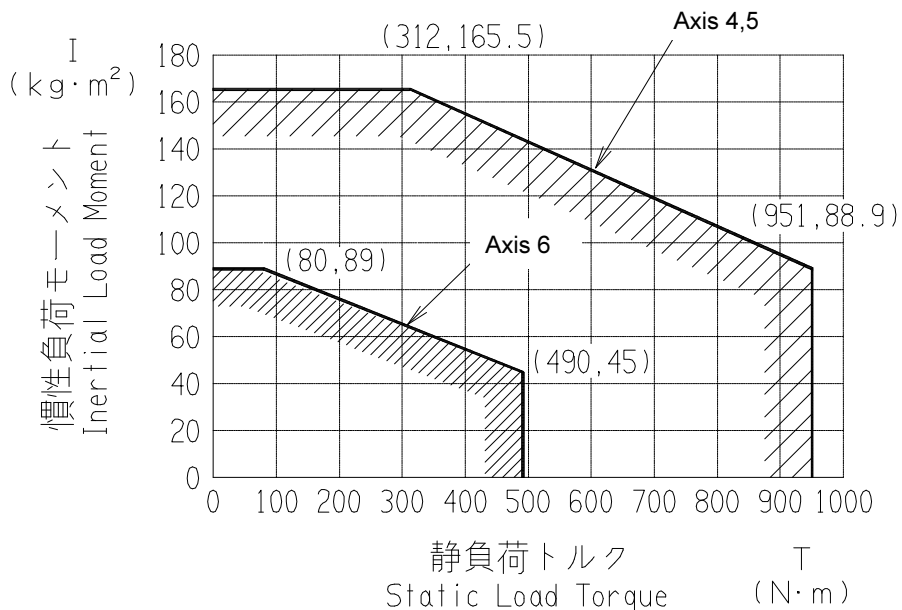

【SRA210-01】
 【SRA240-01】
 【SRA210-01A】

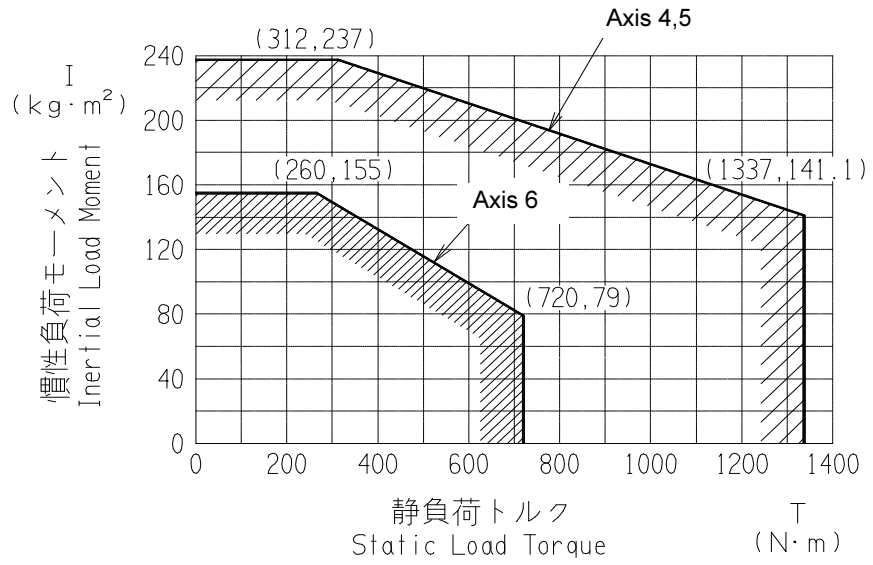

【SRA250-01】

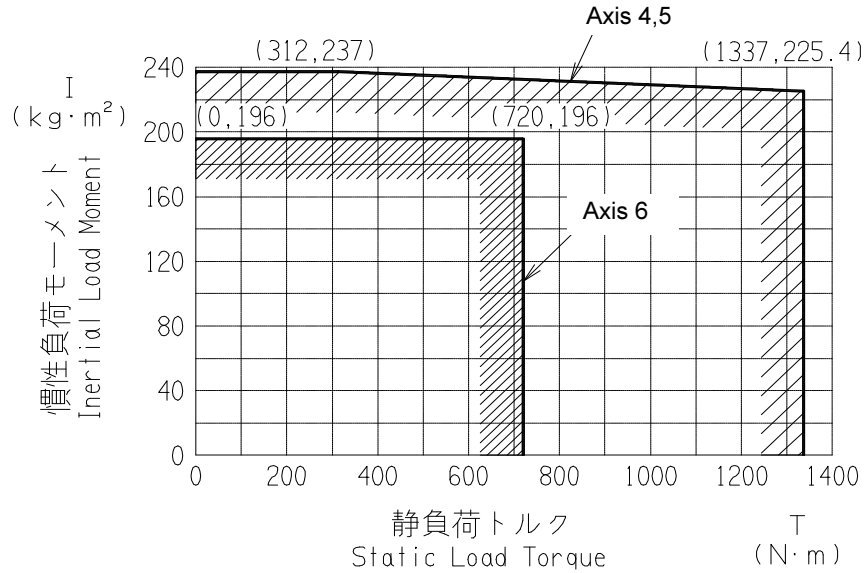

Robot speed is adequately controlled according to the inertia.

【SRA120EL-01】

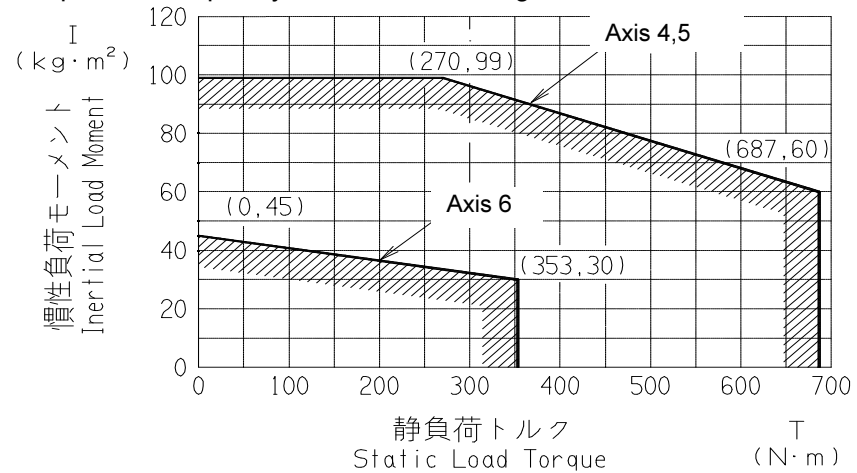

【SRA133L-01】

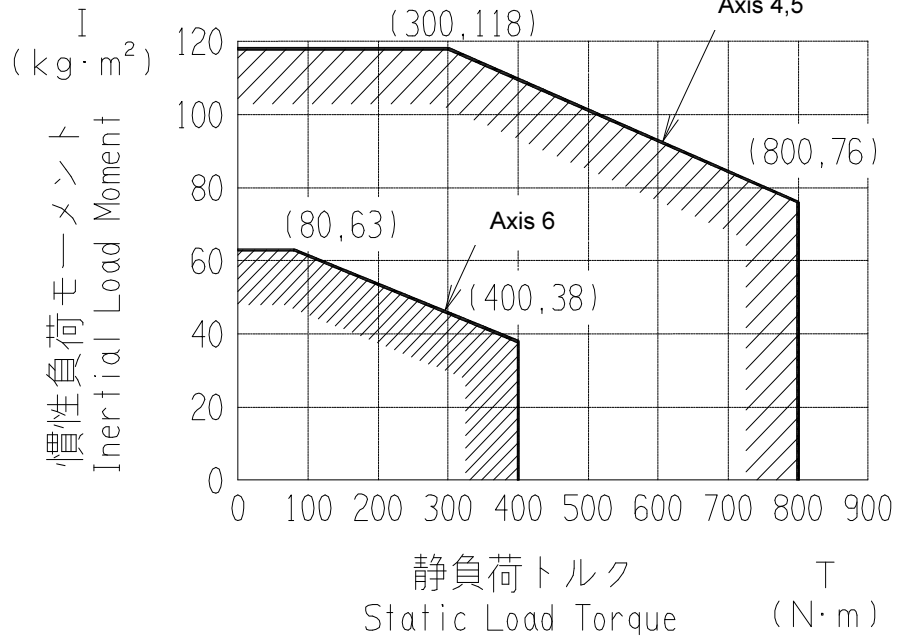

■ How to find the inertia moment

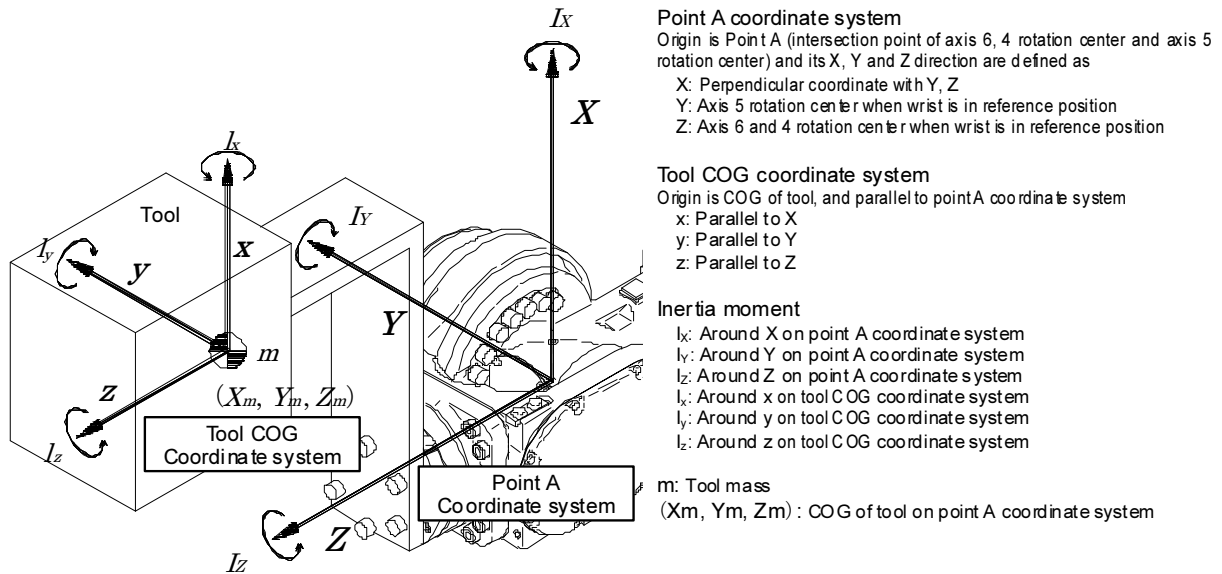

<p>1 Calculate inertia moment defined on tool COG coordinate system (xyz). If tool is regarded as prism, it is calculated as right formula.</p>	<p>Inertia moment example on tool COG coordinate system</p> <p>If tool is regarded as prism</p> $I_x = \frac{1}{12} m \cdot (A^2 + B^2)$ $I_y = \frac{1}{12} m \cdot (A^2 + C^2)$ $I_z = \frac{1}{12} m \cdot (B^2 + C^2)$ <p>These values (I_x, I_y, I_z) are registered to controller.</p> <p>Inertia moment on tool COG coordinate system</p> <p>This is different from "allowable moment of inertia" written in robot specification sheet.</p>
<p>2 Calculate inertia moment defined on point A coordinate system (XYZ), then calculate inertia moment around robot wrist joint (axis 4, 5 and 6). This result must not be larger than "Allowable moment of inertia" written in robot specification sheet.</p>	<p>Inertia moment on point A coordinate system (XYZ) is</p> $I_X = m \cdot (Y_m^2 + Z_m^2) + I_x$ $I_Y = m \cdot (X_m^2 + Z_m^2) + I_y$ $I_Z = m \cdot (X_m^2 + Y_m^2) + I_z$ <p>Axis 4 and 5 inertia moment is larger value of I_x and I_y, because this depends on axis 6 position. Axis 6 inertia moment is I_z itself.</p> $I_{J4} = I_{J5} = \max(I_X, I_Y)$ $I_{J6} = I_Z$

■ Allowable forearm load

Use the robot under condition that COG of the ancillary equipment on the forearm falls in the range shown below.

[SRA100-01]
When wrist load is 100kg

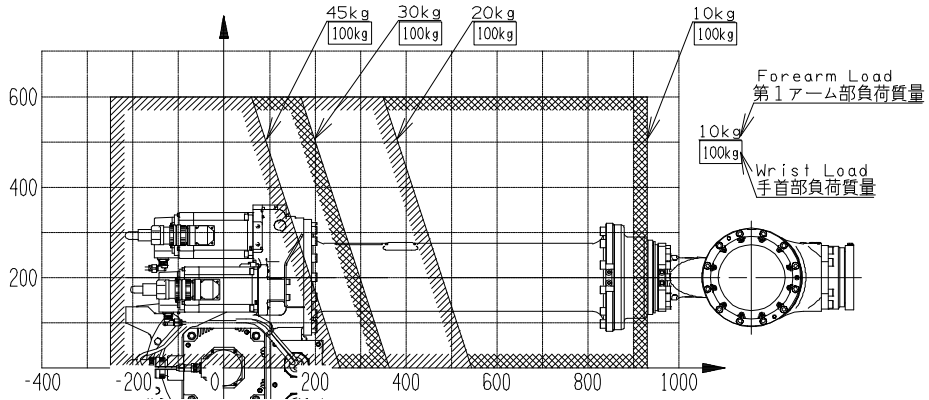

[SRA100-01A]
When wrist load is 100kg or 80Kg

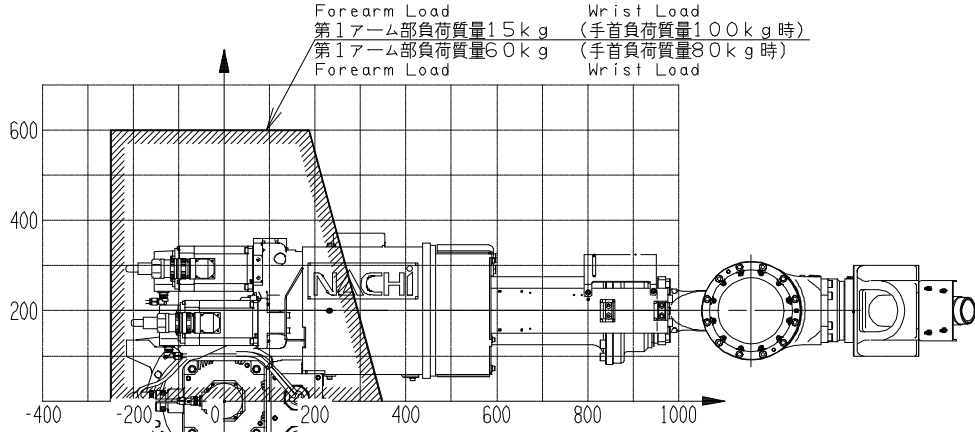

[SRA166-01]
When wrist load is 166kg

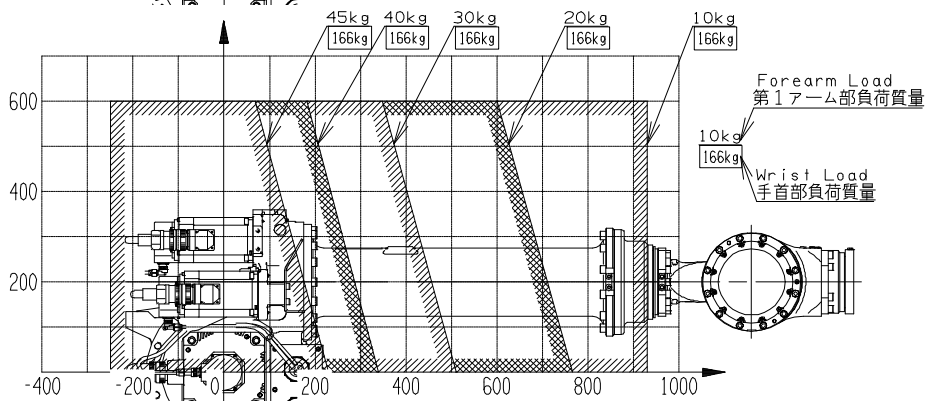

[SRA166-01A]
When wrist load is 166kg or 145Kg

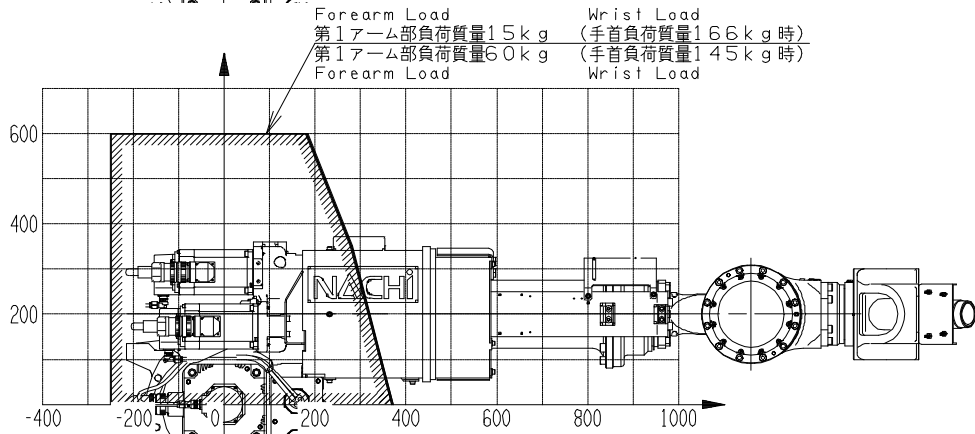

[SRA210-01]
When wrist load is 210kg

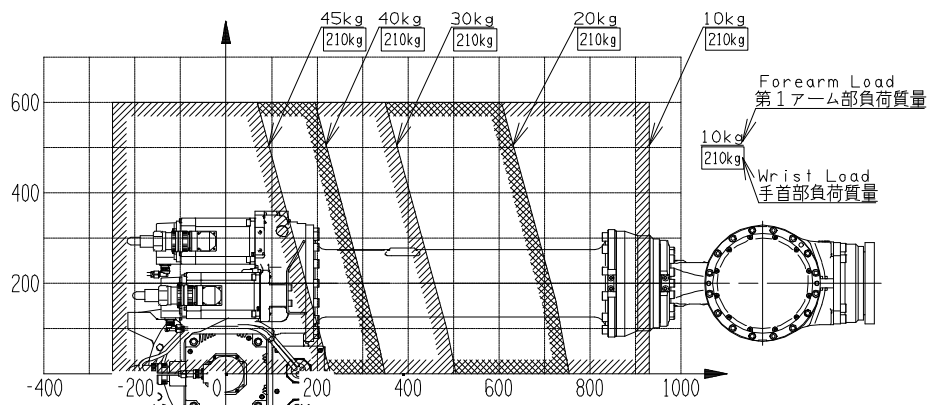

[SRA210-01A]
When wrist load is 210kg or 180kg

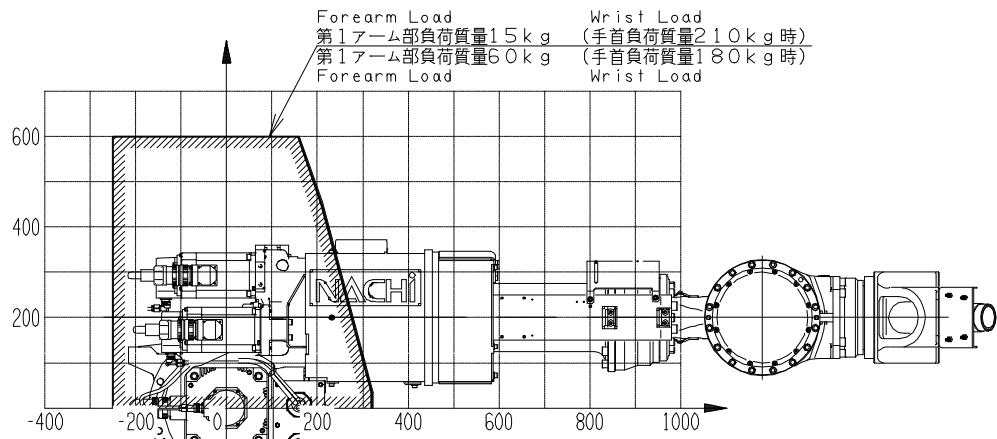

[SRA240-01]
When wrist load is 240kg

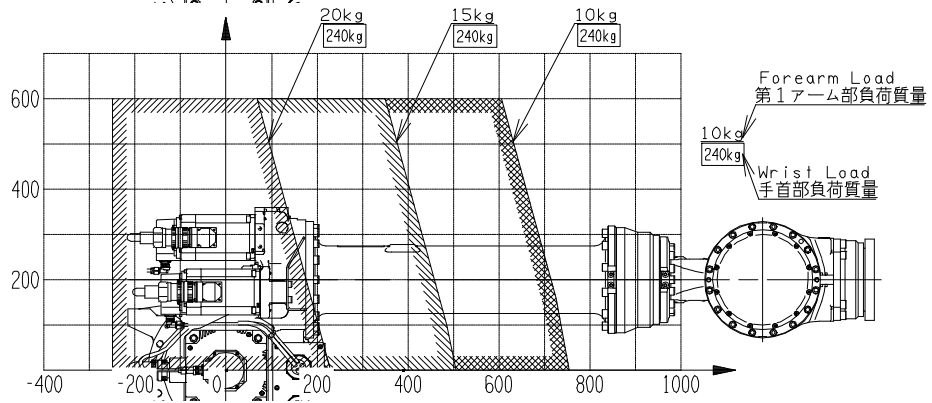

[SRA250-01]
When wrist load is 250kg

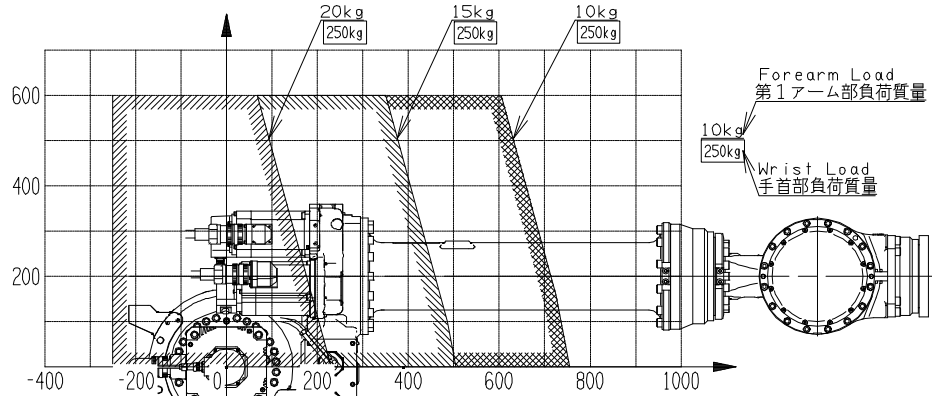

[SRA120EL-01]
When wrist load is 120kg

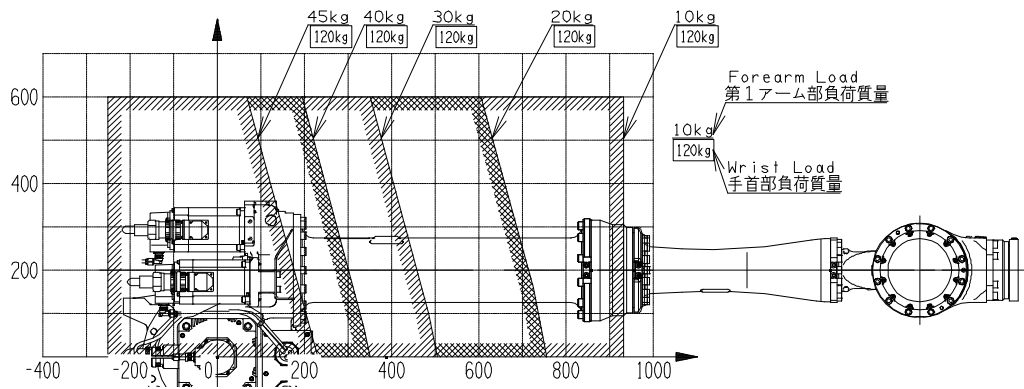

[SRA166L-01]
When wrist load is 166kg

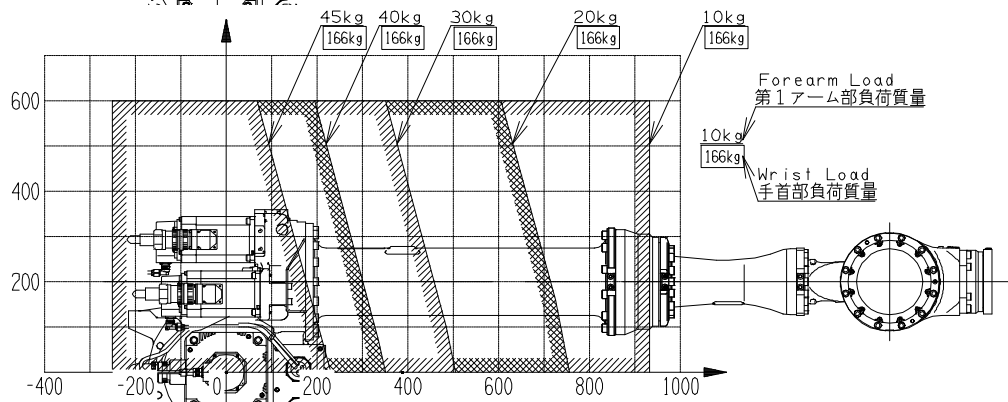

[SRA133L-01]
When wrist load is 133kg

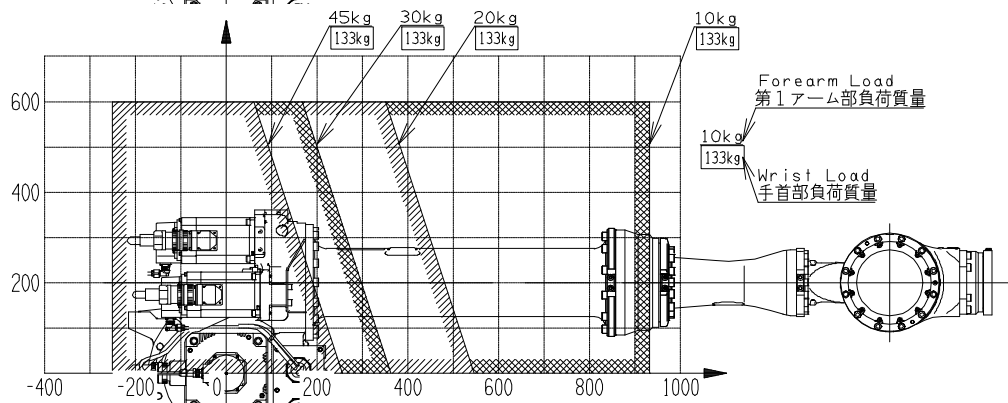

7. Option specifications

○: Possible to correspond / -: Impossible to correspond

No.	Item	Specifications	Parts No.	Robot model												
				SRA100-01	SRA166-01	SRA210-01	SRA240-01	SRA250-01	SRA100-01A	SRA166-01A	SRA210-01A	SRA120EL-01	SRA133L-01	SRA166L-01		
1	Installation parts *1	Chemical anchor specification with pin hole	OP-F1-024	○	○	○	○	○	○	○	○	○	○	○	○	
		Base plate welded (anchors not included) without pin hole	OP-F1-028	○	○	○	○	○	○	○	○	○	○	○	○	
		Hammer drive anchor specification with pin hole	OP-F2-018	○	○	○	○	○	○	○	○	○	○	○	○	
		Base plate welded (anchors not included) without pin hole	OP-F2-019	○	○	○	○	○	○	○	○	○	○	○	○	
		Pins set (Installation pins & polyethylene plug)	OP-F1-025	○	○	○	○	○	○	○	○	○	○	○	○	
		Leveling plate (□200mm×t=32mm, 4 plates)	OP-F1-026	○	○	○	○	○	○	○	○	○	○	○	○	
		Installation bolts & washers	OP-F1-027	○	○	○	○	○	○	○	○	○	○	○	○	
		Chemical anchor	OP-F1-038	○	○	○	○	○	○	○	○	○	○	○	○	
	Hammer drive anchor	OP-F2-023	○	○	○	○	○	○	○	○	○	○	○	○		
2	Motion range LS			Refer to the "Motion range limit option" table on the next page												
3	Adjustable LS dog															
4	Adjustable stopper															
5	Big capacity application box	Big capacity BJ3 wiring junction box	OP-E5-003	○	○	○	○	○	○	○	○	○	○	○	○	
6	Transfer jig	Fork bracket for floor mounting type	OP-S2-033	○	○	○	○	○	○	○	○	○	○	○	○	
7	Zeroing pin & Zeroing block *1	For 166 kg payload (for 100-166 kg)	OP-T2-053	○	○	-	○	○	○	-	○	○	○	○	○	
		For 210 kg payload (for 210-250 kg)	OP-T2-054	-	-	○	○	○	-	-	-	-	-	-	-	
8	ISO Flange adaptor	Converts into the tool installation size with ISO	OP-W2-001	○	○	-	-	-	-	-	-	○	○	○	○	
9	Flange adaptor	For 166 kg payload (for 100-166 kg) (P.C.D.92)	OP-W3-001	○	○	-	-	-	-	-	-	○	○	○	○	
		For 210 kg payload (for 210-250 kg) (P.C.D.92, 125)	OP-W3-006	-	-	○	○	○	-	-	-	-	-	-	-	
10	Wrist axis positioning marking *3	For 166 kg payload (for 100-166 kg)	OP-N3-006	○	○	-	-	-	-	-	-	○	○	○	○	
		For 210 kg payload (for 210-250 kg)	OP-N3-007	-	-	○	○	○	-	-	-	-	-	-	-	
11	Encoder connector Protector	For axis 3	OP-P6-005	○	○	○	○	○	○	○	○	○	○	○	○	
12	Bypass cable *1		BCUNIT20-30	○	○	○	○	○	○	○	○	○	○	○	○	
13	Arm fixed jig *1	For axis 2	KP-ZD-005	○	○	○	○	○	○	○	○	○	○	○	○	
		For axis 3 (for 100-240kg)	KP-ZJ-011	○	○	○	○	-	○	○	○	○	○	○	○	
		For axis 3 (for 250kg)	KP-ZJ-045	-	-	-	-	○	-	-	-	-	-	-	-	
14	Scale seal *3	For wrist three axes	OP-N2-020	○	○	○	○	○	○	○	○	○	○	○	○	
15	Gas balancer unit Pressure gauge *1	Analog pressure gauge	KP-ZJ-013	○	○	○	○	○	○	○	○	○	○	○	○	
		Digital pressure gauge	KP-ZJ-014	○	○	○	○	○	○	○	○	○	○	○	○	○
16	Gas balancer unit Charging equipment *1 *2	Charging unit (W22, pitch14, Female)	KP-ZJ-015	○	○	○	○	○	○	○	○	○	○	○	○	
		Charging unit (W23, pitch14, Male)	KP-ZJ-016	○	○	○	○	○	○	○	○	○	○	○	○	
		Joint of Female->Male (W22)	KP-ZJ-019	○	○	○	○	○	○	○	○	○	○	○	○	○
		Analog pressure gauge	KP-ZJ-013	○	○	○	○	○	○	○	○	○	○	○	○	○

*1 : These parts are packed separately from the robot. (Not attached on the robot)

*2 : If diameter of charging equipment is "W22, pitch14, Female, Right screw, Metal contacts", please prepare the charging equipment "KP-ZJ-015" and the joint "KP-ZJ-019".

*3 : "Wrist axis positioning marking" and "Scale seal" can not be used at the same time. Please select either one.

■ Motion range limit option

Option	Specification
Motion range LS	Motion range limit switch (dual circuit) and dog can be installed for axis 1, 2 and 3. This option includes limit switches of axis 1, 2 and 3. This option is already mounted before shipment..
Adjustable LS dog	Motion range can be limited by installing Limit switch dog at various angles. This can be selected for axis 1, 2 and 3 individually. This option is only changing the dog position. Limit Switch itself is not included. Please order "Motion range LS" option at the same time. This option is shipped separately. (Not mounted on robot before shipment).
Adjustable stopper	Motion range can be limited by installing a mechanical stopper at various angles. This can be selected for axis 1, 2 and 3 individually. This is a separate option from "Motion range LS". In case that "Motion range LS" option is used together, "Adjustable LS dog" option must be ordered at the same time, because LS dog position needs to be adjusted. This option is shipped separately. (Not mounted on robot before shipment). Axis 1 is adjustable from: ± 2.61 rad \sim ± 0 rad, every 0.17 rad Axis 2 is adjustable from: -0.26 and -0.52 rad, from the operation edge Axis 3 is adjustable from: -0.52, -0.79, -1.05, -1.31 and -1.57 rad from the operation edge

Motion range limit option for 100~240kg payload class robot

	Parts No.		
	Axis 1	Axis 2	Axis 3
Motion range LS	OP-D7-008 (3 pcs. set)		
Adjustable LS dog	OP-S5-019	OP-S8-007	OP-S4-009
Adjustable stopper		OP-A5-027	OP-A6-023

Motion range limit option for 250kg payload class robot

	Parts No.		
	Axis 1	Axis 2	Axis 3
Motion range LS	OP-D7-017 (3 pcs. set)		
Adjustable LS dog	OP-S5-019	OP-S8-007	OP-S4-014
Adjustable stopper		OP-A5-027	OP-A6-029

<Notes> ·Only for axis 1, "Adjustable stopper" includes "Adjustable LS dog". Please note that even if only the stopper is used, that the LS dog is already included as a package.

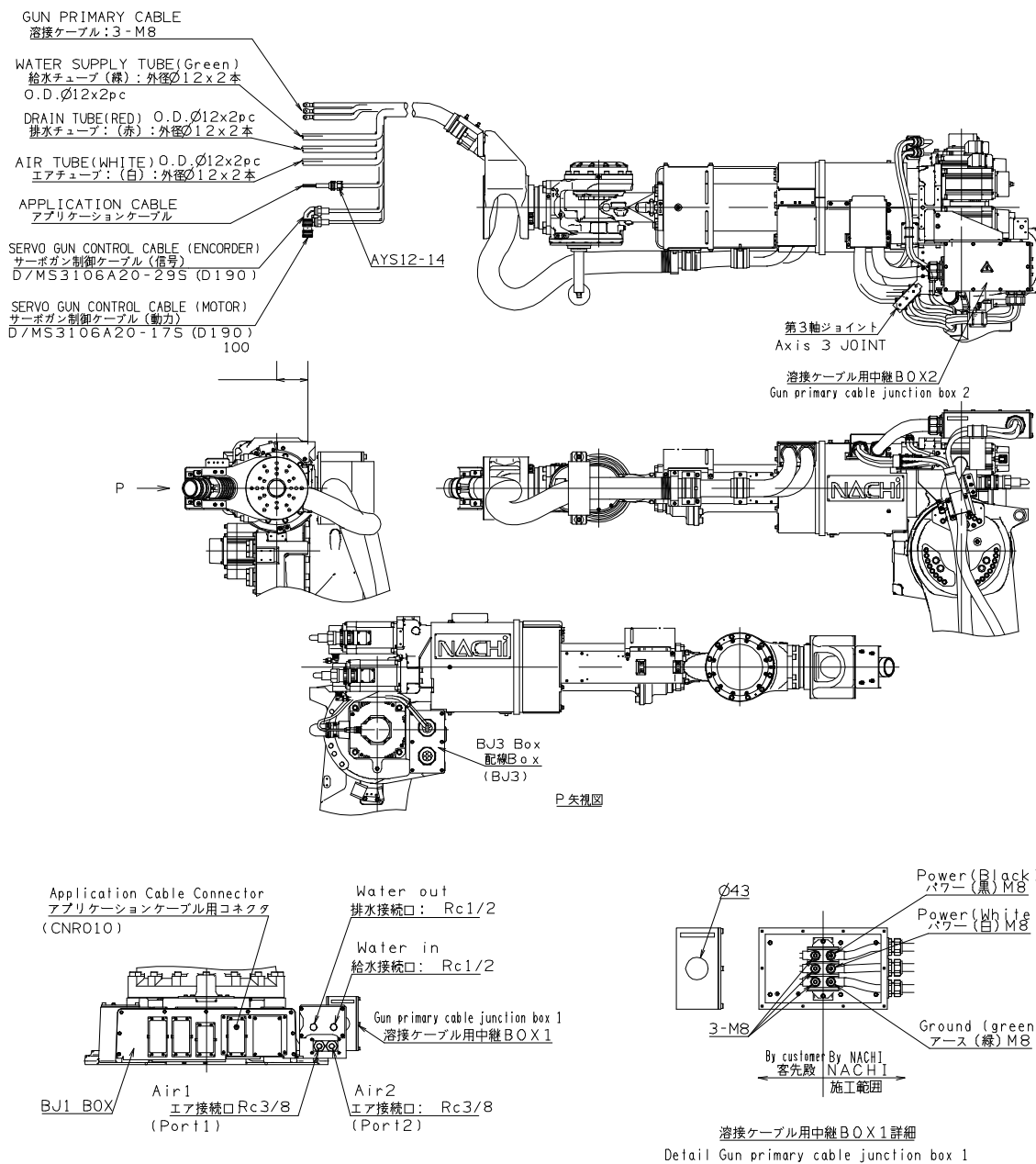

※ In wiring BOX (BJ3 BOX), there is an “application connector of BJ3 side”.

■ Standard specification

【SRA100-01】【SRA166-01】【SRA210-01】【SRA240-01】【SRA250-01】
 【SRA120EL-01】【SRA133L-01】【SRA166L-01】

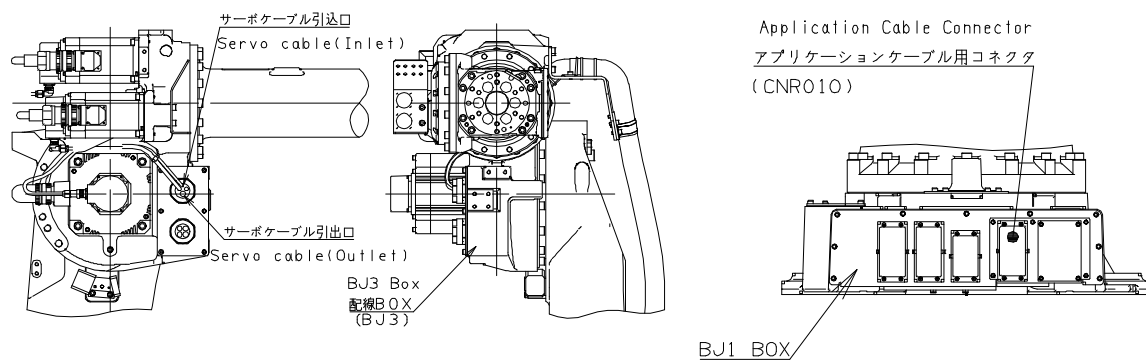
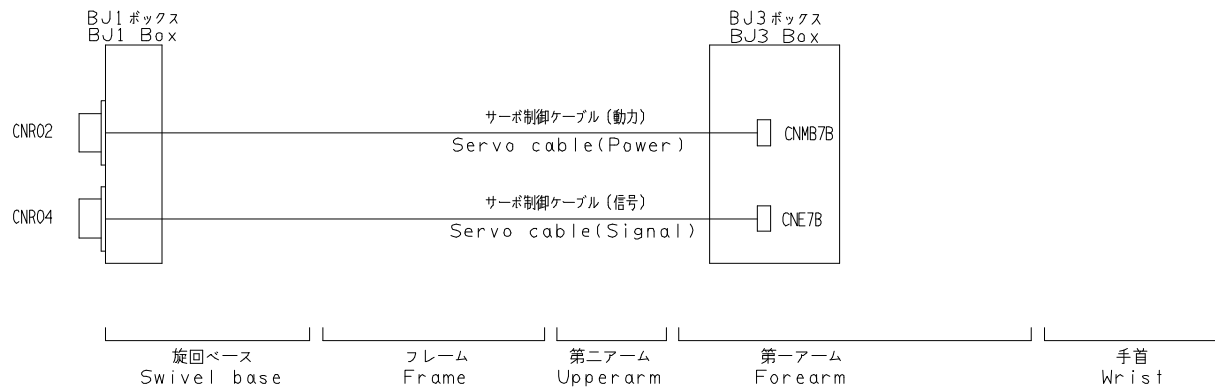

※ In wiring BOX (BJ3 BOX), there is an “application connector of BJ3 side”.

■ Detailed diagram of the application connectors

【SRA100-01A】【SRA166-01A】【SRA210-01A】

(These are option for 【SRA100-01】【SRA166-01】【SRA210-01】【SRA240-01】【SRA250-01】【SRA120EL-01】【SRA133L-01】【SRA166L-01】)

(1) BJ1 side (connector)

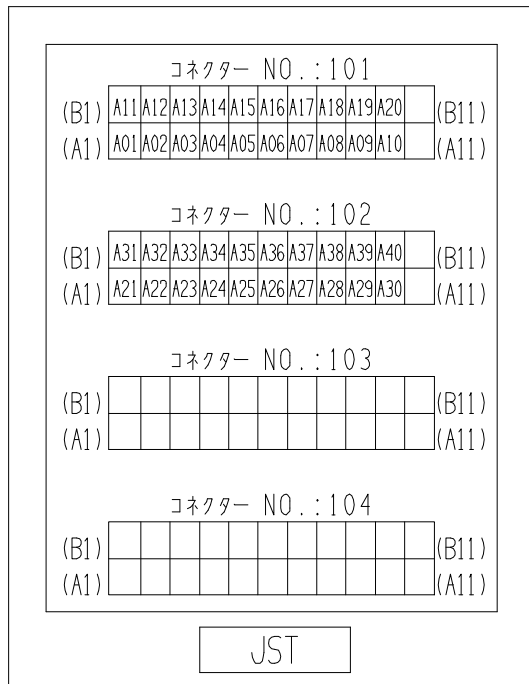

User-side Connectors

Wire-side shell: JFM-WSA-4-A (JST)
or JFM-WSA-4-C (JST)

Guide plate A kit: JFM-GPAK-4 (JST)

Receptacle housing: JFM2FDN-22V-K (JST)

Receptacle contact:

a: SJ2F-01GF-P1.0 (JST) (0.20 ~ 0.50sq)

b: SJ2F-21GF-P1.0 (JST) (0.30 ~ 0.75sq)

Manual crimp tool:

a: YRS-8861

b: YRF-1120

Cable diameter suitable for wire-side shell:

JFM-WSA-4-A φ26.2~φ28.0

JFM-WSA-4-C φ15.5~φ16.5

(Pin location shows the connector mounted on robot body and is the view from connecting side.)

Application wiring specification

Rated voltage Max. AC/DC 115 V

Rated current rating Max. 1 A

(2) BJ3 side (connector)

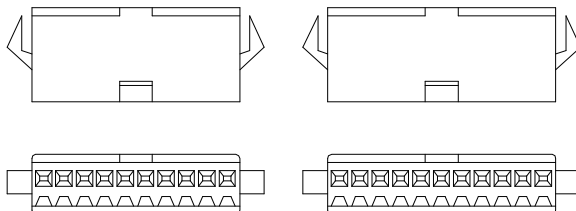

CN61

1	2	3	4	5	6	7	8	9	10
A01	A02	A03	A04	A05	A06	A07	A08	A09	A10

CN62

1	2	3	4	5	6	7	8	9	10	11
A11	A12	A13	A14	A15	A16	A17	A18	A19	A20	E

CN63

1	2	3	4	5	6	7	8	9	10
A21	A22	A23	A24	A25	A26	A27	A28	A29	A30

CN64

1	2	3	4	5	6	7	8	9	10	11
A31	A32	A33	A34	A35	A36	A37	A38	A39	A40	E

Connector form (CN61, CN63)

Housing SMP-10V-BC (JST)

User-side Connectors

Housing SMR-10V-B (JST)

Contact SYM-001T-P0.6 (Wire of Application : AWG#22~28)

Pressure tool YRS-121

Connector form (CN62, CN64)

Housing SMP-11V-BC (JST)

User-side Connectors

Housing SMR-11V-B (JST)

Contact SYM-001T-P0.6 (Wire of Application : AWG#22~28)





Pressure tool YRS-121

※ In spot specification, CN61 and CN62 are connected directly with the wrist flange as an application cable. Connectors are not attached.

9. Transport procedure

Safety measures against transport

The following describes precautions for transporting the robot. Fully understand the precautions for safe transport work.

 WARNING	The robot must be transported by personnel who have licenses required for slinging work, crane operation, forklift truck operation, and others. The weight of the robot and controller is listed in the Operating Manual and the Maintenance Manual. Check for the weight, and then handle them according to procedures suitable for the weight.
 WARNING	To lift the robot or the controller, follow the procedures specified in the Maintenance Manual. Following any procedures other than those specified will cause the robot to topple over or drop during transport, thus resulting in accidents.
 WARNING	During transport or installation work of the robot, pay utmost care not to cause damage to wirings. Furthermore, after installing the robot, take protective measures such as using protective guards so that the wirings will not be damaged by workers or other persons, or forklift trucks or else.
 WARNING	Gas in balancer must be released when robot is transported by air. Gas in balancer must be charged before using robot, so customer needs to prepare the nitrogen gas and charging unit. Please contact to NACHI-FUJIKOSHI office to order the charging unit. Charging procedure is written in manipulator maintenance manual.

To transport the robot, make it a rule to use a crane.

At first, put the robot into the configuration shown in figure below and mount the four M20 hanger bolts to the swivel base. Then, be sure to lift the robot using four hanging wires. For this purpose, it is recommended to use hanging wires of 3 m in length and protect areas that contact the robot, using rubber hoses to cover the wire ropes. For the areas to be covered with the rubber hoses refer to figure below.

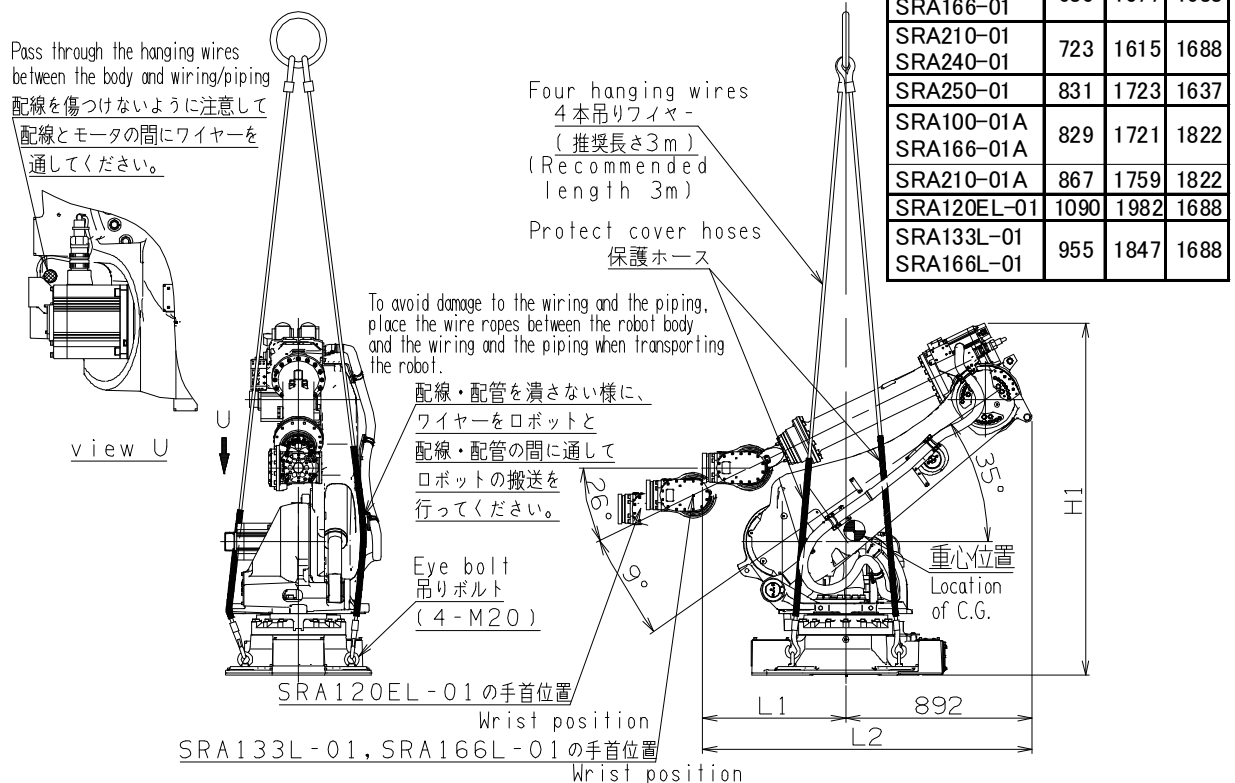

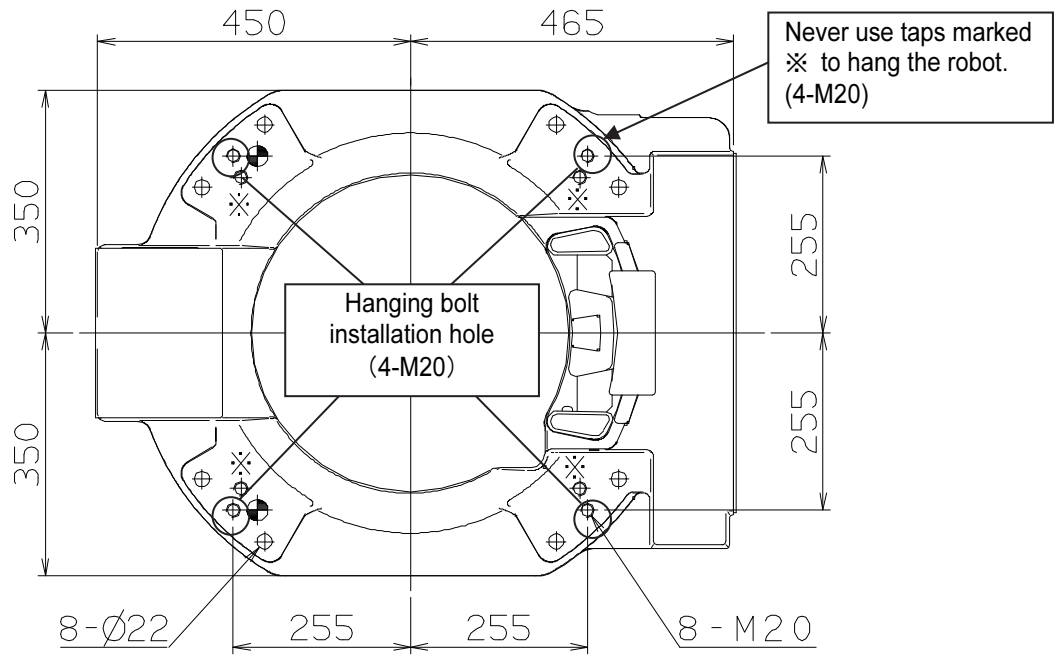

The screw hole of the ※ sign is not used for the hanging bolt.



If hanging wires push the encoder connectors or wiring/piping, they may be broken when hanging the robot. When hanging the robot, please pay attention not to make the wires touch the encoder connectors and wiring/piping.

To avoid damage to the wiring and the piping, place the wire ropes between the robot body and the wiring and the piping when transporting the robot.

配線・配管を潰さない様に、ワイヤーをロボットと配線・配管の間に通してロボットの搬送を行って下さい。

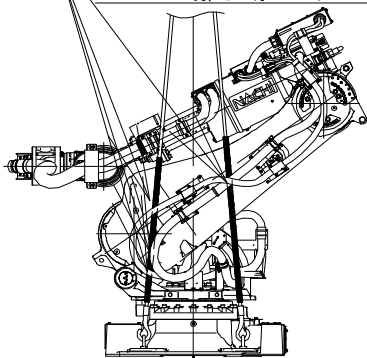

Axis 3 Encoder Connector
第3軸エンコーダコネクタ
Axis 6 Encoder Connector
第6軸エンコーダコネクタ

Axis 5 Encoder Connector
第5軸エンコーダコネクタ
Axis 4 Encoder Connector
第4軸エンコーダコネクタ

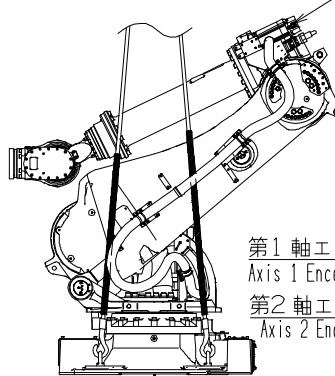

第1軸エンコーダコネクタ
Axis 1 Encoder Connector
第2軸エンコーダコネクタ
Axis 2 Encoder Connector

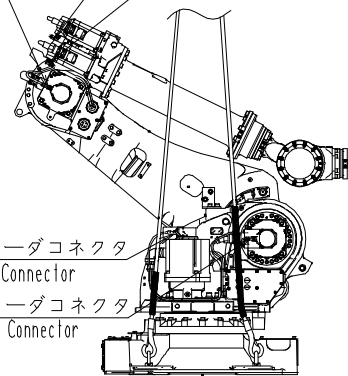

10. Delivery style (specification which contains a robot)

1. There are three styles as shown below.

	Style	Details
1	Delivery on the truck	Robot is delivered on the truck near the entrance of customer's plant. (Installation and test-run is not included)
2	Delivery after installation and test-run	Robot is installed and test-run is done. (Teaching with work piece is not included.)
3	Delivery after installation and teaching with work piece	After style 2, teaching with work piece is done.

Because the expense is different, which form to choose be sufficiently examined.

Gas in balancer is not filled when robot is transported by air. Gas in balancer must be charged before using robot, so customer needs to prepare the nitrogen gas and charging unit. Please contact to NACHI-FUJIKOSHI office to order the charging unit. Charging procedure is written in manipulator maintenance manual.

2. Operation and maintenance education

The special spot operation guide and the special spot preservation guide are the outside of the estimation. Consult with each NACHI-FUJIKOSHI office for the details as for the schooling system.

11. Consuming power (Robot + Controller)

7.0 kVA (may vary according to the application and motion pattern.)

12. Paint color

Standard color	Controller cabinet	Munsell 10GY9/1
	Robot body	Munsell 10GY9/1

13. Warranty

Elapse of 1 year after delivery. (8 hours/day running)

The specification and externals described in this specifications might change without a previous notice for the improvement.

NACHI NACHI-FUJIKOSHI CORP.		http://www.nachi-fujikoshi.co.jp/	
Japan Main Office	Phone: +81-3-5568-5245	Fax: +81-3-5568-5236	Shiodome Sumitomo Bldg. 17F, 1-9-2 Higashi-Shinbashi Minato-ku, TOKYO, 105-0021 JAPAN
Nachi Robotic Systems Inc. (NRS)		http://www.nachirobotics.com/	
North America Headquarters	Phone: 248-305-6545	Fax: 248-305-6542	46200 W.12 Mile Rd. Novi, Michigan 48377, U.S.A.
Indiana Service Center	Phone: 248-305-6545	Fax: 248-305-6542	Greenwood, Indiana
Ohio Service Center	Phone: 248-305-6545	Fax: 248-305-6542	Cincinnati, Ohio
South Carolina Service Center	Phone: 248-305-6545	Fax: 248-305-6542	Greenville, South Carolina
Canada Branch Office	Phone: 905-760-9542	Fax: 905-760-9477	89 Courtland Ave., Unit No.2, Concord, Ontario, L4K 3T4, CANADA
Mexico Branch Office	Phone :+52-555312-6556	Fax:+52-55-5312-7248	Av. 100 Metros 1112-A, N. Industrial Vallejo, Gustavo A. Madero, CDMX, 07700, MEXICO
NACHI EUROPE GmbH		http://www.nachi.de/	
Central Office Germany	Phone: +49-2151-65046-0	Fax: +49-2151-65046-90	Bischofstrasse 99, 47809, Krefeld, GERMANY
U.K. branch	Phone: +44-0121-423-5000	Fax: +44-0121-421-7520	Unit 3, 92, Kettles Wood Drive, Woodgate Business Park, Birmingham B32 3DB, U.K.
Czech branch	Phone: + 420-255-734-000	Fax: +420-255-734-001	Obchodni 132, 251 01 Cestice, PRAGUE-EAST CZECH REPUBLIC
Turkey branch	Phone: + 90-(0)216-688-4457	Fax: +90-(0)216-688-4458	Ataturk Mah. Mustafa Kemal Cad. No:10/1A 34758 Atasehir / Istanbul - TURKEY
NACHI AUSTRALIA PTY. LTD.		http://www.nachi.com.au/	
Robotic Division & Victoria office	Phone: +61-(0)3-9796-4144	Fax: +61-(0)3-9796-3899	38, Melverton Drive, Hallam, Victoria 3803, , AUSTRALIA
Sydney office	Phone: +61-(0)2-9898-1511	Fax: +61-(0)2-9898-1678	Unit 1, 23-29 South Street, Rydalmere, N.S.W, 2116, AUSTRALIA
Brisbane office	Phone: +61-(0)7-3272-4714	Fax: +61-(0)7-3272-5324	7/96 Gardens Dr,Willawong,QLD 4110, , AUSTRALIA
NACHI SHANGHAI CO., LTD.		http://www.nachi.com.cn/	
Shanghai office	Phone: +86-(0)21-6915-2200	Fax: +86-(0)21-6915-2200	11F Royal Wealth Centre, No.7 Lane 98 Danba Road Putuo District, Shanghai 200062, China
NACHI KOREA		http://www.nachi-korea.co.kr/	
Seoul office	Phone: +82-(0)2-469-2254	Fax: +82-(0)2-469-2264	2F Dongsan Bldg. 276-4, Sungsu 2GA-3DONG, Sungdong-ku, Seoul 133-123, KOREA

Copyright NACHI-FUJIKOSHI CORP.

Robot Division

1-1-1, FUJIKOSHIHONMACHI, TOYAMA CITY, JAPAN 930-8511

Phone +81-76-423-5137

Fax +81-76-493-5252

NACHI-FUJIKOSHI CORP. holds all rights of this document. No part of this manual may be photocopied or reproduced in any form without prior written consent from NACHI-FUJIKOSHI CORP. Contents of this document may be modified without notice. Any missing page or erratic pagination in this document will be replaced.

In case that an end user uses this product for military purpose or production of weapon, this product may be liable for the subject of export restriction stipulated in the Foreign Exchange and Foreign Trade Control Law. Please go through careful investigation and necessary formalities for export.

Original manual is written in Japanese.

NACHI-FUJIKOSHI CORP. ©