

# Pallet Leveller - Spring Activated / Galvanised

Galvanised Pallet Levellers have a top deck and a base connected by a pair of scissor legs. The levelling mechanism is a set of springs set to the weight and height (the density) of the product. Pallet levellers work automatically and raise or lower as the weight changes. Load setting is a simple process and for most users springs never have to be changed.

## Features

- Easy to move with a forklift.
- A shock absorber prevents any bounce.
- Hot galvanized finish to help prevent rust and corrosion.
- Dramatically reduces the effort required to palletise goods.
- Built-in turntable allows simple load rotation and access to all sides.
- Comes with 3 springs, the springs are chosen to match the weight and height of a fully load pallet.
- Automatically keeps pallet or stillage loads at an optimum working height when loading or unloading goods.
- Durable and tough, this pallet leveller can be used in a wide range of applications including warehousing, wash down and other harsh environments.

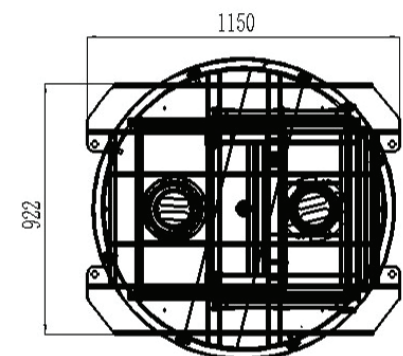
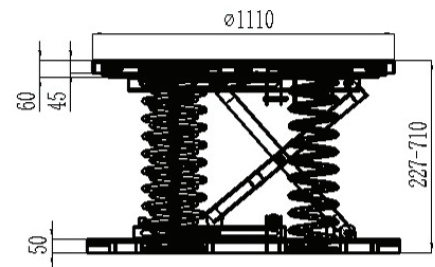

## Specifications

Model		SPP360-2000G
Capacity	(kg)	2000
Min Table Height	(mm)	240
Max Table Height	(mm)	710
Base Size	(mm)	L1150xW922
Platform Diameter	(mm)	1110
Fork Pocket Dimensions WxH	(mm)	168x50
Net Weight	(kg)	128

Visit [www.mitaco.com.au](http://www.mitaco.com.au) for more photos and details

Mitaco has national sales and distribution capabilities, our sales office and warehouse is located in Brisbane. Large inventory holdings enable fast-track dispatch of stock orders. This combined with an easy to use online ordering system makes the delivery of stocked products simple, fast and reliable.