



# FABRIC EXPANSION JOINTS

Providing Specialised Expansion Joint Technology



T +49 6182 21014

E [info@dekomte.com](mailto:info@dekomte.com)

W [www.dekomte.com](http://www.dekomte.com)

---

# Our Company

DEKOMTE de Temple offer innovative and quality expansion joint solutions to bring reliability of operation in the applications they are installed, whilst creating better technologies that benefit both the customer and the environment.

As a specialist engineering company, we can offer complete product management, starting from the initial design to the maintenance of the expansion joint. It is the extensive experience and technical nature of DEKOMTE that has led to the successful application of expansion joints in a wide array of industries.

Typical applications are industrial incinerators and annealing furnaces, power plants, steel plants, petrochemical installations, pyrolysis and precipitators, HVAC, food industry and also the fire-proofing of wall penetrations.

DEKOMTE considers the expansion joint to be an integral part of the duct system. Only through proper evaluation and integration of all the components, such as the duct connection, duct material and the steel frame design, can an optimised solution regarding technology and price be achieved.

Engineering support in the form of annual inspections or life time assessments can form a critical part of the maintenance planning of a power plant or industrial manufacturing process. DEKOMTE can support and advise its customers on supply and installation appropriate to their requirements. The design of the expansion joint uses the latest materials and composition to optimise cost and technical function.

Post-installation, our competent customer service team is always available to help you; either by answering queries or the rapid, problem-free complete product replacement.

## Fabric Expansion Joints

Fabric expansion joints are suited for gaseous media, such as air, exhaust gases and solvent fumes, as well as for operation below dew point (also involving substances with certain concentration of acids), also with abrasive enriched gases (e.g. coal or cement dust).

Due to their modular design, fabric expansion joints adjust especially well to different requirements (e.g. critical sealing requirements, frequent temperature and pressure variations), and therefore, cover a very wide spectrum of applications.

The high quality materials as well as the technical experience in designing and manufacturing assure the long life and durability of DEKOMTE fabric expansion joints.



---

# Contents

3	Scope of Supply - Design for Integration, Formed Solutions
4	Technical Services, Inspection and Installation
5	Movements
6	Economical Value Analysis, Probability Curve and Technical Standards
7 - 8	Type 1
9 - 10	Type 10
11 - 12	Type 2U
13	Type 1R
14	Type 1RF
15 - 16	Type 3W
17 - 18	Type ME
19 - 20	Material Properties, Material Properties - Membranes
21	RAL - GZ 719
22	Quality Assurance

---

# Products

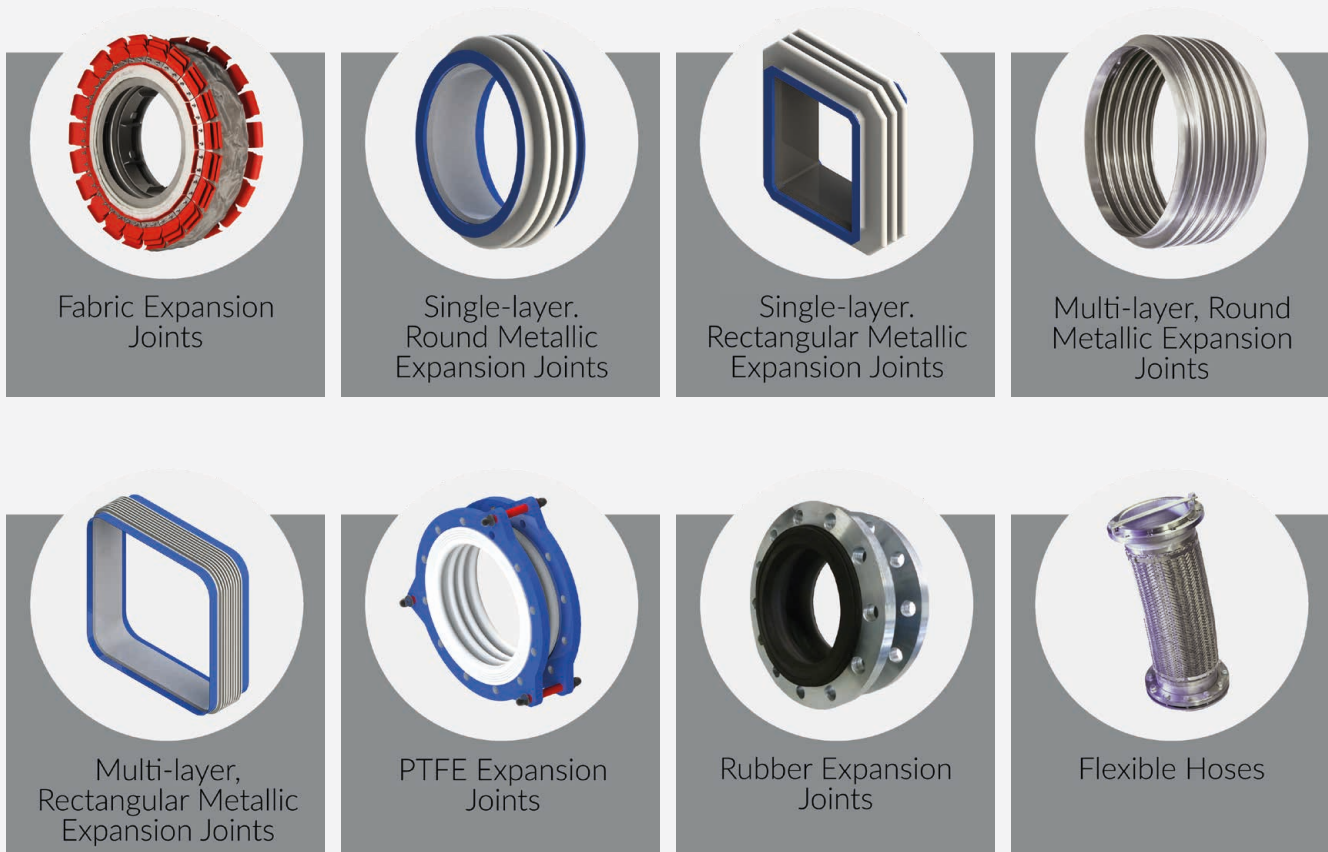

---

## Scope of Supply - Design for Integration

DEKOMTE fabric expansion joints are available in any geometric shape (round, square, oval, multi-sided) and in any size.

The scope of design responsibility is a key aspect of DEKOMTE philosophy for an integrated solution to the adjacent duct; this ensures no weakness in the steel frame, liner plate or insulation system.



A metal frame, flow plate, liner system, backing bars, fixings and insulation all form part of the scope that creates a reliable expansion joint. DEKOMTE is able to consider the impacts of turbulent flow, pressure variations, vibration to the expansion joint and the surrounding environment.

External features such as heat convectors for a reliable fixing system, can be a key design aspect for the fabric and clamping area to function.

Adjacent jacketed insulation systems can be used to aid the interfaces to external ducting telemetry or insulation.

Personnel guards and external protection equipment can be integrated with the expansion joint to give a package of supply and make the installation as straight forward as possible.

---

## Formed Solutions

DEKOMTE manufacture bespoke tailor-made solutions, utilising moulds and forms that create an expansion joint to a desired shape. The purpose of a mould is to allow movements to take place without any creasing or folding of materials.

A smooth and formed joint maintains a constant and even surface temperature which reduces the thermal stress and any fatigue to the materials and important gas membrane.

Formed joints are essential in all high movement requirements, where creasing causes rapid material degradation and failure.



---

# Technical Services, Inspection & Installation

## Design Studies and Technical Support

Design comparison, investigation and modelling can be achieved using the extensive database of empirical knowledge at DEKOMTE. We offer objective technical support at short notice for critical problems.



## Engineering Services

DEKOMTE pushes the boundaries of product development with the latest computer and industry best practice tools and procedures.

The discerning use of Finite Element Analysis (FEA) and Computational Fluid Dynamics (CFD), together with 2D and 3D design software, allows a correlation of on-site empirical experience and theoretical models. The formulation of specifications, tenders and design critique are also offered as an independent technical service.

## Inspection and Maintenance

DEKOMTE has experienced site engineers and designers who are able to review all expansion joints in a plant. We produce a technical report for maintenance planning and plant improvement, establishing a baseline of the sites expansion joints and helping to build a plan to reduce total costs. This includes:

- Visual and thermographic inspection
- Create a condition report on all existing joints on the plant:
  - » Evaluation of fixing system and gas tightness
  - » Review of adjacent elements for corrosion, cracking or distortion
  - » Internal review of expansion joint, including the flow plate and lining systems



## Turnkey Installation

The use of skilled design engineers, technicians, and service engineers, together with qualified on-site skilled labour means DEKOMTE offers a complete turnkey contracting solution for duct problems.

# Movements

Axial Movement - Compression

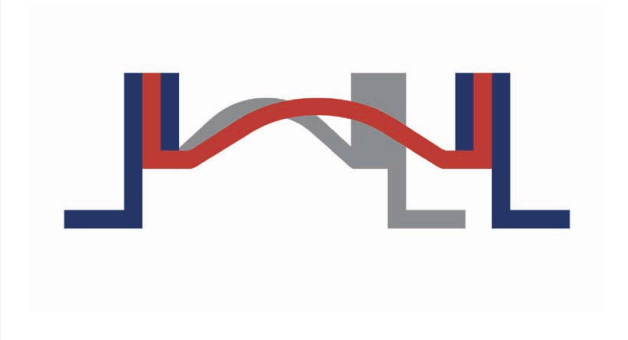

Axial Movement - Extension

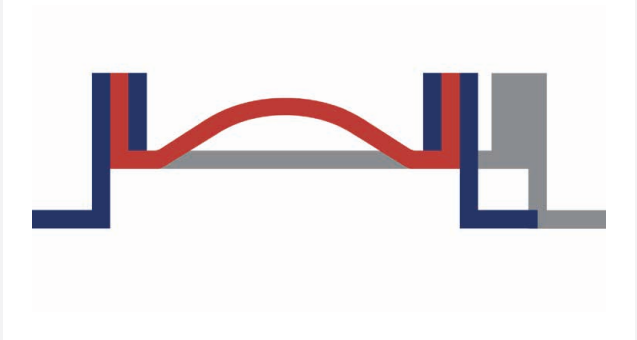

Lateral Movement

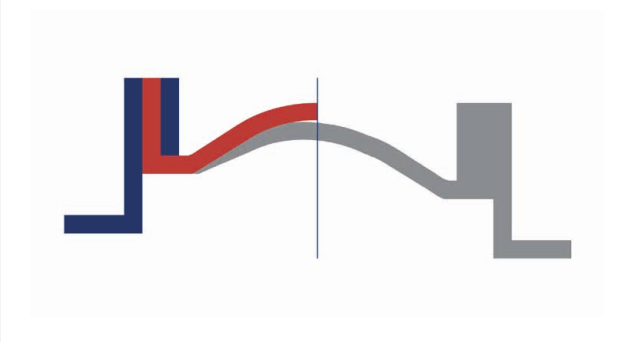

Angular Movement

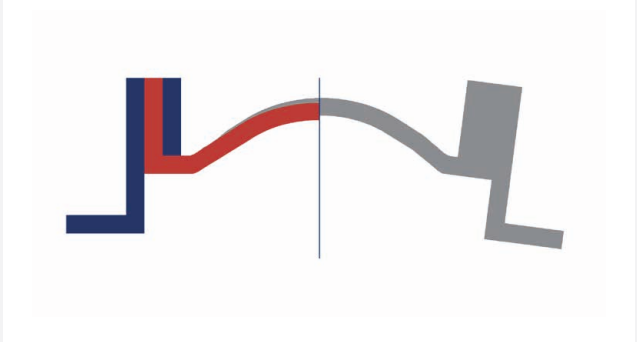

Fabric expansion joints are multi-layer systems, consisting of:

- Temperature and corrosion-resistant insulating fabrics
- Gas impermeable films, including:
  - » Foils - stainless, aluminium or Inconel
  - » PTFE and composites
  - » Silicone and rubber
- UV and water resistant materials for external protection

Part of the construction must also consider the supporting mechanical layers to give strength for maintaining the shape and resist pressure (normally internally, but also under negative pressure).

The overall form and shape of the joint is designed and constructed solely for the allowable movements required. Caution should be taken in any additional movement flexibility outside the specified movement envelope.



# Economical Value Analysis

DEKOMTE recommend a life cycle value analysis to evaluate the total cost of ownership for an end user. The OEM choices which compare the quality, technical level and cost, must be balanced against the long-term function required by a plant.

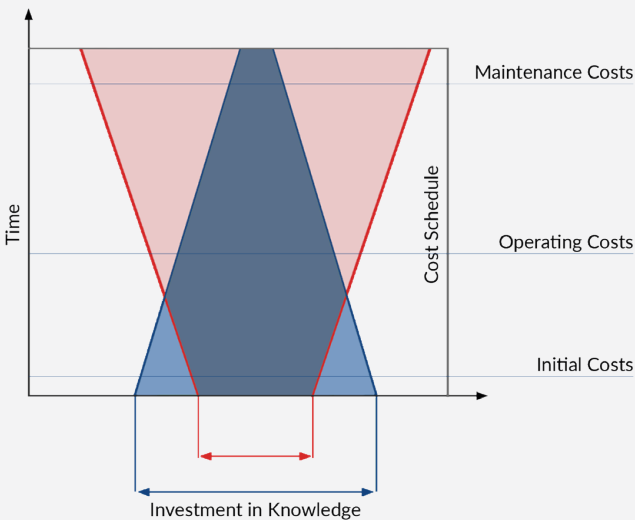

The costs associated with maintenance far outweigh the initial capital cost of equipment. DEKOMTE design and quality philosophy can give significant cost savings by an improved longer life initial solution.

DEKOMTE can provide assistance to develop the specification and selection criteria, giving a technical basis for understanding value in fabric expansion joint systems.

- Commercial impacts of the initial expansion joint selection
- Value and cost analysis requires technical evaluation:
  - » Requirements
  - » Solutions
  - » Value analysis

# Probability Curve and Technical Standards

DEKOMTE are able to offer varying levels of technical standard to reach a budget and lifetime required by the customer.

Curve 1 shows that the function of expansion joints in standard quality will cease after the guarantee expires. The supplier of these expansion joints is only interested to endure the guarantee period. If the plant wishes to have longer availability, it will require maintenance and replacement at additional cost.

Curve 2 and 3 present an expansion joint design of high / higher quality with a technically high availability and which reflects the performance of an engineering-focused supplier.

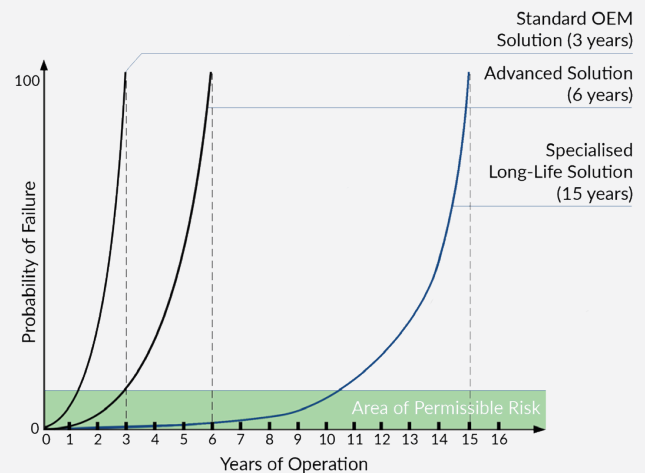

---

# TYPE 1

Applications: Standard application flat band joint suitable for ventilation and exhaust at moderate temperature and load. Fixing system often with clamp bands, but also with bolted systems for greater security and tightness.

---

Round

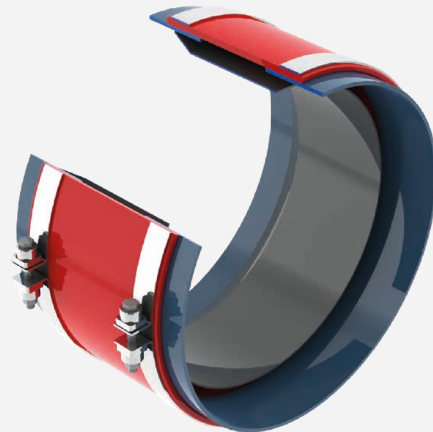

---

Form

1G (straight)



1W (convolution)



1F (fold)



---

Flow Plate

Without



Welded







---

# TYPE 10

Applications: Suitable as an exhaust expansion joint design for applications with demands for noise protection. Principally the solution for base load or low cycle life operating plants.

---

Round



Rectangular

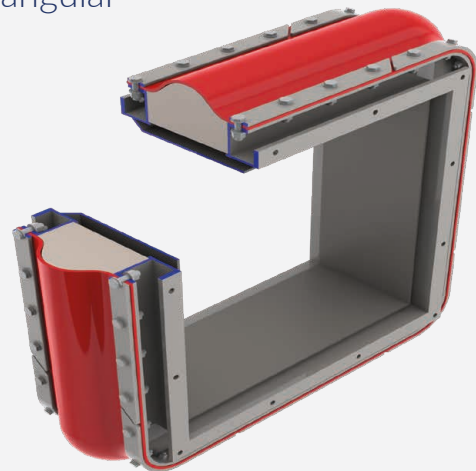

---

Form

10G (straight)



10W (convolution)



10F (fold)



---

Flow Plate

Without



Welded

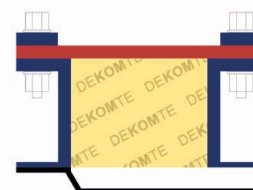



---

# TYPE 2U

Applications: Universal application for increased tightness requirements at temperatures up to 250°C.

---

Round

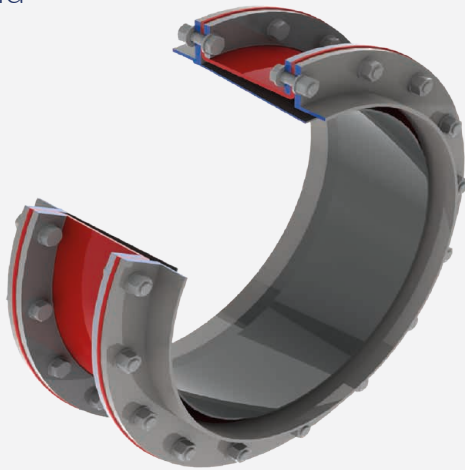

Rectangular

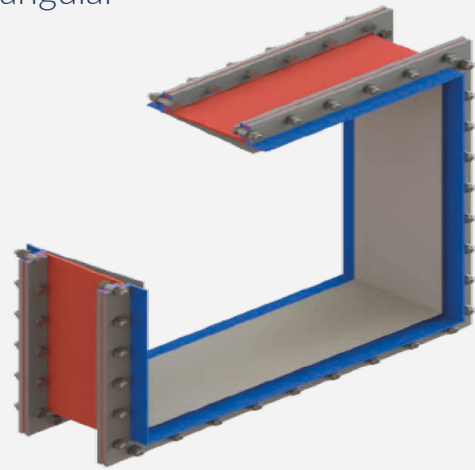

---

Form

2UG (straight)



2UJ (straight)



2UWA (convolution outside)



2UF (fold)



---

Flow Plate

Without



Clamped



Welded



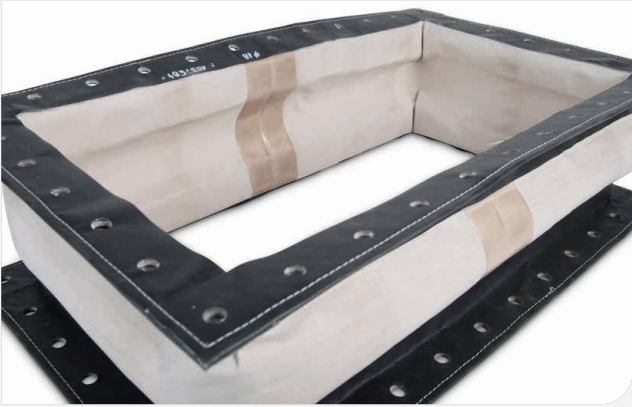

---

# TYPE 1R

Applications: Conical band joint suitable for standard applications, ventilation and exhaust at moderate temperature and load. Fixing system often with clamp bands, but also with bolted systems for greater security and tightness.

---

Round

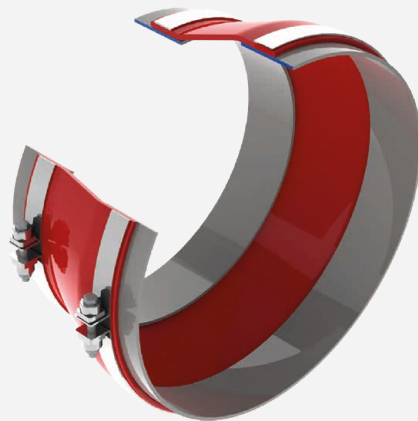

---

Form

1RG (straight)



1RW (convolution)



1RF (fold)



---

Flow Plate

Without



Welded

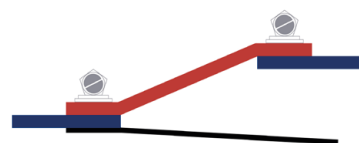

---

# TYPE 1RF

Applications: Conical right angled band joint suitable for Standard applications, ventilation and exhaust at moderate temperature and load. Fixing system often with clamp bands, but also with bolted systems for greater security and tightness.

---

Round

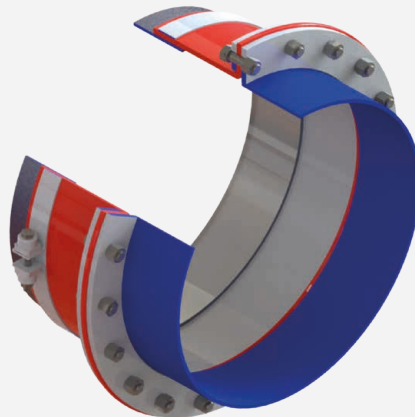

---

Form

1RFG (straight)



1RFW (convolution)



---

Flow Plate

Without



Welded



---

# TYPE 3W

Applications: Universal application at high movement absorption. Complete concept solution for applications with a high number of load cycles and dynamic loading gas turbines.

---

Round 3WA

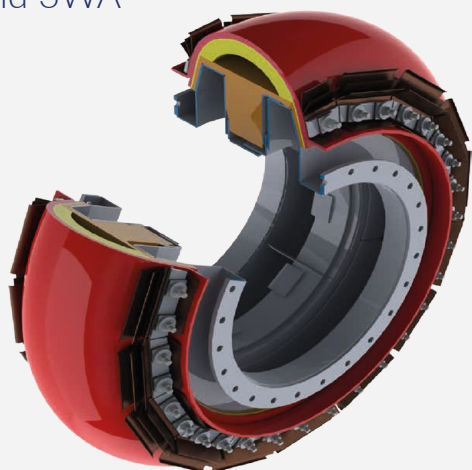

Round 3WI

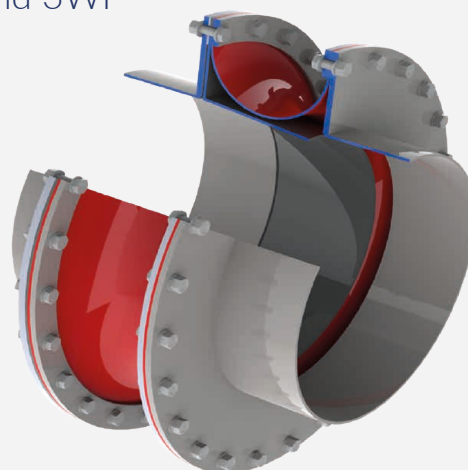

---

## Form

3WA (convolution outside)

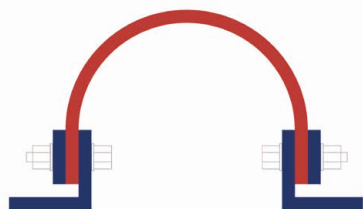

3WI (convolution inside)

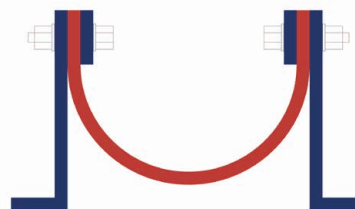

---

## Flow Plate

Without

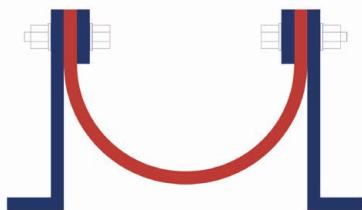

Clamped

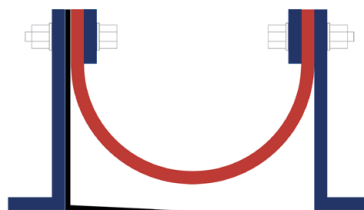

Welded

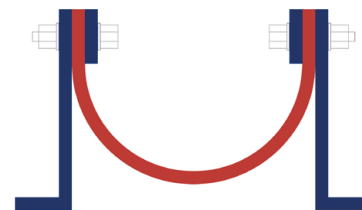



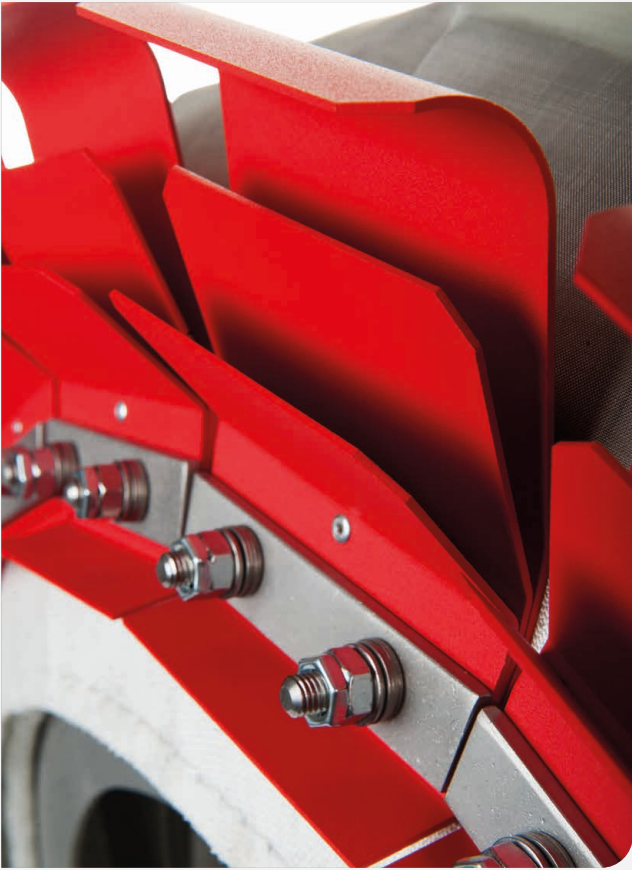

---

# TYPE ME

Applications: Conical membrane shaped joints are suitable for applications involving large movements at higher temperatures where high movement cycling is required. Normally combined with a special frame and fixing system to ensure flexibility and reliability of a system.

---

Round

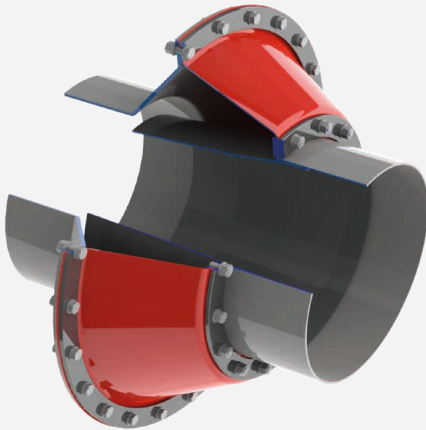

Rectangular

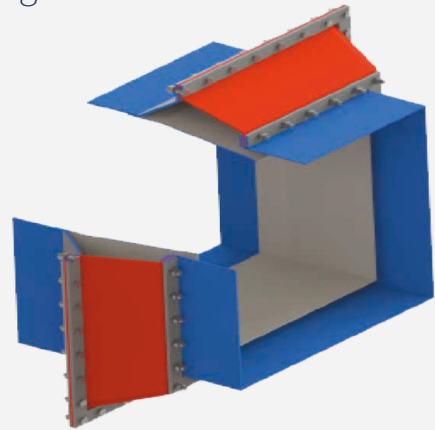

Form

---

ME

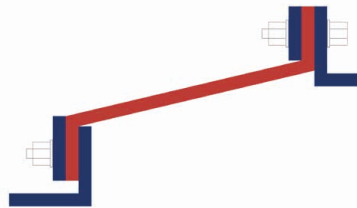

Flow Plate

---

Without

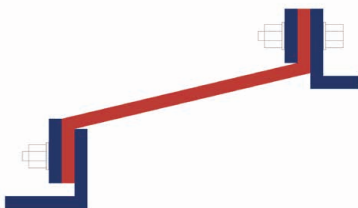

Welded

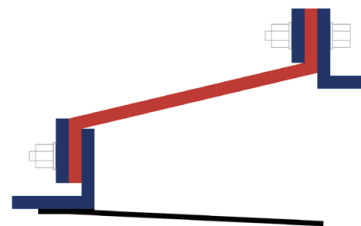



# Material Properties

	Material Number	Thickness (mm)	Temperature (°C)	Surface Weight (g/m <sup>2</sup> )
<b>Glass Fabric</b>				
Thermo B 1300	24	1	1000	1100
Thermoqua 400	20	0.43	400	420
Thermoqua 800	16	0.9	550	800
Thermoqua 1100	17	1.3	550	1080
Thermoqua 1300	18	1.6	550	1150
Thermoqua 2000	19	3.4	550	1900
Thermotex 1225	23	2.3	700	1300
Thermotex 1100 HT	110	1.25	1200	1100
<b>Metal Foil / Wire Mesh</b>				
Aluminium Foil	55	0.1	500	270
Inconel Foil	53	0.05	1000	400
Stainless Steel Foil 1.4828	56	0.05	1000	395
Stainless Steel Foil 1.4828	150	0.15	1000	1200
Stainless Steel Foil 1.4541	52	0.05	550	400
Wire Mesh 1.4301 M12 / M26 / M50	3 / 2 / 80	0.6 / 0.4 / 0.4	550	400 / 500 / 1000
Wire Mesh 1.4828 M12 / M26 / M50	6 / 6 / 100	0.6 / 0.4 / 0.4	1000	400 / 500 / 1000
Wire Mesh 1.4404 M12 / M26	8	0.6 / 0.4	1000	400 / 500
Wire Mesh 2.4816 M26	101	0.4	1000	990
1.4301 ≡ 304   1.4828 ≡ 309   1.4404 ≡ 316   1.4541 ≡ 321   2.4816 ≡ Inconel 600				
<b>Other Fabrics</b>				
Alufix 1	78	0.7	500	680
Alufix 2	75	1.3	500	1100
Kevlar 500	74	1.6	300	480
Kevsil 3	36	1.7	180	1500
Polyester Hypalon	33	0.5	90	660
PVC-W3	57	3	60	3000
				<b>Density (kg/m<sup>3</sup>)</b>
<b>Insulation</b>				
DEKOMTE HT Wool 10	10	12.7	1000	128
DEKOMTE HT Wool 20	11	19.1	1000	128
DEKOMTE HT Wool 50	12	50	1000	96
DEKOMTE HT Wool 50 (128)	116	50	1000	128
Glass Wool	14	50	500	15
Isotex	7	10	650	
Stone Wool	13	50	600	88

## Material Properties - Membranes

	Material Number	Thickness (mm)	Temperature (°C)	Surface Weight (g/m <sup>2</sup> )
<b>PTFE</b>				
Petex 204 HS	154	1.16	280	1870
Petex 209 / 3 HS	156	1.01	280	1561
Petex Noir	140	0.3	260	590
PetexFlon ½ - 1500 / 2000	142 / 143	1.2	280	2035
Peton 0.15	41	0.15	260	296
Peton 0.25	42	0.25	260	455
Peton 0.35	43	0.3	260	605
Peton I AS / II AS	87 / 88	0.36 / 0.22	260	700
PTFE 0.2	44	0.2	260	480
PTFE 0.4	45	0.36	260	860
PTFE 10 HS	137	0.1	250	228
PTFE 13 HS	138	0.13	250	
PTFE 23 HS	139	0.23	250	459
Thermoflon ½	48	1.2	250	1610
Thermoflon ½ - 640	145	0.82	250	950
Thermoflon ¼	49	1.6	250	2100
Thermoflon 2	50	1.38	250	2175
Thermoflon 2 - 640	51	1.4	250	2050
<b>Rubber</b>				
Elperbun	47	0.8	100	1010
EPDM - with wire	95	3.5	100	8560
EPDM - with fibre and wire	97	4.5	100	9770
EPDM - with double wire	91	6	100	2850
EPDM - with double fibre	129	4.5	100	5000
FKM - with wire	92	3.5	170	8470
FKM - with fibre and wire	93	4.2	170	6800
FKM - with double wire	96	6	100	4670
<b>Silicone</b>				
Silitex 1 (white, red)	121 / 28	1.1	180	1400
Silitex 2 (white, red, black)	125 / 29 / 123	0.55	180	750

# RAL - GZ 719

Key tasks of the Quality Association for fabric expansion joints are:

- Reliable use of the products in all application fields
- Continuous amendments of the state of the art for optimum product quality:
  - » By quality and inspection specifications
  - » By technical information optimised regarding cost and benefit

Fabric expansion joints can be used for all types of media in many duct arrangements and countless applications. The user must be sure that by using these elements:

- The application risks are minimised
- Extreme requirements can be fulfilled
- Durability and reliability of the products are provided



Item	Title
TI-001	Determination of tensile strength of supporting layers for fabric expansion joints
TI-002	Flue-gas tight fabric expansion joints
TI-003	Nekal-tight fabric expansion joints
TI-004	Expansion joint questionnaire
TI-005	Tightness test of fabric expansion joints with foam building liquid
TI-006	Documentation of fabric expansion joints
TI-007	Bolted connections for fabric expansion joints
TI-008	Storage, packing and transportation of fabric expansion joints
TI-009	Planning of installation for fabric expansion joints
TI-010	Installation of fabric expansion joints
TI-011	Insulation requirement for fabric expansion joints
TI-012	Maintenance of fabric expansion joints during shut-down period
TI-013	Tolerances for connection flanges and installation dimensions for fabric expansion joints
TI-014	Glossary
TI-015	Safety management of fabric expansion joints
TI-016	Surface temperature of fabric expansion joints
TI-017	Remarks about EC Declaration of Conformity and CE marking of fabric expansion joints
TI-018	Inspection documents according to EN 10204 for fabric expansion joints

With the increased quality demands according to RAL-GZ 719 and the associated technical information, DEKOMTE automatically fulfils and exceeds the quality demands of the European Sealing Association (ESA) and the American Fluid Sealing Association (FSA).

---

# Quality Assurance



## Quality - ISO 9001:2015

The DEKOMTE management team commit themselves to take independent responsibility of the quality of the contractually agreed conditions, standards and other regulations and the associated legal obligations. The DEKOMTE management team actively supports the consistent further development of the system in compliance with the imposed requirements.

## Safety - ISO 45001

DEKOMTE recognises that its activities give rise to a range of hazards, in particular: manual handling, use of machinery, work on site at height and IT. It also recognises that its employees may be exposed to hazards when providing on-site support to their customers.

DEKOMTE believes that despite the presence of these hazards, all accidents and incidents of work related ill-health are preventable. It also recognises it has a legal responsibility to ensure the health, safety and welfare of persons affected by its activities.

## Environment - ISO 14001:2018

DEKOMTE has a responsibility to help protect the environment wherever it has an opportunity to do so and to provide a good environment for its employees to work in.

## Fabrication

DEKOMTE hold manufacturing and workshop execution class EXC3 accreditation, EN1090 and ISO 3834-2 for base materials. Approved and applied methods include arc welding, part-mechanised Tungsten-inert gas metallic arc welding and part-mechanised active-gas welding. DEKOMTE welders are approved and accredited to ISO 9606-1 / ISO 14732.

The personnel for non-destructive testing of welding seams (NDT) is accredited according to ISO 9712.

**EJMA** - DEKOMTE metal expansion joints are in accordance with EJMA (10th Edition) and AD B13.

**PED** - DEKOMTE de Temple Engineering SRL has the certification accredited to AD 2000-Merkblatt HP 0, TRD 201 and EN ISO 3824-2. Therefore DEKOMTE is able to manufacture pressure equipment accredited to "Pressure Equipment Directive 2014/68/EU".

---

www.dekomte.com



**Headquarters - Germany**

info@dekomte.com  
+49 6182 21014



**The Netherlands**

info@vermeul.nl  
+31 172 509980



**France**

info@dekomte.fr  
+33 134387960



**Belgium**

info@dekomte.be  
+32 5951 0755



**Czech Republic**

dekomte@dekomte.cz  
+420 596 244026



**Spain**

info@dekomte.es  
+34 93 467 6021



**Italy**

info@dekomte.it  
+39 350 9640274



**United Kingdom**

info@dekomte.co.uk  
+44 845 458 8125



**USA**

info@dekomte.us  
+1 678 214 6544