



SPACECOMBI CLASSIC

MKN No.: SKE061R_CL_G2



MKN combi steamer compact 6 tray, Gastronorm 1/1 with manual operation system.

Product Advantages:

- Hygienic rounded corners and cooking chamber door with insulated **triple glazing**.
- Saves energy due to low heat loss, work safety due to low outside temperature.
- **5 fan speeds**, auto reverse fan for best cooking uniformity.
- **Up to 100 individual cooking programmes** can be stored in up to 6 steps.
- USB interface.
- High speed centrifugal steam generation technology with heat recovery.
- **ClimaSelect** – Humidity and temperature control measurement.
- **WaveClean** – Automatic cleaning system (safe, easy, economical).
- **3 years warranty parts and labour.**

Installation requirements:

- Soft Water / Water supply / Connection to waste water provided by customer.
- If mineral content is high, reverse osmosis system may be advisable.

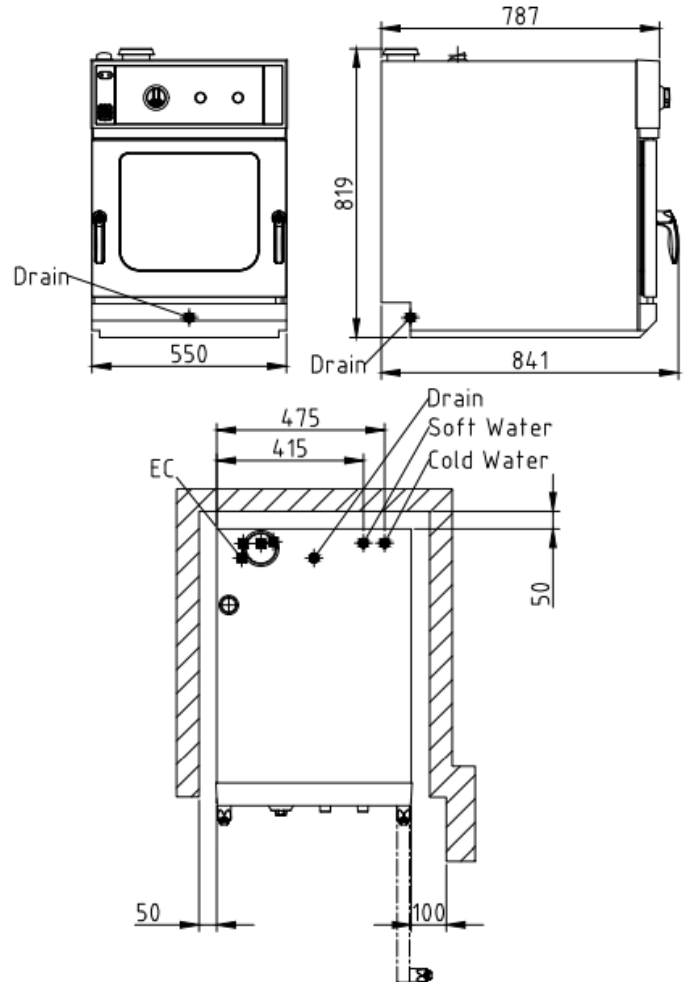

Technical Data:

Width x Height x Depth (mm)	550 x 819 x 787
Connected load (electrical) (kW):	7.8
Voltage (V) / EC:	415 3 phase AC
Recommended fuses (A):	3 x 20
Frequency range (Hz):	50
Soft Water connection:	DN 20 (R ¾" inside)
Water connection:	DN 20 (R ¾" inside)
Waterpressure (kPa):	200 - 600 (2 - 6 bar)
Drain connection:	DN 40
Gastronorm 1/1 (530 x 325 mm):	6 (max. 60 mm deep)
Plates Ø 28 cm:	12
Material housing:	1.4301
Material cooking chamber:	1.4301
Net weight (kg):	80
Heat emission latent (W):	1404 (or 421 with HoodIn)
Heat emission sensitive (W):	936
Type of protection:	IPX 5