

DETAIL "B"

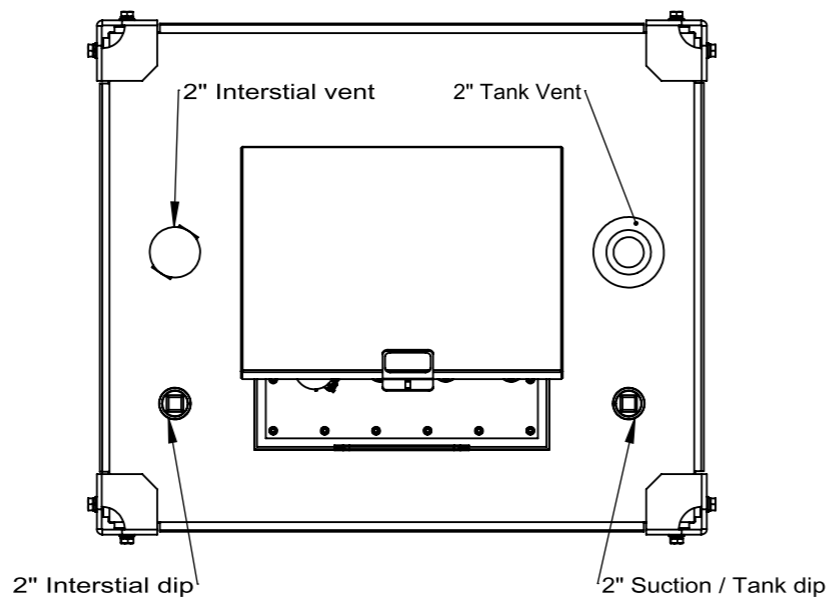
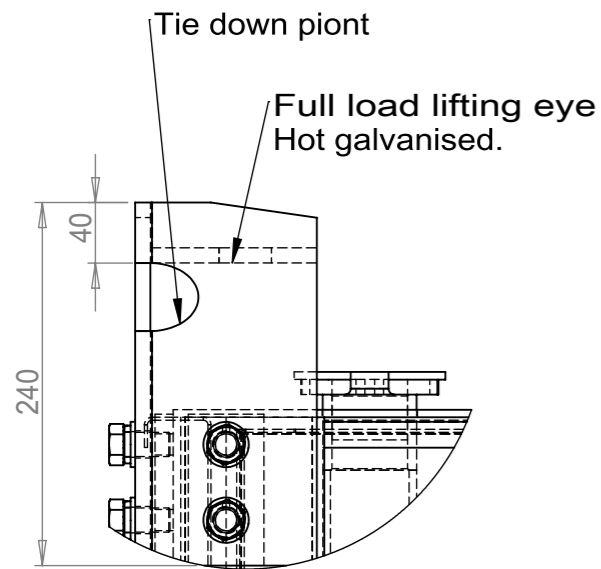
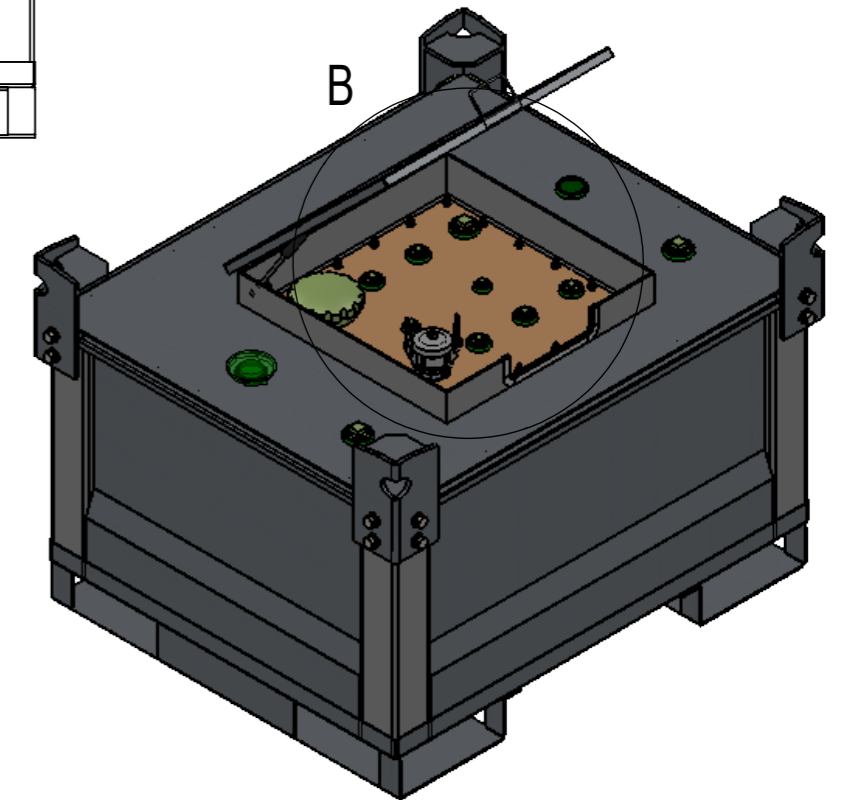

DETAIL "A"

1. Stackable 2 high full and 3 empty.
2. Designed and approved to AS1940 / AS1692 / AS1657
3. All welding to AS1554.1
4. All threads are BSP
5. Self bunded (double wall) for stationary storage
6. 2" socket fill point
7. Four way forklift pockets
8. Statutory signage

Size	Tank Capacity (L)	Safe Fill Level (L)	Length (mm)	Width (mm)	Height (mm)	Empty Weight (kg)
CUBE 450L	500	450	1210	1020	830	350

							TITLE NO. :	
							BDM CUBE	
							PART NO. :	
NO.	Changes File	SIGN	DATE	Material	Weight	Scale	JOB NO 450L	
Design	2018/9/4	Number						
CHK'D								
CHK'D								
APPV'D								
				Revision	01	SHEET 1		TOTAL SHEET 2

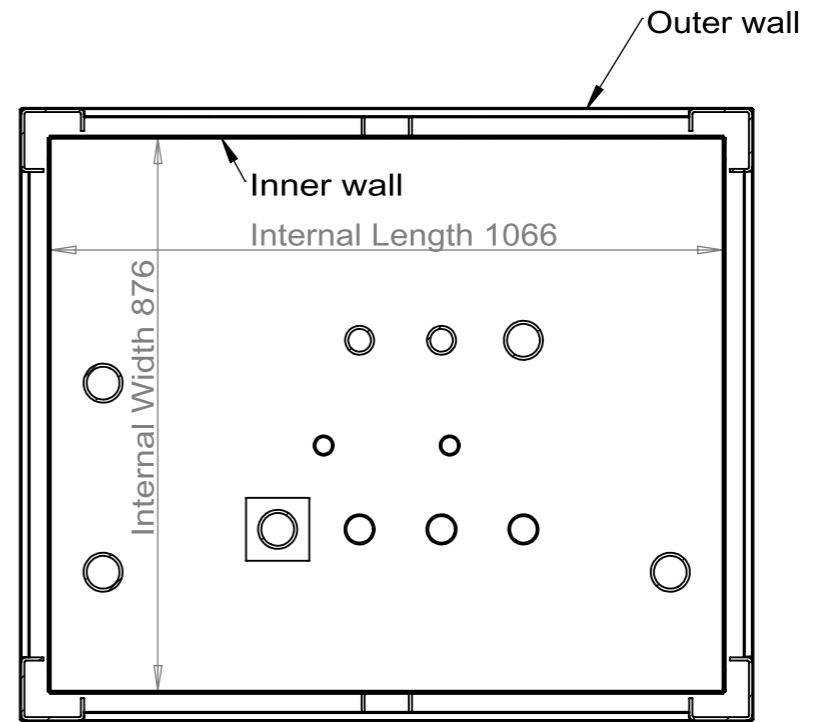
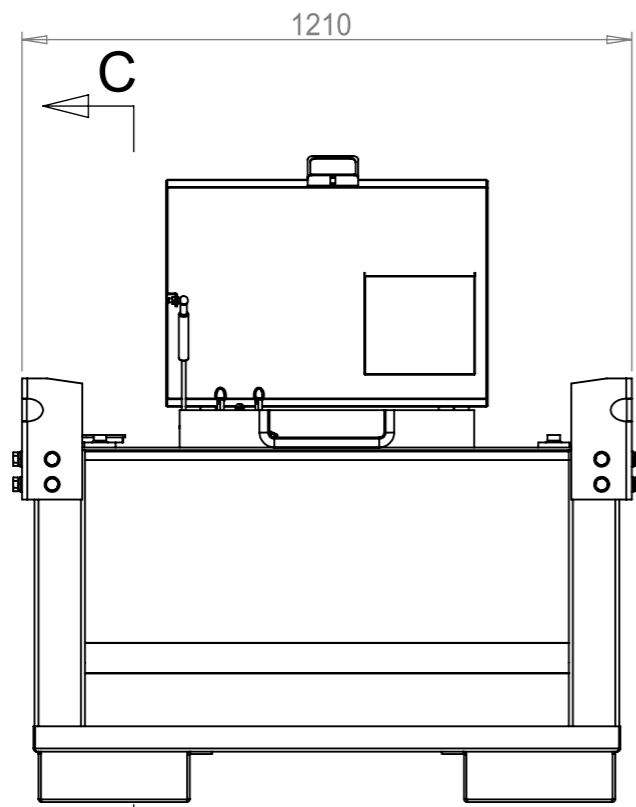

D-D

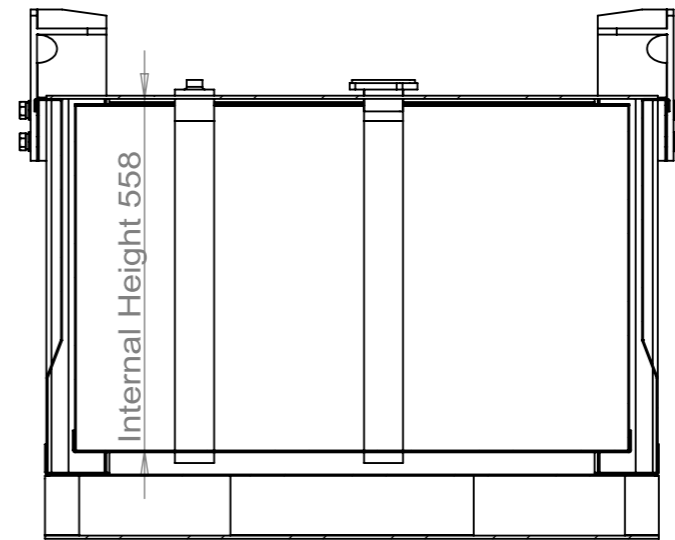
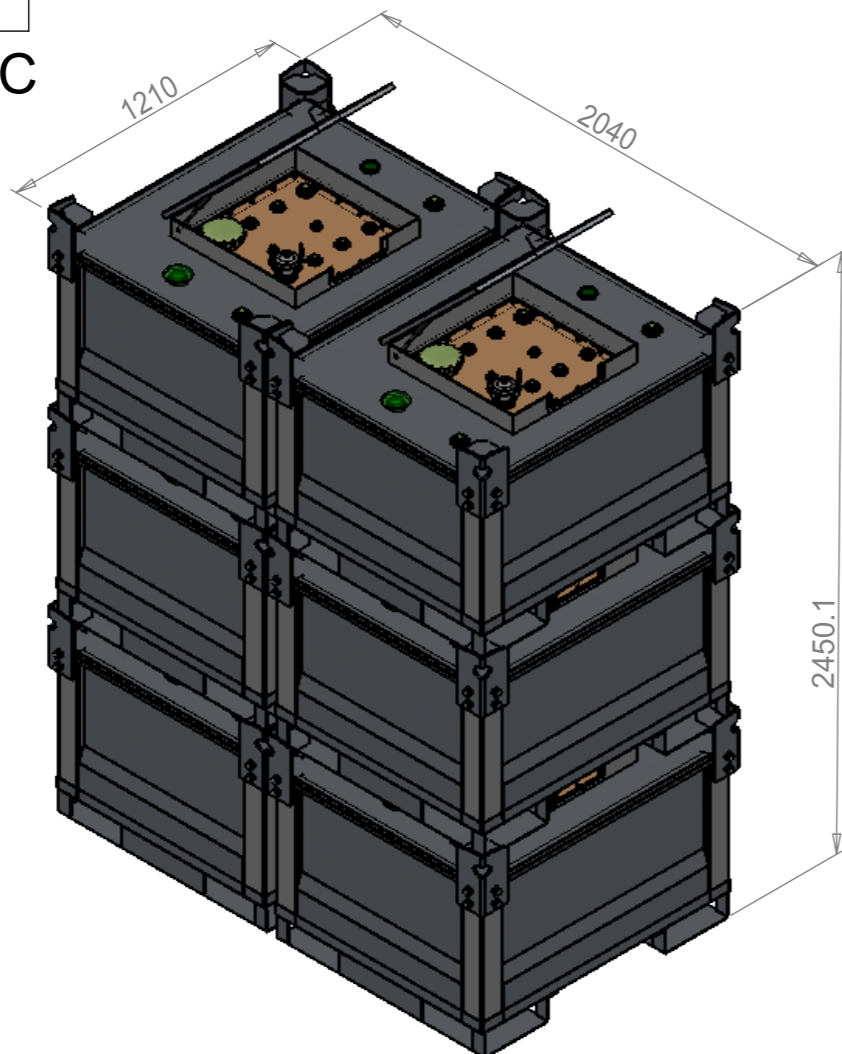

C-C

TANKS CAN BE STACKABLE FOR DELIVERY

							TITLE NO. :	
							BDM CUBE	
							PART NO. :	
							JOB NO. 450L	
NO.	Changes File	SIGN	DATE	Material	Weight	Scale		
Design	2018/9/4	Number						
CHK'D								
CHK'D								
APPV'D								
				Revision	01	SHEET 2		TOTAL SHEET 2