



**MALMET (AUSTRALIA)
PTY LTD**

Infection Control Solutions &
Specialised Hospital Equipment

ES-D

**Bedpan/Urine Bottle
Washer Disinfector**





ES-D Malmet Bedpan/Urinal Bottle Washer Disinfector

Malmet ES-D Bedpan/Urinal Bottle Washer Disinfector range is the most efficient and effective method of washing and disinfecting bedpans and urinal bottles.

Independently micro-tested, Malmet ES-D devices are proven to inactivate organisms (bacteria and viruses) generally found in bedpans and urinal bottles.

The detergent wash ensures that faeces etc are properly removed before the final steam disinfection, ensuring efficacy to the highest relevant Australian and ISO standards. Also, designed with the environment in mind, the ES-D range of products has one of the lowest energy usage rates in the industry.

- Low water and power consumption
- Large capacity: 1 bedpan and 2 urinal bottles per cycle
- Standard universal rack will also accept bariatric slipper pan
- Detergent cycle
- Infection Control: Microbiologically tested by an independent NATA certified laboratory
- Hands-free operation to minimise infection control risk
- Simple controls, easy to operate
- Steam disinfection with inbuilt steam generator – no external hot water supply required
- Disinfection to higher AO 600 level as recommended by ISO 15883
- No venting required
- Available in 240 V 10 A and 240 V 20 A
- Compliant to relevant electrical safety, Watermark standards
- ARTG Certification 232012 to industry highest Class 11b level
- Malmet Door Obstruction Feature - This is factory set to 12 Nm \pm 10%; causing the door to re-open when an obstruction is detected. This is designed to protect the integrity of the device and the articles within.



Model Available

Product Code	Model No	Description	Average Cycle Time	Power Consumption	Water Consumption Cold Water Only
91-1002	ES915S-D	Malmet Bedpan/Urinal Bottle Washer Disinfector (S Trap, 1 Phase 20 Amp)	5.30 min	0.300 kwh	36 litres
91-1007	ES915P-D	Malmet Bedpan/Urinal Bottle Washer Disinfector (P Trap, 1 Phase 20 Amp)	5.30 min	0.300 kwh	36 litres
91-1022	ES935S-D	Malmet Bedpan/Urinal Bottle Washer Disinfector (S Trap, 1 Phase 10 Amp)	7.50 min	0.236 kwh	36 litres
91-1027	ES935P-D	Malmet Bedpan/Urinal Bottle Washer Disinfector (P Trap, 1 Phase 10 Amp)	7.50 min	0.236 kwh	36 litres

Detergent

Product Code	Description	Volume
81-9071SP	PK 4 – Detergent Malmet	4 x 5 Litres



Specification Table

Dimensions:	595 mm W x 660 mm D x 1305 H
Power Input	240V Single Phase @ 10 Amp or 20 Amp 50 Hz
Power Consumption:	20 Amp - 0.300 kwh, 10 Amp - 0.236 kwh
Water Inlet:	GB ¾ Male
Water Supply	5 - 25°C @ 100 - 400kpa Nominal Flow Rate 10L/Min
Concentration of multivalent cations (Water Hardness)	2.5 mmol/l of CaCO ₃
Soil Line:	100 mm 'S' or 'P' Trap
Shipping Weight:	110 kg
Chamber Volume:	43 L
Capacity:	1 x bedpan & lid & 2 Urinal bottles OR 1 x commode bowl & lid & 2 urinal bottles OR 1 x small or bariatric slipper pan & lid & 2 urinal bottles
Detergent:	5 Litre Product Code #81-9071SP (Detergent ARTG Certification 190013)
Detergent Dosage:	30ml
Detergent Specifications	Poisons Schedule: 6 Dangerous Goods Class: 8, Hazchem Code: 2R





ES-D Dimensions and Service Locations

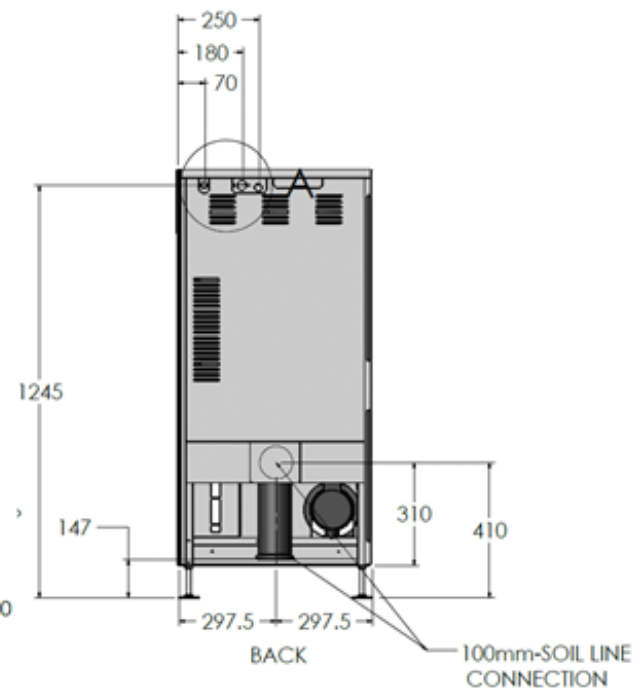
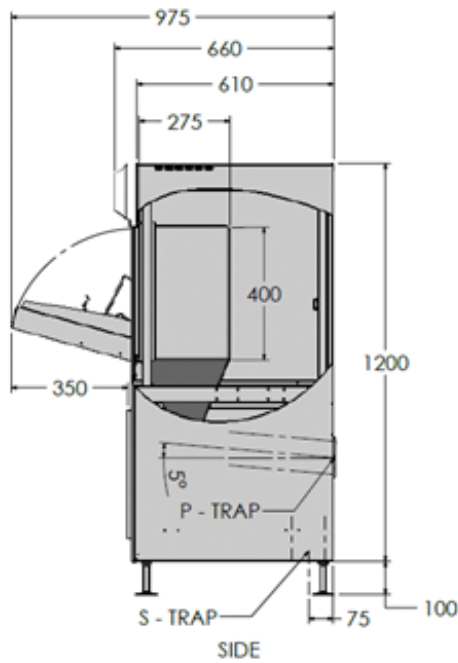
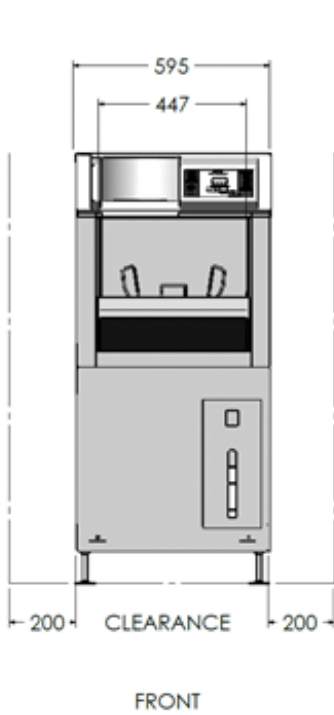
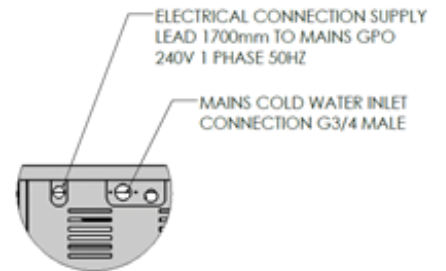
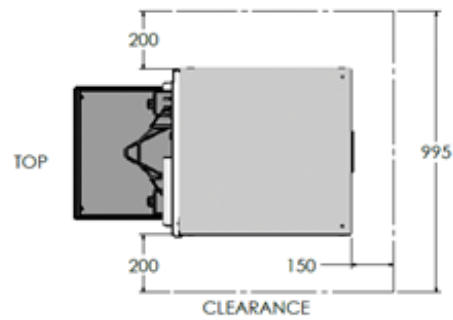



Urinal Bottle Racks

Product Code	Model	Description	Size (mm)		
			Width	Height	Depth
8-M00-80-131	BR4WT	Malmet Rack (For 4 Urinal Bottles with wall plate and drip tray)	630	209	115
8-M00-80-133	BR6WT	Malmet Rack (For 6 Urinal Bottles with wall plate and drip tray)	790	209	115
8-M00-80-134	BR8WT	Malmet Rack (For 8 Urinal Bottles with wall plate and drip tray)	1,043	209	115

Bedpan and Basin Racks

Product Code	Model	Description	Size (mm)		
			Width	Height	Depth
8-M00-80-231	PR4WT	Malmet Rack (For 4 Urinal Bottles with wall plate and drip tray)	630	437	300
8-M00-80-233	PR6WT	Malmet Rack (For 6 Urinal Bottles with wall plate and drip tray)	790	437	300
8-M00-80-234	PR8WT	Malmet Rack (For 8 Urinal Bottles with wall plate and drip tray)	1,043	437	300

Combination Racks

Product Code	Model	Description	Size (mm)		
			Width	Height	Depth
8-M00-80-321	BR4-PR4+WT	Malmet Rack (For 4 Bedpans & 4 Urinal Bottles with Wall Pate & Drip Tray)	630	645	300
8-M00-80-323	BR6-PR6+WT	Malmet Rack (For 6 Bedpans & 6 Urinal Bottles with Wall Pate & Drip Tray)	790	645	300
8-M00-80-324	BR8-PR8+WT	Malmet Rack (For 8 Bedpans & 8 Urinal Bottles with Wall Pate & Drip Tray)	1,043	645	300

Urinal Bottle Rack



Bedpan and Basin Racks



Combination Racks

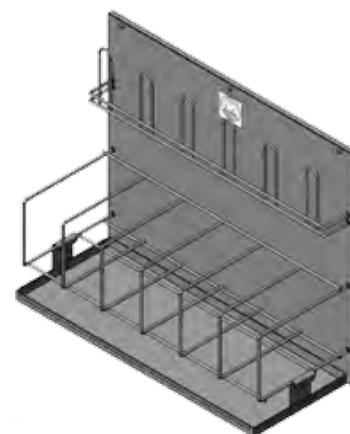



SERVICE DIVISION

Robust technology, easy to service, local spare parts

One of the cornerstones underpinning Malmart is our commitment to excellence in customer service. At all levels of our company - from the production floor to our sales and management staff - integrity and professionalism mark the way we do business.

Malmart Service manage the service for the Malmart brand of hospital equipment. All Malmart Service Technicians are comprehensively factory trained offering a professional and competitive service.

Urgent service/breakdown requests are attended to within a 24 hour period.

Malmart prides itself on achieving outstanding customer service satisfaction, obtaining 9/10 and higher on all Customer Service Quality Audits.

Malmart have their own service technicians to cover most of NSW/ACT, with authorised service agents for other areas. Interstate, Malmart have fully trained authorised service agents to cover most of Australia.

Preventative Maintenance Agreements and Validation Testing and Certification

With the changes to the Healthcare Industry accreditation process more facilities are required to show that all equipment is maintained according to the manufacturers recommendations. Malmart recognises this need and are pleased to offer Preventative Maintenance Agreements (PMA) for all Malmart products, and Validation Testing and Certification in accordance with AS5369:2023 and ISO15883

PMA's take into consideration the quality, age and usage of the products to give the most suitable scheduled competitive agreement tailored to the facilities requirements. Malmart or its authorised service agents can offer a competitive, professional PMA tailored to your organisation.





MALMET

Malmet (Australia) Pty Ltd is a privately owned and operated Australian family business belonging to the Celi Group of Companies.

Malmet is a leading manufacturer of Infection Control Solutions and Specialised Hospital Equipment and Aged Care Equipment for CSSD, Recovery, Obstetrics, Theatre and Ward Utility Rooms.

Malmet has been manufacturing hospital and aged care equipment since 1969, and supplies hospitals and nursing homes throughout Australia and the International market through a comprehensive network of distributors and agents.

All Malmet products are manufactured at the Malmet Leeton, NSW site which is ISO 9001 and ISO 13485 Certified.

Product Range



Tall Warming Cabinet
FWTFC

Malmet Instrument and Anaesthetic Apparatus Drying Cabinet
DC12

Malmet Fluid and Blanket Warming Cabinet
FBWFC

Malmet Blanket Warming Cabinet - with Stand
BWS

Malmet Utensil/Bowl Washer Disinfector, Top Loading
WDT2

Malmet Bedpan/Urinal Bottle Washer Disinfector
ES-D

Malmet Bedpan/Urinal Bottle and Utensil/Bowl Washer Disinfector
WDS

Malmet Rack (for Bedpan & Urinal Bottles with Wall Plate & Drip Tray)
BR6-PR6 + WT

National Head Office & Customer Service

For Correspondence:
9-11 McKay, Leeton, NSW 2705 Australia

General Sales, Service, Export Enquiries & Accounts

Ph. +61 2 6953 7677 Email: info@malmet.com.au

Warning:
This brochure contains general information only. If you require accurate dimensions or any other details which may affect your installation, please contact Malmet. E.&O.E. In the interest of continued product improvement, Malmet reserves the right to alter design and product specifications without notice. E.&O.E. For further information on warranty terms and conditions, please refer to Malmet's Warranty Statement.

MEDICAL RECEPTACLES SHOWN IN ALL PHOTOS ARE NOT INCLUDED WITH UNITS.

PBL006 0119

