

City Silent LED - Mobile

Model: ENV4UYMOBILE

EnviroLED

Lighting Towers

4 x 320W



Highly efficient

Urban spec

4 X 320W Multi LED

delivering super

bright light visibility

for road works

and building sites



BLUE DIAMOND
MACHINERY

EnviroLED

Lighting Towers

City Silent Urban LED Mobile
4 x 320W Model ENV4UYMOBILE

KEY FEATURES



- Four x 320W Multi LED



- Massive 166200 Lumen



- 5000 M2 @ 20 Lux

- Easy to use Deep Sea L401 controller.



- Super Fuel Efficient Japanese Yanmar engine with 200 Hour Run Time

MADE IN ITALY

Italian made for tough Australian conditions, delivering super bright light for continuous night work in construction and civil works.

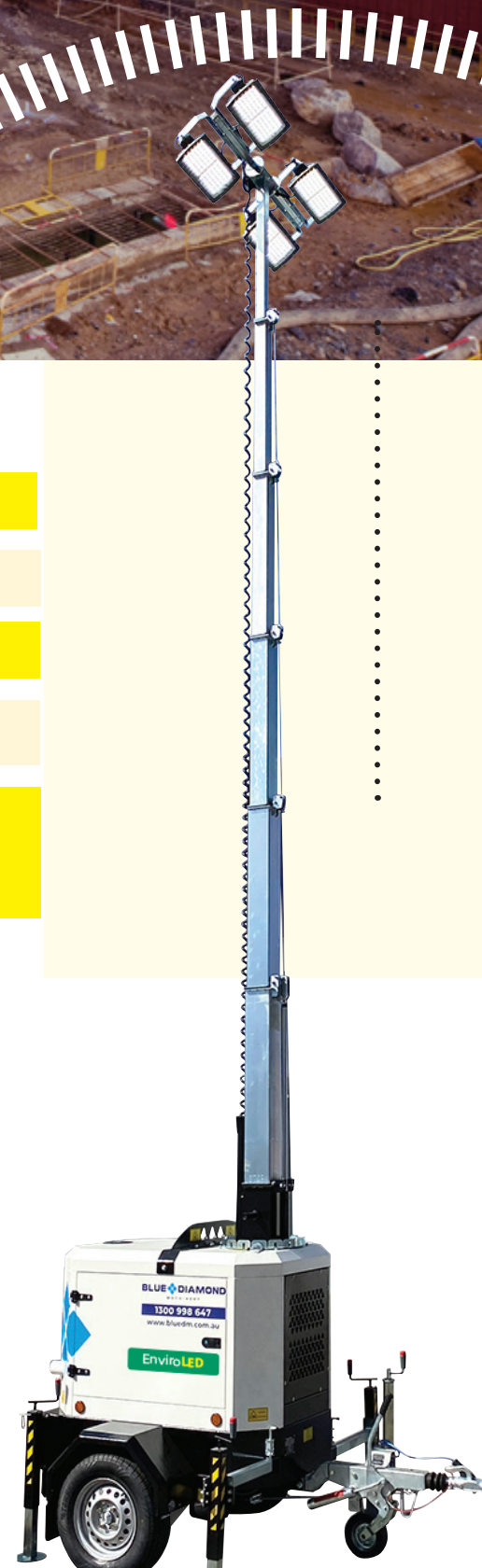

Lighting Towers Technical Specifications

Performance data	
Rated frequency / voltage	50 Hz / 230 V
Rated Power	3.5 kW
Operating temperature	-30/+50°C
Sound level	61 dB @ 7 m
Control unit	Deep Sea L401 MKII
Engine	
Yanmar 2TNV70	
Speed	1500 rpm
Coolant	Liquid
Cylinders	2
Emissions	Stage V
Alternator	
Linz Alumen	
Rated outlet	3.5 kVA
Regulation	Brushless
Voltage accuracy	+/- 5%
Auxillary power	0.5kVA
Fuel Consumption	
0,55 l/h	
Tank	110 l net/ 120 l gross
Fuel	Diesel
Running time	200 h
Galvanized mast height	
8.5 m	
Lifting system	Hydraulic
Rotation	350 °
Wind resistance	110 km/h
Trailer	
Road -towed trailer	
Tyres	185/70R13
Basement	Bunded base 120%
Stabilizers	4 + 1
Canopy	Powder coating paint
Optional	
Optional included as standard:	Weekly timer Autostart Grid/engine selector Daylight sensor with Autostart AMOSS kit Battery isolator
Optional not included:	Electric tilting head
Shipment	
Dimension	235x147x240 cm
Weight	850 kg
Truck	10
Container 40"HC	10

EnviroLED

Lighting Area (see MultiLed head on front page)

