

## TECHNICAL DATA SHEET FOR ROTEL BAKERY OVENS AUR3M3D3S, AUR3M4DHC AND AUR3M4D1S

### STANDARD FEATURES

VTL - variable temperature loading

- energy efficient
- ease of operation
- less down time

Live inbuilt steaming system fitted to all chambers

Interior lamps fitted standard to all chambers.

Each chamber individually controlled

Touch screen controllers mounted right hand side

### OVERALL CONSTRUCTION

Internal baking chambers stainless steel

Facia and sides stainless steel

Doors all stainless steel construction

Tempered 10mm thick door glass

Tray holders welded steel and fitted standard to all decks

Turntable drive system bottom mounted

Casters fitted as standard

### OPERATION

Touch screen controllers that operate with minimal staff input

Individual chamber control display

Icon category menu

Up to 99 baking programs (universal programming for all decks)

Programmable time, temp, steam and top/bottom heat balance

Automatic preheating of all decks

Automatic energy saving temperature set-back / idle

Split bake / multiple product program feature applied all decks

Manual bake mode

7 day auto-start

Low-temp bake mode

Automatic back up on event of controller failure

Temperature control range up to 270°C

Bake time range 0-120 minutes standard (adjustable to 256 minutes)



AUR3M3D3S



AUR3M4D1S

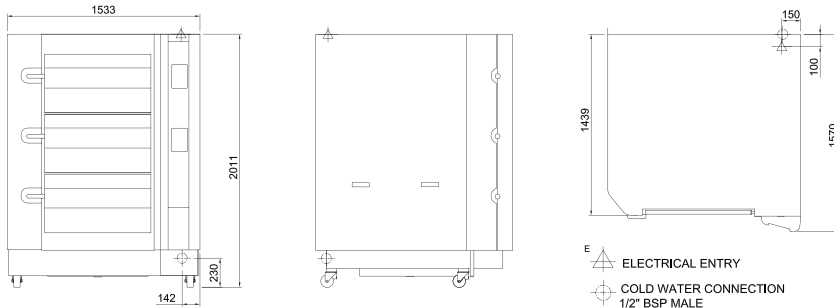

**AUR3M3D3S**

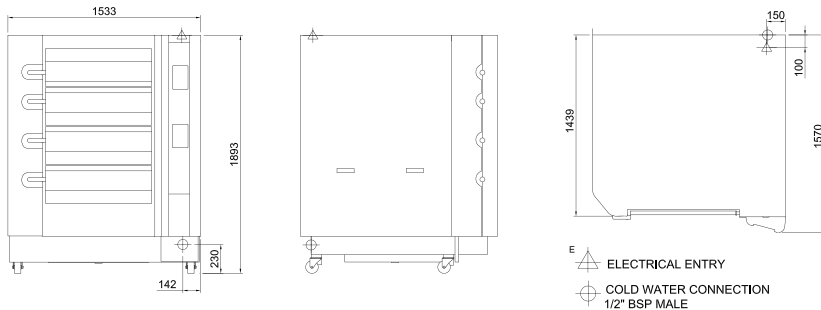

**AUR3M4DHC**

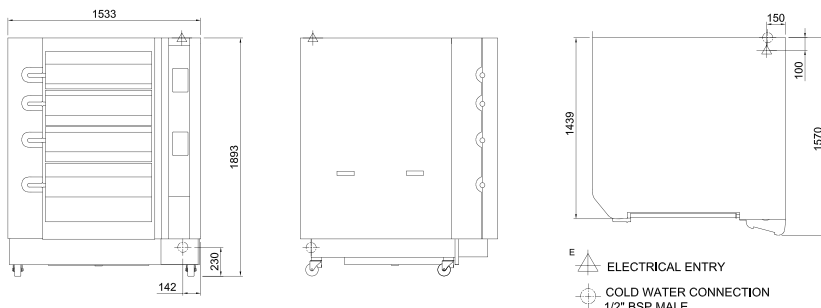

**AUR3M4D1S**

| Model            | Deck Configuration | Tray <sup>1</sup> Capacity | Loaf <sup>2</sup> Capacity | Dimensions W x D x H mm | Electrical Specifications    |
|------------------|--------------------|----------------------------|----------------------------|-------------------------|------------------------------|
| <b>AUR3M3D3S</b> | 3 deck, 3 split    | 12 tray                    | 60                         | 1533 x 1570 x 2011      | 34kW, 3P+N+E, 400-415v, 50hz |
| <b>AUR3M4DHC</b> | 4 deck, high crown | 8 tray                     | 48                         | 1533 x 1570 x 1893      | 24kW, 3P+N+E, 400-415v, 50hz |
| <b>AUR3M4D1S</b> | 4 deck, 1 split    | 10 tray                    | 60                         | 1533 x 1570 x 1893      | 29kW, 3P+N+E, 400-415v, 50hz |

<sup>1</sup> Oven chambers accept 16" and 18" wide trays

<sup>2</sup> Standard 680gm loaf

**Crown heights (usable)**

- Standard decks – 180mm (unless top deck)
- Top decks / HC – 200mm (unless split deck)
- Split decks – 170mm (unless top split deck)
- Top Split decks – 205mm / 135mm (offset split)

| Model               | AUR3M3D3S          | AUR3M4D1S          | AUR3M4DHC          |
|---------------------|--------------------|--------------------|--------------------|
| <b>Nett Weight</b>  | 850 kg             | 860 kg             | 860 kg             |
| <b>Packing Data</b> |                    |                    |                    |
| Weight              | 1010 kg            | 1020 kg            | 1020 kg            |
| Width               | 1710 mm            | 1710 mm            | 1710 mm            |
| Depth               | 1900 mm            | 1900 mm            | 1900 mm            |
| Height              | 2350 mm            | 2350 mm            | 2350 mm            |
| Volume              | 7.6 m <sup>3</sup> | 7.6 m <sup>3</sup> | 7.6 m <sup>3</sup> |

**MOFFAT®**

**Australia**

Moffat Pty Limited  
**Victoria/Tasmania**  
740 Springvale Road  
Mulgrave, Victoria 3170  
Telephone 03-9518 3888  
Facsimile 03-9518 3833  
vsales@moffat.com.au

**New South Wales**

Telephone 02-8833 4111  
nswsales@moffat.com.au

**South Australia**

Telephone 03-9518 3888  
vsales@moffat.com.au

**Queensland**

Telephone 07-3630 8600  
qldsales@moffat.com.au

**Western Australia**

Telephone 08-9413 2400  
wasales@moffat.com.au

**New Zealand**

Moffat Pty Limited

**Rolleston**

45 Illinois Drive  
Izone Business Hub  
Rolleston 7675  
Telephone 03-389 660  
Facsimile 03-389 6660  
sales@moffat.co.nz

**Auckland**

Telephone 09 -574 3150  
sales@moffat.co.nz

Important Notice:  
This spec sheet is meant for commercial purpose only. For technical documentation please refer to our service manuals.



ISO9001  
Quality Management Standard



In line with policy to continually develop and improve its products, Moffat Limited reserves the right to change specifications and design without notice.

