

## IBC Immersion Heater for Bottle-in-Cage

When speed is required and product can readily accept heat without damaging, direct application of heat to the contents of an Intermediate Bulk Container (IBC) is worth serious consideration. SBH Solutions has recognised this need and developed a powerful self-supporting IBC immersion heater. The standard heaters produce a concentrated 2400w or 3000w and are equipped with a 0 – 120°C thermostat which sits on a stainless-steel plate on top of the inlet, well away from the heat generating element. In winter conditions it will achieve temperatures up to 30 - 40°C across the mass of an IBC over time (dependent upon ambient), and higher temperatures if used in combination with an insulation only heater jacket to prevent energy dissipation to the surrounding environment.

Available as standard for water based and non-corrosive products, it can be manufactured for some other solutions dependent upon presentation of a relevant MSDS.

### Specifications

2400W with 10-amp, or 3000W with 15-amp single phase plug on 1.5m earthed lead. 240 Volt maximum 50/60Hz A.C. Standard element is Incolloy 800; other elements available.  
Overall Dimensions: 965mm x 170mm  
Length of Coil and element support in IBC: 850mm (heating coil bottom 180mm)  
Maximum width of coil: 130mm  
Width of support plate: 170mm (suits 150mm opening)  
Weight 4kg



### Features and Benefits

- Fastest means of heating product in an IBC allows productivity to be achieved without needing to plan very far ahead (as long as product does not damage with direct application of heat).
- Heat is concentrated at the bottom of the IBC so that natural convection will transfer the heat outwards and upwards while allowing early dispensing through the bottom discharge point.
- Use for local warming of viscous liquid product in winter or when combined with an insulation only IBC heater jacket, could raise temperatures to 40 - 50°C over time.
- Suitable for 150mm wide IBC filling points only.
- Elements can be manufactured to meet specific product needs (such as some corrosive products or lower power).



Interested and require more information? Please contact your local representative or email us at [info@sbhsolutions.com.au](mailto:info@sbhsolutions.com.au)

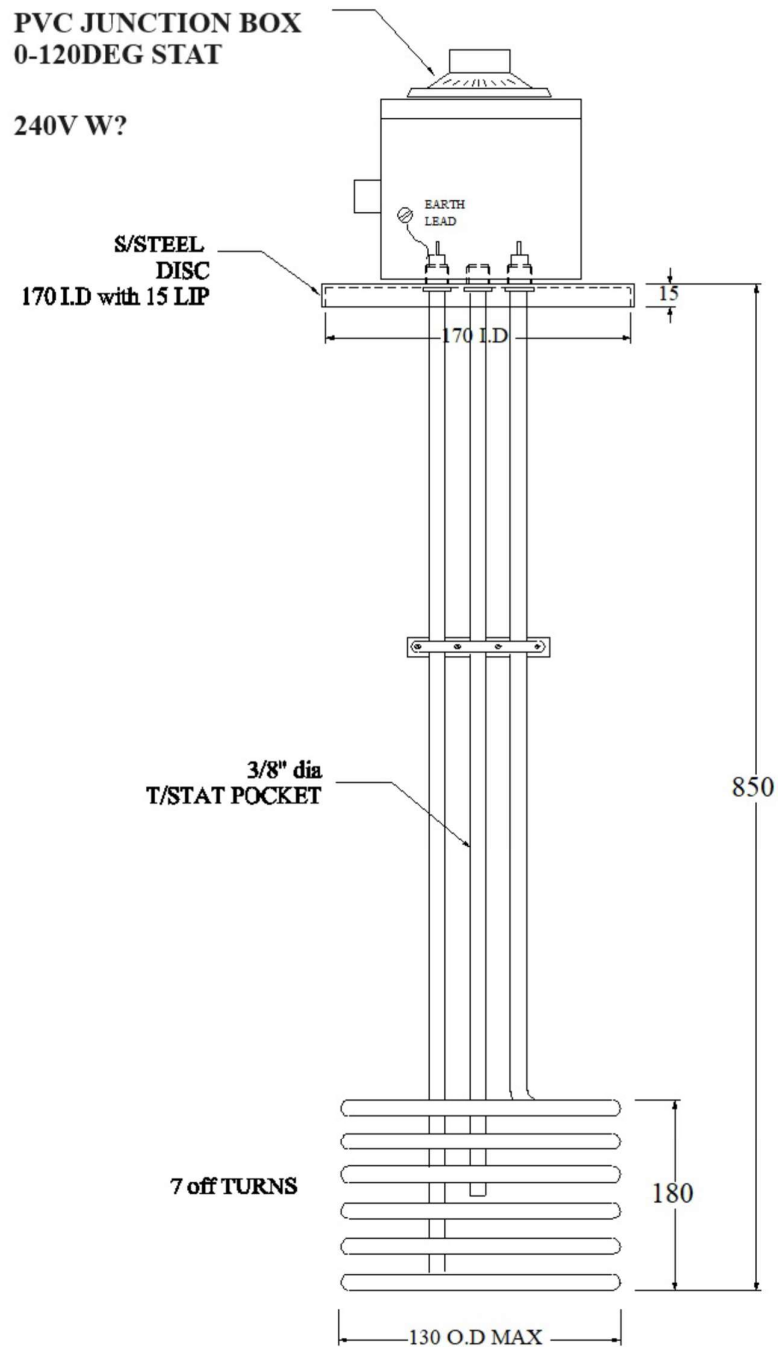

Interested and require more information? Please contact your local representative or email us at [info@sbhsolutions.com.au](mailto:info@sbhsolutions.com.au)