

TOURNUS EQUIPEMENT



ROLL'SERVICE

ROLL'SERVICE

HEATED TEMPERATURE HOLDING BANQUET TROLLEY

HOT LINK



Effective

Well designed

Hygienic

Practical

Non-marking shockproof surround

Ergonomic

Easy to load

Easy access to the adjustments

Easy handling

Compact

Fast rise in
temperature :
from +20 to +85°C
in 20 minutes

Heated temperature holding banquet trolley. Made of food quality stainless steel with rock wool insulated walls and door. Electronic control thermostat with digital display. Inside entirely radiused, with press-draw sliders and base. Space between sliders : 71 mm. Stainless steel or glazed door, with removable seal opens 270°. Carrying handles on sides and rear guide bar.

Non-marking, shock-proof surround, except for 5 levels model fitted with corner bumpers. 4 wheels 2 brakes, Ø 160 mm stainless steel cover on models 20 levels GN 2/1 models, Ø 125 mm polyamide cover on the models 10 and 15 levels GN 2/1 models, 10,15 and 20 levels GN 1/1, and Ø 80 mm stainless steel cover on the 5 levels model. Inodex of protection IP 25, for low pressure cleaning. NF-Hygiene Certified.

Electric heating system : heating provided by a centrifugal fan to the rear, with external motor which circulates air through sealed stainless steel heating elements. Stainless steel heating internal air deflection system. Regulated temperature at 85°C. The electronic regulation thermostat with digital display allows a regulation from 60 to 85°C. Features a fast rise in temperature feature, from 20 to 85°C in 20 minutes. Supplied with spiral cable and moulded plug for electrical connection, Voltage 230V, rate 50/60 Hz.

NEW :

- Condensate drip system (except for the 5 level Roll'Service)
- Door stay system : easier loading thanks to the new door stay system in open position.

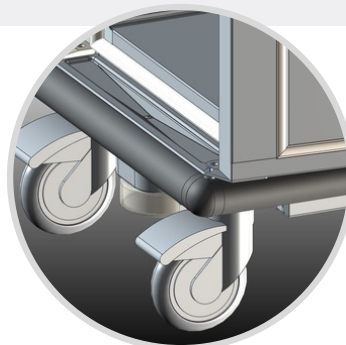

Embossed chute

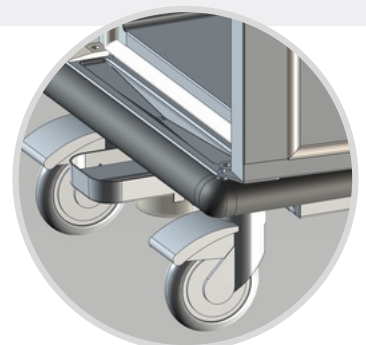

Removable and retractable
condensate drip-system

HOW MANY PANS?*

Stainless steel pans	Capacity (L)	Number of servings
GN 1/1 depth 55 mm	7,5	24-30 meats or 17-20 vegetables
GN 1/1 depth 65 mm	8,5	27-34 meats or 19-23 vegetables
GN 1/1 depth 100 mm	13	42-52 meats or 29-35 vegetables
GN 1/1 depth 150 mm	20	64-80 meats or 45-53 vegetables

* Average weight of a portion : meat 100 to 120g. Vegetables 150 to 180g.



Roll'Service with humidification control

The electronic control allows selection of 5 rates of hygrometry. Removable rotomoulded tank accessible from the front, with 2 litre capacity, allowing 24 hour operation.

Roll'Service GN 1/1

ROLL'SERVICE	Electrical consumption (kwh) (1)	Input power (kW) (2)	Capacity (L)	Overall dim. l x W x h (mm)	Reference
10 levels with s/steel door	0,290	0,825	146	528 x 821 x 1134	507336
15 levels with s/steel door	0,300	1,215	215	528 x 821 x 1489	507356
15 levels with glass door	0,300	1,215	215	528 x 821 x 1489	507357
20 levels with s/steel door	0,575	1,215	284	528 x 821 x 1844	507386
20 levels with glass door	0,575	1,215	284	528 x 821 x 1844	507387

Roll'Service GN 2/1

ROLL'SERVICE	Electrical consumption (kwh) (1)	Input power (kW) (2)	Capacity (L)	Overall dim. l x W x h (mm)	Reference
10 levels with s/steel door	0,41	1,215	285	733 x 941 x 1134	507436
15 levels with s/steel door	0,405	1,215	420	733 x 941 x 1489	507456
15 levels with glass door	0,405	1,215	420	733 x 941 x 1489	507457
20 levels with s/steel door	0,785	2,015	555	733 x 941 x 1880	507486
20 levels with glass door	0,785	2,015	555	733 x 941 x 1880	507487

(1) average electrical power consumption per service (as per NF 040 016 for a 3h30 cycle)

(2) maximum start up power required

Roll'Service without humidification

Roll'Service GN 1/1

ROLL'SERVICE	Electrical consumption (kwh) (1)	Input power (kW) (2)	Capacity (L)	Overall dim. l x W x h (mm)	Reference
5 levels with s/steel door	0,220	0,825	77	524 x 817 x 708	507301
10 levels with s/steel door	0,290	0,825	146	528 x 821 x 1134	507331
15 levels with s/steel door	0,300	1,215	215	528 x 821 x 1489	507351
15 levels with glass door	0,300	1,215	215	528 x 821 x 1489	507352
20 levels with s/steel door	0,575	1,215	284	528 x 821 x 1844	507381
20 levels with glass door	0,575	1,215	284	528 x 821 x 1844	507382

Roll'Service GN 2/1

ROLL'SERVICE	Electrical consumption (kwh) (1)	Input power (kW) (2)	Capacity (L)	Overall dim. l x W x h (mm)	Reference
10 levels with s/steel door	0,410	1,215	285	733 x 941 x 1134	507431
15 levels with s/steel door	0,405	1,215	420	733 x 941 x 1489	507451
15 levels with glass door	0,405	1,215	420	733 x 941 x 1489	507452
20 levels with s/steel door	0,785	2,015	555	733 x 941 x 1880	507481
20 levels with glass door	0,785	2,015	555	733 x 941 x 1880	507482

(1) correspond à la consommation électrique moyenne par service selon la norme NR 040-016 pour un cycle de 3h30.

(2) correspond à la puissance maximale lors du démarrage, qui dimensionne le raccordement électrique.

Discover our options !

Description	Reference
extra-cost for lock and key	701961
extra-cost for reverse opening door*	701963
extra-cost for 4 swivel stainless steel wheels Ø 125 mm including 2 brakes to replace wheels with polyamid cover	702190





ROLL'SERVICE

TEMPERATURE HOLDING BANQUET TROLLEY HOTLINK



Compact :
GN1/1 : 528 x 821 mm,
GN 2/1 : 733 x 941 mm.



Easy access to functions and settings :
temperature control (range from 60°C to 85°C),
hygrometry control (35% to 50%), IP25.



2 side handles and one bar at rear for easy handling.



Ergonomic : exclusive modern, oversized handle.



Non-marking shockproof surround : protection of the cabinet and its surrounding.



Easy handling : 4 swivel wheels, 2 with brakes.

**TOURNUS
EQUIPEMENT**

TOURNUS EQUIPEMENT - 25 Avenue Jean Moulin - F71700 TOURNUS
Tél : + 33 385 274 265 - www.tournus.com



Easy loading : 270° door opening.
New : door stay system : easier loading

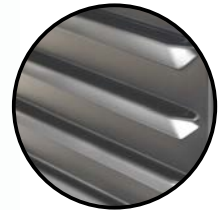

Hygienic : curved surfaces and press-drawn sliders. Space between sliders : 71 mm.



Optimum temperature distribution : centrifugal fan.



Easy operation : removable, 2 litre tank, front access. 24 hour autonomy.



Maintenance : easy access to technical parts.



NEW
Condensate drip system
(not available for 5 level model)