

42030 V6Z

160 LB. (72KG) CAPACITY
RIGID-MOUNT WASHER-EXTRACTOR

SPECIFICATION SHEET

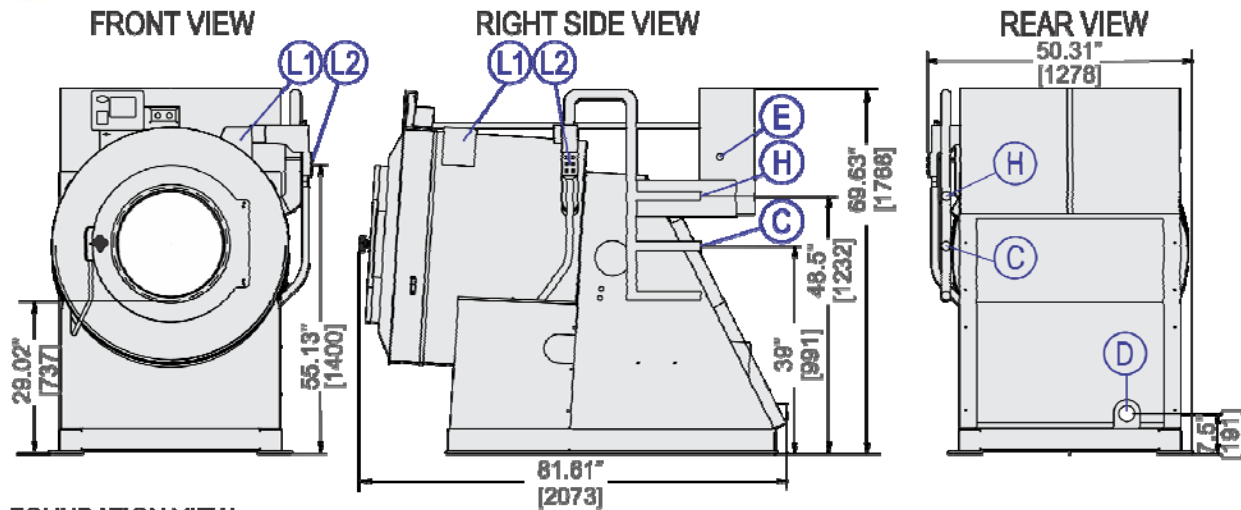

ANCHORING DETAIL

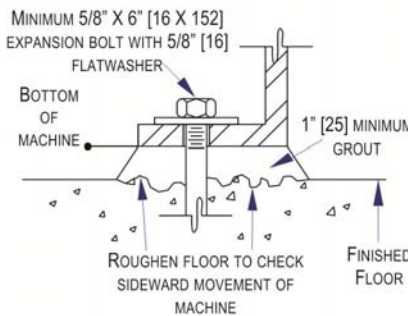

FLOOR REQUIREMENT 12" MINIMUM
RECOMMENDED ▼, ◆, ■

LEGEND

C	Cold water inlet, 1.25" (32 mm) NPT
D	Drain to rear, 3" (76 mm) pipe socket joint
E	Main electrical connection
F	Foundation Pads; anchor bolt holes .8125" (21 mm) diameter
H	Hot water inlet, 1.25" (32 mm) NPT
L1	Standard soap chute
L2	Liquid supply inlets

MECHANICAL SPECIFICATIONS

Capacity – lb. (kg)	160 (72)
Cylinder Diameter x Depth – in. (mm)	42 x 30 (1067 x 762)
Cylinder Volume – cu. ft. (L)	24 (679)
Door Opening – in. (mm)	21.69 (551)
Machine Dimensions (W x D x H) – in. (mm)	50.31 x 81.61 x 69.63 (1278x2073x1768)
Shipping Dimensions (W x D x H) – in. (mm)	86 x 60 x 76 (2184 x 1524 x 1930)
Motor – HP (kW)	15 (11.18)
Wash Speeds – RPM	25-41
Distribution Speed – RPM	60
Extraction Speeds – RPM	200-710
Extraction G-Force	300
Static Weight – lb. (kg) ◆	3,603 (1634)
Max. Dynamic Load RMS – lb. (kg) ◆	5,916 (2683)
Frequency (Hz)	10
Water Pressure <i>(Required)</i> – psi (bar)	10-75 (.68–5.1)
Water Valve CV Rating	12.9 (49)
Minimum Recommended Distance Between Machines – in. (mm)	12 (305)

ELECTRICAL SPECIFICATIONS

Voltage	Running Amps	Fuse (Amps)	Circuit Breaker (Amps)
208/3/60	40	FRN50	50
220/3/50-60	38	FRN50	50
240/3/60	35	FRN50	50
380/3/50-60	23	FRS30	30
415/3/50	21	FRS25	25
480/3/60	19	FRS25	25

See Fuse and Wire Size manual MAEFUSE 1BE for safety information. Contact factory for electrical specifications if equipped with Electric Heat option. Contact factory for single phase availability.

▼ See dimensional drawing for complete details.

◆ The floor and/or other support components must have sufficient strength (and rigidity with due consideration for natural or resonant frequency thereof) to withstand the fully loaded weight of the machine including the goods, the water, and any repeated sinusoidal (rotating) forces generated during its operation. Contact the factory for additional machine data for use by a competent soil and/or structural engineer.

■ Machine bases made from concrete should either be part of a monolithic pour or should be tied into foundation and not isolated from existing floor.



42030 V6Z

160 LB. (72 KG) CAPACITY
RIGID-MOUNT WASHER-EXTRACTOR

SPECIFICATION SHEET

Standard Features:

- RinSave® water saving technology
- 7 speeds (2 wash, 1 distribution, 1 RinSave, 3 extract)
- MilTouch™ programmable control
- Single-motor inverter drive
- Tall, lifting ribs
- Tapered roller bearings
- High M.A.F. (Mechanical Action Factor)
- Large cylinder perforations
- Fresh-water flushing chemical manifold
- Auto tension V-belt drive
- Six (6) liquid chemical injection ports
- Control is configurable to display your choice of language
- 5-year limited warranty on frame, cylinder & shell



Optional Features:

- Steam
- Electric Heat
- 5 compartment flushing supply injector
- Prison package
- Air operated reuse inlet, additional electrically operated reuse drain

Why Purchase Milnor?

- RinSave® water saver in conjunction with large cylinder perforations provides more efficient rinsing. **BENEFIT: Saves water, energy, and time.**
- Larger cylinder volume than most competitive similar sized washer-extractors provides *greater productivity*. More linen washed per day, or fewer hours required to process. **BENEFIT: Saves labor.**
- Faster process times reduce fabric wear, promoting *longer linen life!* **BENEFIT: Saves linen replacement costs.**
- Tall perforated ribs provide excellent lift and high drop. **BENEFIT: Greater mechanical action (M.A.F.) leads to better wash quality.**
- 300-G high extract provides excellent moisture removal. Lower extract speeds are available for uniforms, delicate textiles and blended fabrics. **BENEFIT: Better extraction saves dryer fuel.**
- MilTouch™ touch screen control, utilizing resistive touch screen technology and full VGA resolution, has a clear and informative display which shows current machine status info including total formula time and time elapsed. Formulas can be developed on a PC, saved to USB external memory and uploaded with a screen touch. Controller also provides intuitive fault diagnosis and relevant troubleshooting suggestions. **BENEFIT: Fewer operator errors.**
- Superior product support through local, highly-skilled dealers. **BENEFIT: Faster repairs mean less downtime.**



Superior cylinder design



Safe chemical injection

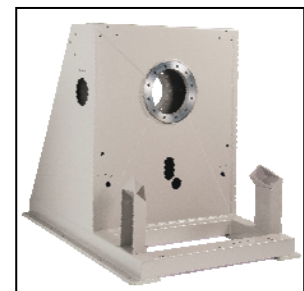

Solid, industrial frame

Contact Milnor for your local, authorized dealer:

Pellerin Milnor Corporation
P.O. Box 400 • Kenner, LA 70063
t: 504-467-9591 • f: 504-468-3094

