

Carton Sealing Machine

#61300



The Automatic Carton Sealing Machine, is designed for industrial and warehouse applications. This robust machine is engineered to streamline carton sealing, enhancing efficiency and productivity. With the ability to simultaneously seal the top and bottom of cartons at a rapid pace, it ensures a smooth and efficient packaging process.

Highlights

- Processes 30 cartons per minute
- Swift tape application for various sizes
- Adjustable height feature
- Double Motors, Side-Drive Belts
- Handles heaviest cartons efficiently
- Ensures reliable operation
- Sturdy, Heavy-Duty Design
- Powder-coated finish enhances durability

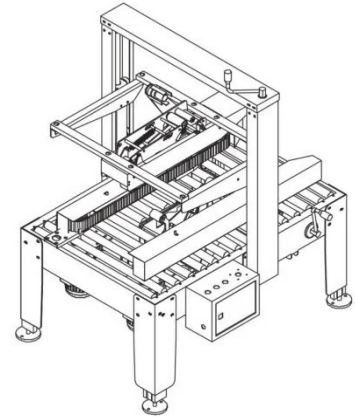

Features

- **Enhanced Mobility:** Caster wheels for easy movement
- **Versatile Dispensers:** Interchangeable top and bottom dispensers
- **Safety Features:**
 - Adjustable tape overlap length
 - Blade guards for safety
- **Technologically Advanced Operation:** Precise and advanced functionality
- **Time-Saving and Productive:** Boosts productivity, saves time
- **Neat Carton Sealing:** Ensures efficient and tidy sealing

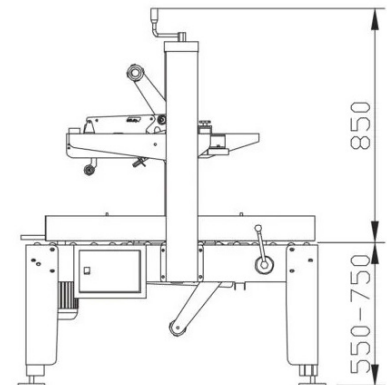

Specifications

Drive Type	Side Belt Drive
Power Supply	220V/50Hz, 400W
Carton Size	L (130mm-no limit) W(120-480mm) H(120-480mm)
Tape Size	48-60mm machine roll
Sealing Speed	30 cartons/min
Work Table Height	550-700mm
Dimensions	L 1160mm x W 886mm x H 1585mm
Gross Weight	140kg

