

# Rotisol



 BASKET RÔTISSERIE

## Rôti-Roaster FBP5.520

### DESIGN

- High Performance, Elegant and modern rotisserie with interior lighting to accentuate your roasting meats and vegetables
- All Stainless Steel body
- Optional: double convex glazing anti-burns with illuminated sign "ROTISSERIE"

### CULINARY ADVANTAGES

- Rapid roasting whilst still retaining rotisserie quality
- Display and programming of cooking time and temperature
- 6 cooking programs, alert at end of cycle - products can then be maintain at 63 C°
- Latest range of heating elements
- 5 chicken baskets engineered for easy unloading
- Also suitable for other poultry, meats and vegetables

### SAFETY

- K.Glass door reduces heat loss, hence quicker cooking times and prevents burns and burns
- Automatic cooling of the heating turbine at end of cooking cycle
- Drip pan with a plug to collect grease for ensured hygiene and safety
- New generation of rotisserie with very low energy consumption, fully insulated model



Option : double convex glazing anti-burns



### CLEANING

- Removable inside panel and juice tray for easy cleaning
- Protection of the interior lighting by ceramic glass for easy surface cleaning
- Disassembly of all cooking accessories for simple cleaning

### ACCESSORIES





Front view

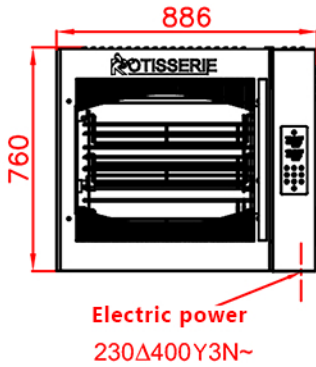

Side view

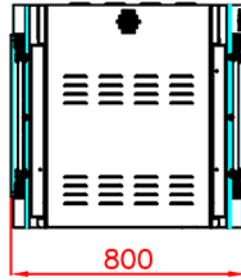

Top view

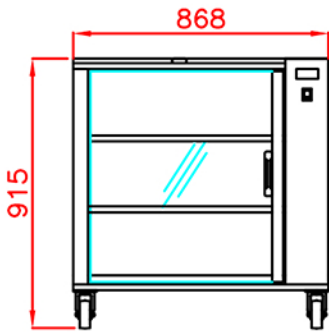
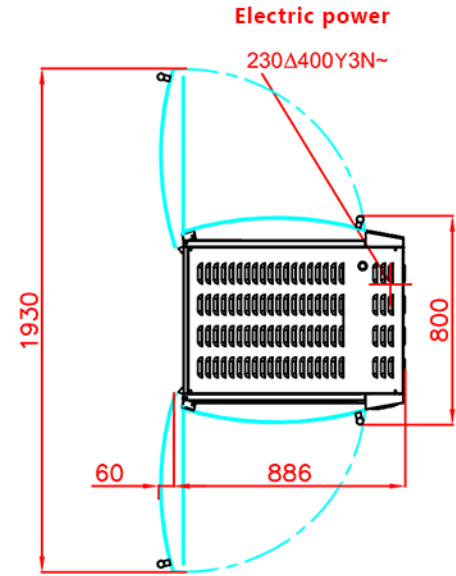

Heated base cabinet  
1055 W

(Option)

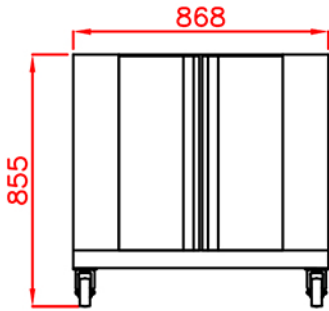
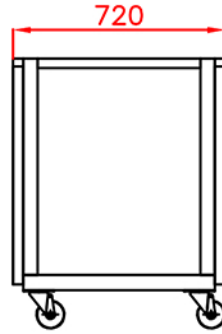

Supporting cupboard

(Option)

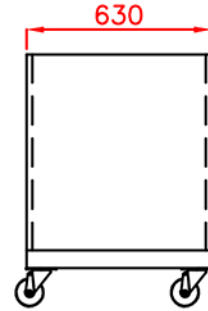

Option : Band with illuminated sign

## STANDARD FIXTURES

- STD FINISH : Stainless Steel
- 5 chicken Baskets
- 2 tempered glass doors (K.Glass)
- Drip pan
- Protectives parables steel removable

## SPECIFICATIONS

<b>Electricity</b>	4.9 KW tri / 400 VOLTS - 3 phase / 50-60 HERTZ
<b>Capacity</b>	15/20 CHICKENS
<b>Warranty</b>	1 year
<b>Venting</b>	Hood installed conformly with all local codes
<b>Minimum clearance</b>	65 mm on the right, left and rear side

