



PANEL SAW

Diamond 300 Series

# Instruction Manual

## IMPORTANT

For your safety, read instructions carefully before assembling or using this product. Save this manual for future reference.



Original Instruction  
V.10-201705

**JACCRA INDUSTRIES**

**Imported by Jacra Industries Pty Ltd**  
23 Exhibition Drive, Malaga Western Australia

**Sales + Support**  
[www.jaccraindustries.com](http://www.jaccraindustries.com)

### HEALTH AND SAFETY GUIDELINES

Always follow the instructions provided with the manual. Always wear safety glasses when using woodworking equipment. Always disconnect the power before adjusting any equipment. Failure to observe proper safety procedures and guidelines can result in serious injury.

**WARNING:** Do not allow familiarity (gained from frequent use of your machine and accessories) to become commonplace. Always remember that a careless fraction of a second is sufficient to inflict severe injury.



Always wear safety glasses when using woodworking equipment.



Always read the instructions provided before using woodworking equipment.

# INDEX

- 1 GENERAL INFORMATION
  - 1.1 FOREWORD
  - 1.2 MACHINE IDENTIFICATION
  - 1.3 CUSTOMER SERVICE RECOMMENDATIONS
  
- 2 SAFETY PRECAUTIONS
  - 2.1 SAFETY REGULATIONS
  - 2.2 RESIDUAL RISKS
  - 2.3 SAFETY AND INFORMATION SIGNALS
  
- 3 SPECIFICATIONS
  - 3.1 MAIN COMPONENTS
  - 3.2 TECHNICAL SPECIFICATION
  - 3.3 ELECTRICAL CONNECTION
  - 3.4 NOISE LEVEL
  - 3.5 DUST EXTRACTION
  - 3.6 SAFETY DEVICES
  
- 4 INSTALLATION
  - 4.1 CONTENTS OF PACKAGE
  - 4.2 LIFTING AND UNLOADING
  - 4.3 INSTALLATION ZONE CHARACTERISTIC
  - 4.4 INSTALL OF LOOSE PARTS - INTRODUCTION
  
- 5 ADJUSTMENT
  - 5.1 SCORER ADJUSTMENT
  - 5.2 EXTENSION TABLE FLATNESS ADJUSTMENT
  - 5.3 RIP FENCE PRECISION ADJUSTMENT
  
- 6 OPERATING PROCEDURES
  - 6.1 MACHINE START AND STOP
  - 6.2 WORKING STATION
  - 6.3 WORKING WITH THE MACHINE
  - 6.4 CORRECT USE FOR THIS MACHINE
  
- 7 MAINTENANCE
  - 7.1 REPACE SAW BLADE
  - 7.2 OVERALL CLEANING
  - 7.3 GENERAL LUBRICATION
  - 7.4 REPLACEMENT AND DISPOSAL
  
- 8 TROUBLE SHOOTING
  
- 9 DIAGRAMS AND COMPONENTS

# 1. GENERAL INFORMATION

## 1.1 FOREWORD

This machine is designed to make straight and angle cut for wood material, especially for wood board cutting.

Some information and illustrations in this manual may differ from the machine in your possession, since all the configurations inherent in the machine complete with all the optionals are described and illustrated. Therefore, refer only to that information strictly connected with the machine configuration you have purchased.

With this manual we would like to provide the necessary information for maintenance and proper use of the machine. The distribution network is at your service for any technical problem, spare parts or any new requirement you may have for the development of your activity.

This manual must be read and understood before operating the machine. This will provide a better working knowledge of the machine, for increased safety and to obtain the best results.

To facilitate its reading, the manual has been divided into sections pointing out the most important operations. For a quick research of the topics, it is recommended to consult the index. To better stress the importance of some basic passages, they have been marked by some preceding symbols:



### **WARNING**

Indicates imminent risks which may cause serious injury to the operator or other persons. Be careful and scrupulously follow the instructions.



### **CAUTION**

A statement advising of the need to take care lest serious consequences result in harm to material items such as the asset or the product.

## 1.2 MACHINE IDENTIFICATION

There is an identification plate fixed to the machine, containing the manufacturer's data, year of construction, serial number and technical specifications.

## 1.3 CUSTOMER SERVICE RECOMMENDATIONS

Apply the machine to skilled and authorized technical staff to carry out any operation dealing with parts disassembly. Keep to the instructions contained in this manual for the correct use of the machine.



### **CAUTION**

Only skilled and authorized staff shall use and service the machine after reading this manual. Respect the accident prevention regulations and the general safety and industrial medicine rules.

# 2. SAFETY PRECAUTIONS

## 2.1 SAFETY REGULATIONS



### **WARNING**

Read carefully the operation and maintenance manual before starting, using, servicing and carrying out any other operation on the machine.

The manufacturer disclaims all responsibilities for damages to persons or things, which might be caused by any failure to comply with the safety regulations.

- The machine operator shall have all necessary prerequisites in order to operate a complex machinery.
- It is prohibited to use the machine when under the influence of alcohol, drugs or medication.
- All the operators must be suitably trained for use, adjustment and operation of the machine.
- The operators must carefully read the manual paying particular attention to the warning and safety notes. Furthermore, they must be informed on the dangers associated with use of the machine and the precautions to be taken, and must be instructed to periodically inspect the guards and safety devices.
- Before carrying out adjustment, repair or cleaning work, disconnect the machine from the electric power and lock the disconnect switch in its "OFF" position by setting the main switch to stop.
- After an initial bedding-in period or many hours of operation, the driving belts may slacken; this causes an increase in the tool stopping time (the stopping time must be less than 10 seconds). Immediately tighten them.
- The working area around the machine must be kept always clean and clear, in order to have an immediate and easy access to the switchboard.
- Never insert materials which are different from those which are prescribed for the machine utilization. The material to be machined must not contain any metal parts.
- Never machine pieces which may be too small or too wide with respect to the machine capacity.
- Do not work wood which has evident defects (cracks, knots, metal parts, etc.)
- Never place hands among the moving parts and/or materials.
- Keep hands clear from the tool; feed the piece with the aid of a pusher.
- Keep the tools tidy and far away from those not authorized persons.
- Never employ cracked nor unbalanced, neither not correctly ground tools.
- Never use the tools beyond the speed limit recommended by the producers.
- Carefully clean the rest surfaces of tools and make sure that they find perfectly horizontally positioned, and with no dents at all.
- Always wear gauntlets when handling the tools.
- Mount the tools in the right machining direction.
- Never start the machine before having correctly installed all the protections.
- Connect the dust suction hoods to an adequate suction system; suction must always be activated when the machine is switched on.
- Never open doors or protections when the machine or the system is operating.
- Many unpleasant experiences have shown that anybody may wear objects which could cause serious accidents. Therefore, before starting working, take any bracelet, watch or ring off.
- Button the working garment sleeve well around the wrists.
- Take any garment off which, by hanging out, may get tangled in the MOVING UNITS.
- Always wear strong working footwear, as prescribed by the accident-prevention regulations of all countries.
- Use protection glasses. Use appropriate hearing protection systems (headsets, earplugs, etc.) and dust protection masks.
- Never let unauthorized people repair, service or operate the machine.
- The manufacturer is not responsible for any damage deriving from arbitrary modifications made to the machine.
- Any transport, assembly and dismantling is to be made only by trained staff, who shall have specific skill for the specified operation.
- The operator must never leave the machine unattended during operation.
- During any working cycle break, switch the machine off.
- In case of long working cycle breaks, disconnect the general power supply.
- The operating method to be followed in the event of accident or breakdown, the machine should be turned off immediately and unplug from main power and ask for assistance for the authorized people. If a blockage is likely to occur, the workpiece should be moved back a little and enable the equipment to be safely unblocked.

## 2.2 RESIDUAL RISKS

Despite observance of all the safety regulations, and use according to the rules described in this manual, residual risks may still be present, among which the most recurring are:

- contact with tool
- contact with moving parts (belts, pulleys, etc..)
- recoil of the piece or part of it
- accidents due to wood splinters or fragments
- tool insert ejection
- electrocution from contact with live parts
- danger due to incorrect tool installation
- inverse tool rotation due to incorrect electrical connection
- danger due to dust inhalation in case of working without vacuum cleaner.

Bear in mind that the use of any machine tool carries risks.

Use the appropriate care and concentration for any type of machining (also the most simple).

**The highest safety is in your hands.**

## 2.3 SAFETY AND INFORMATION SIGNALS

This signals may be applied on the machine; in some cases they indicate possible danger conditions, in others they serve as indication.

Always take the utmost care.

### SAFETY SIGNALS:



Risk of eye injury. Wear eye protection.



Wear hearing protection systems.



Danger of electric shock. Do not access the area when the machine is powered.



Carefully read and understand the manual before using the machine.

### INFORMATION SIGNALS:

Indicate the technical characteristics, direction of rotation and inclination, block and release, etc.

Carefully following the directions to simplify the use and adjustment of the machine.

The signals are graphically described and do not require further explanation.

# 3. SPECIFICATIONS

## 3.1 MAIN COMPONENTS

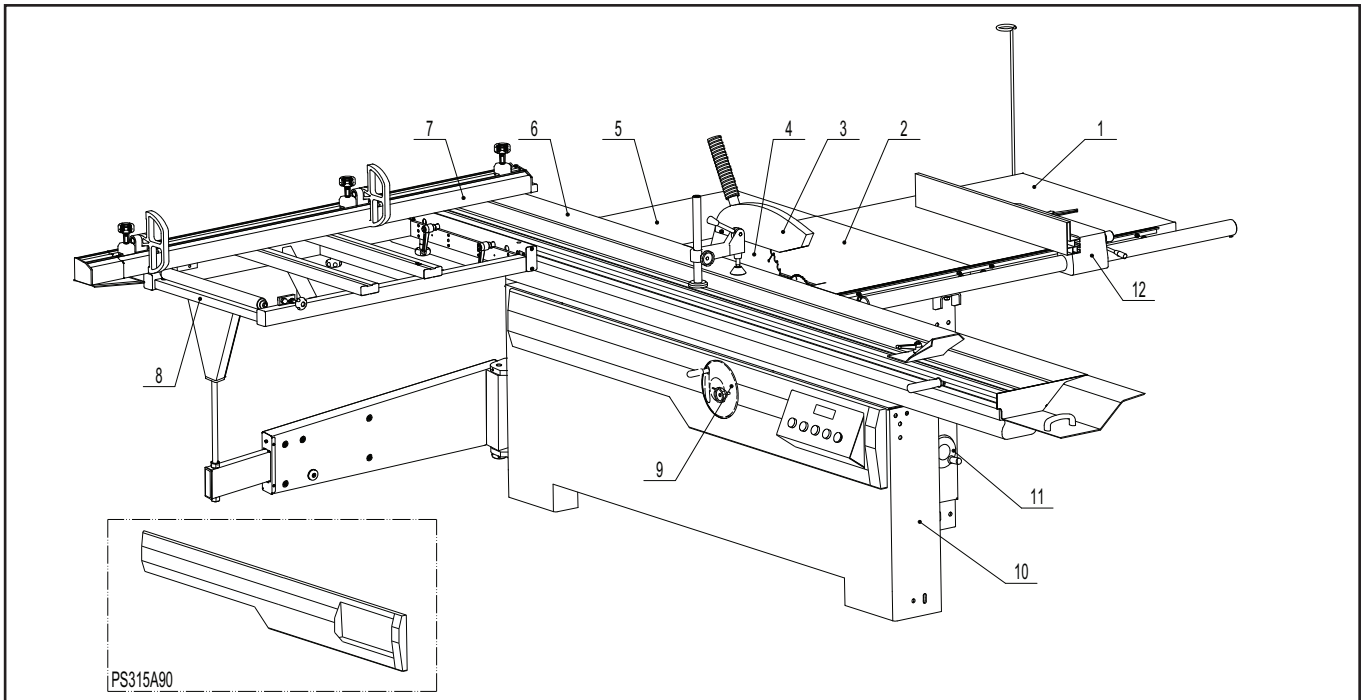

- 1 - Right extension table
- 2 - Main table
- 3 - Blade guard assembly
- 4 - Blade
- 5 - Rear extension table
- 6 - Sliding table
- 7 - Telescopic fence
- 8 - Square sliding table

- 9 - Tilting handwheel
- 10 - Lifting handwheel
- 11 - Frame assembly
- 12 - Rip fence assembly

## 3.2 TECHNICAL SPECIFICATION

SPECIFICATION		
Motor Voltage	230V/50Hz	3~400V/50Hz
Main motor power	3.0kW,S1	4.0kW,S1
Scoring motor power	550W,S1	550W,S1
Main blade diameter	315mm	315mm
Main blade speed	4000rpm	4000rpm
Scoring blade diameter	120mm	120mm
Scoring blade speed	8000rpm	8000rpm
Blade tilt	0~45°	0~45°
Main table size	800x530mm	800x530mm
Right extension table size	800x470mm/800x820mm	
Max.rip capacity	900/1250mm	
Max.depth of cut	96mm@90°,68mm@45°	
Sliding table size	1700x360mm/2200x360mm/2600x360mm/3200x360mm/2800x375mm/3200x375mm	
Sliding table stroke	1600mm/2100mm/2500mm/2700mm/3100mm	
Square sliding table size	1200x630mm	

### 3.3 ELECTRICAL CONNECTION

- Electrical installation should be carried out by competent, qualified personnel.
- The mains connection should be made using the terminal box.
- Replacement of the power supply cable should only be done by a qualified electrician.
- Connect the main leads to a standard 400V±10% for PS315-B/PS315X-B and 230V±10% for PS315/PS315X (50Hz+1%Hz) electrical supply which has protection devices of under-voltage, over-voltage, over-current as well as a residual current device (RCD) which maximum residual current rated at 0.03A, the main connection must have maximum 16A time-lag fuse for PS315/PS315X and 6A for PS315-B/PS315X-B. The test specified in 18.2 of EN 60204-1:2006 should be performed by end user after final installation.



#### WARNING

To avoid electrocution or fire, any maintenance or repair to electrical system should be done only by qualified electricians using genuine replacement parts.

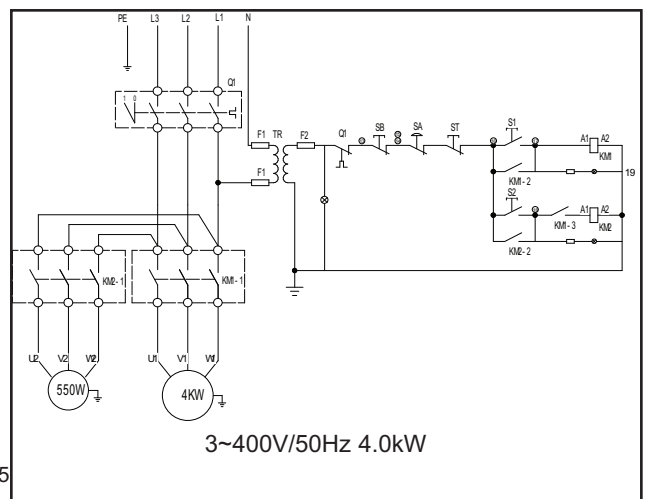
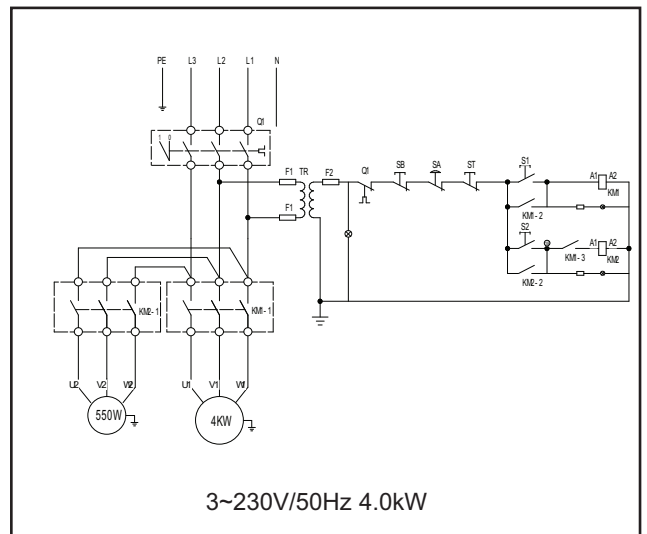
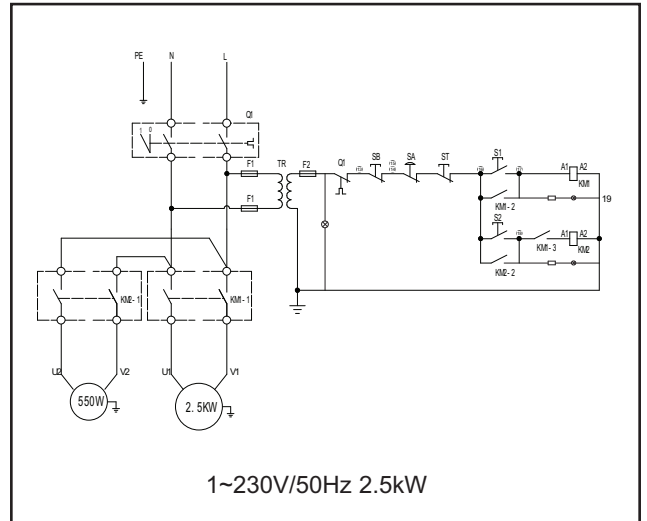

### 3.4 NOISE LEVEL

	No load	Load
Sound Pressure Level	< 80.4dB(A)	< 85.7dB(A)
Sound Power Level	< 98.1dB(A)	< 100.7dB(A)

Associated uncertainty K=4dB

Measurement made in accordance with EN ISO 3746:1995 and EN ISO 11202:1995

The noise levels measured are emission levels and not necessarily the safe working level. Although there is a correlation between the emission levels and the exposure levels, this cannot be used reliably to determine whether or not further precautions are required. The factors which affect the actual level of operator exposure include the duration of exposure, the ambient characteristics and other sources of emission, for example, the number of machines and other adjacent machining. The permitted exposure values may also vary from country to country. Nevertheless, this information allows the user of the machine to better evaluate the dangers and risks.

Other factors which reduce exposure to noise are:

- correct tool choice
- tool and machine maintenance
- use of hearing protection systems (e.g. headsets, earplugs,...)



**WARNING** Please always use the hearing protection systems.

### 3.5 DUST EXTRACTION

Proper suction eliminates the risks of dust inhalation and aids better functioning of the machine. The tables list the minimum air flow and speed values referenced to each single suction operation. The related pressure drop at the dust port is 530Pa.

Saw	
Upper hood	Lower hood
Air flow 140 cu.m/h	690 cu.m/h
Minimum air speed 20 m/s	

Ensure that the suction system guarantees these values at the hood-mouth connection point. (Fig.3.5)

Suction mouth diameter:

A - Blade guard .....  $\varnothing 40$  mm

B - Body dust suction .....  $\varnothing 100$  mm

Connect the mouths to the suction system with flexible tubes of adequate diameter. Tighten with clamps. The tube must be positioned in such a way so as not to obstruct the operator during machining.

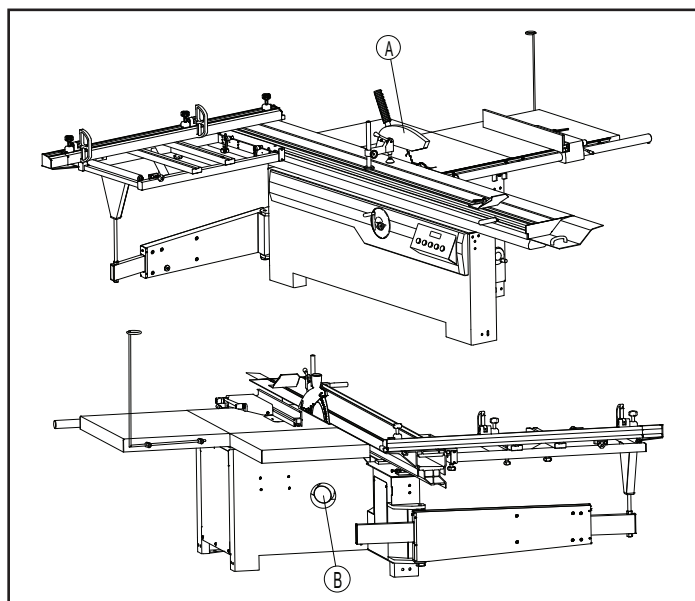

Fig.3.5



**WARNING**

Always work with the suction system on. Always start the suction system and the machine at the same time.

### 3.6 SAFETY DEVICES

The machine is equipped with the following safety devices: (Fig.3.6)

A - Safety Switch.

Stops the machine if the guard D is opened to perform operations on the blade.

B - Saw blade guard

Emergency Switch

When the button is pressed, the power will be cut immediately. It is a mechanical-operated push-button. Reset this button by turning it clockwise.

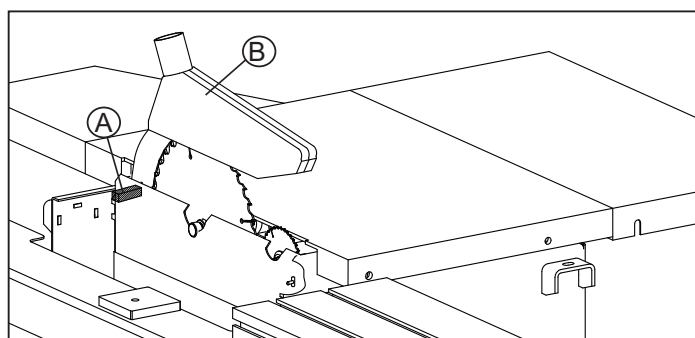

Fig.3.6

# 4. INSTALLATION



## CAUTION

Assembly need to be done by an experienced and trained person.

### 4.1 CONTENTS OF PACKAGE

- The machine is supplied partly assembled. Prior to use, further assembly is required.
- When unpacking the machine the following components are included for the initial assembly.
- If any parts are missing, do not attempt to assemble the machine; plug in the power cord, or turn the switch on until the missing parts are obtained and properly installed.

PS315/PS315X, Total two carton:

- 1 - Blade guard assembly
- 2 - Rear extension table
- 3 - Square sliding table
- 4 - Telescopic fence assembly
- 5 - Frame assembly
- 6 - Guide rail
- 7 - Scale bracket
- 8 - Rip fence assembly
- 9 - Right extension table
- 10 - Hose support rod
- 11 - Slide table(PS315X)

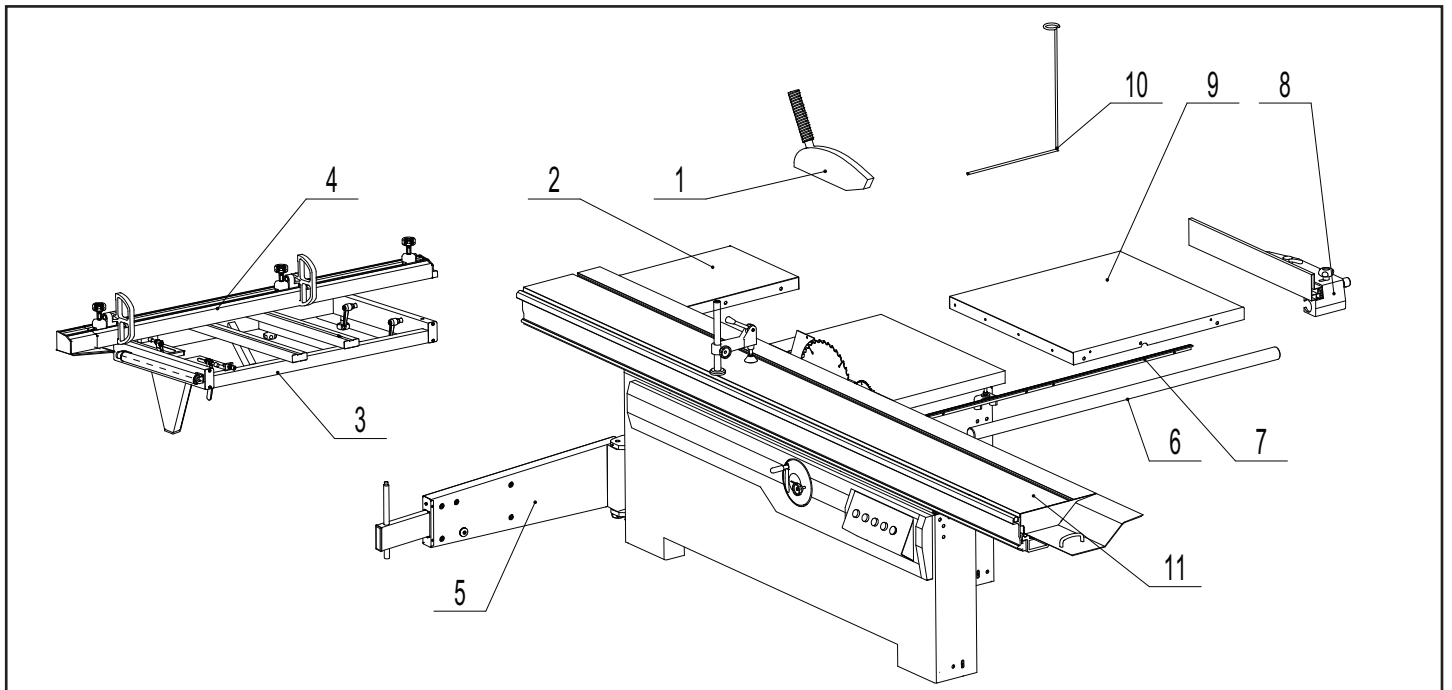

Fig.4.1

### 4.2 LIFTING AND UNLOADING



## WARNING

Lifting and handing should only be carried out by skilled personel specially trained to execute this kind of operations. During loading and unloading, avoid knocks to prevent damages to persons and things. Make sure no one is standing under the overhung load and/or within the bridge crane working range during machine lifting and handing.

Lifting may be carried out by bridge crane or self-propelled lift truck. Before starting the manoeuvres, free the machine of all the parts used for transport or Packaging that have remained on the machine. Check that the capacity of the lifting equipment is adequate for the gross weight of the machine indicated Fig.4.2.

If hoisting is carried out with a lift truck, proceed as follows:

- adjust the width of the forks A to 550 mm
- Insert forks A as in the figure in correspondence to name plates E ensuring that these are wedged against the back of the rear feet D.

If a bridge crane or a crane is available, proceed as follows:

- provide two slings B of suitable length and capacity (Belts minimum length 4000mm)
- lift the slings and position them as is shown in the Fig.4.2
- fasten the slings to the bridge crane C having adequate lifting power
- move the bridge crane by small steps to allow the slings B to settle, until optimum stability conditions are reached
- lift carefully and slowly, without causing the load to swing, and place the machine in the selected setting
- remove the protective wax coat from all tables and unpainted surfaces, using kerosene or its derivative products. Do not use any solvent, petrol or gas oil, which might dull the paint or oxidate machine parts.

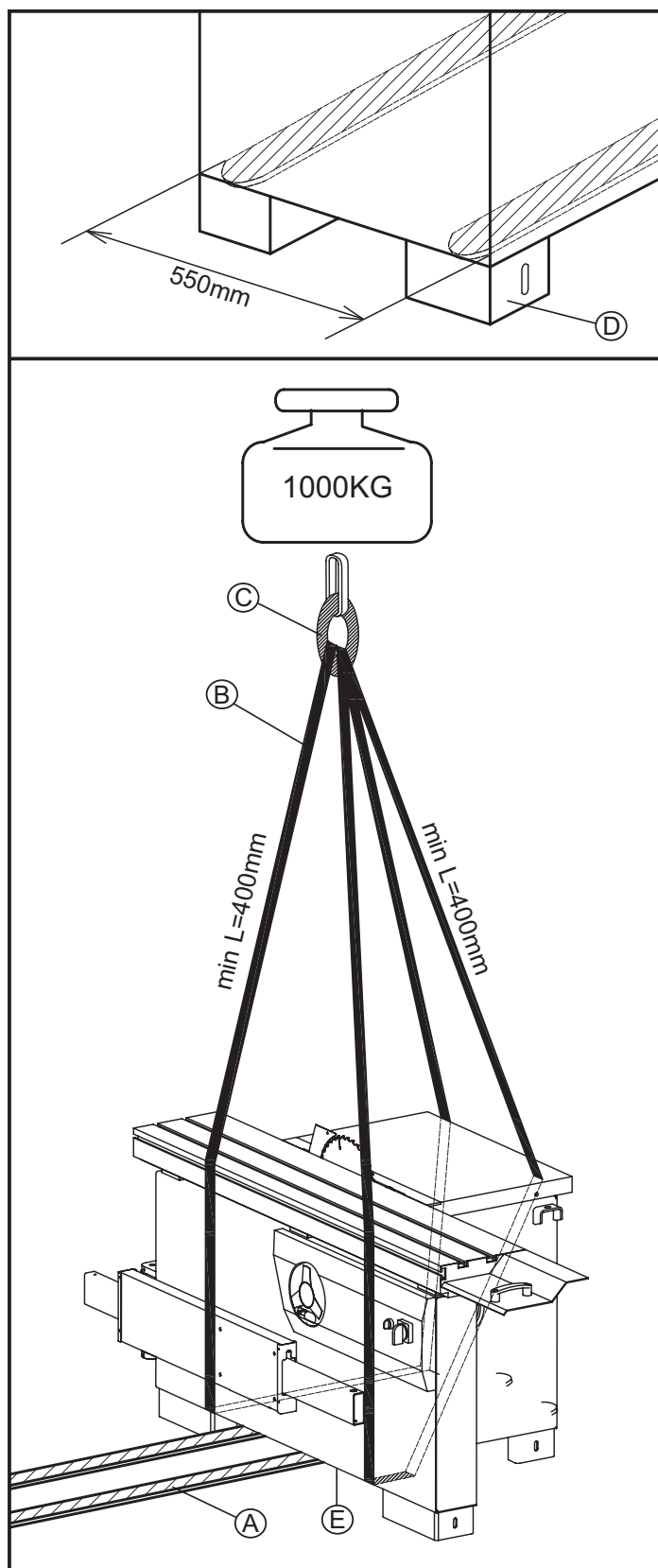

Fig.4.2

#### 4.3 INSTALLATION ZONE CHARACTERISTICS



#### WARNING

It is prohibited to install the machine in explosive environments.

The installation zone must be selected evaluating the work space required depending on the dimension of the pieces to be machined, and taking into account that a free space of at least 800 mm must be left around the machine. It is also necessary to check the floor capacity and its surface, so that the machine base is evenly resting on its four supports. A power outlet and a chip-suction system connection shall be close to the selected machine setting and it must be conveniently lighted (luminous intensity: 500 LUX).

## Fixing to the floor

The machine must be fixed to the floor.

- Use bolt / nut A to level the feet to ensure machine is well located.
- Put expansion bolts D (not supplied) into ground, use washer / lock washer C and hex nut B to fasten the bolts.

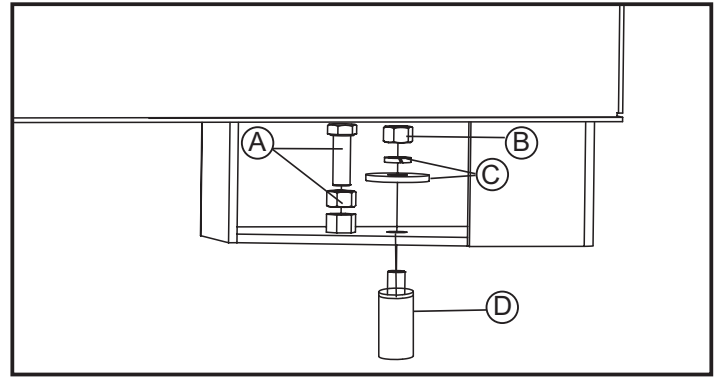

Fig.4.3

## 4.4 INSTALL OF LOOSE PARTS - INTRODUCTION

A few elements will be disassembled from the machine main structure due to packaging and shipping requirements. These loose parts should be installed as follows.



### WARNING

Please tighten all bolts and nuts absolutely. Otherwise, may cause machine wobble or serious injury to the operator or other persons.

### 4.4.1 INSTALL EXTENSION TABLE

Tools Required for Assembly:

- Wrench 16mm
- L Wrench 6mm
- Install Extension tables A to main table C with bolt 1 and washer 2.
- Install set screw 3 for micro-adjustment.

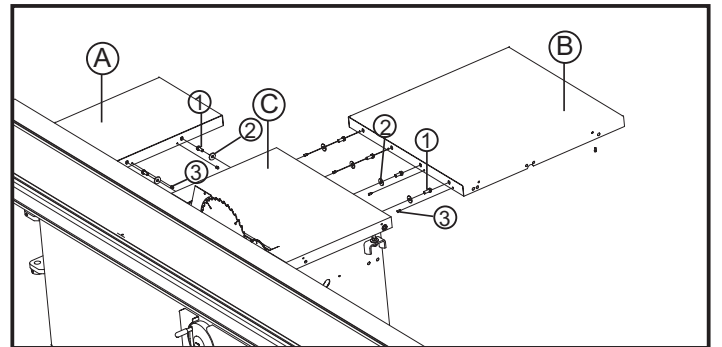

Fig.4.4.1

### 4.4.2 INSTALL BLADE GUARD AND HOSE SUPPORT ROD

Tools Required for Assembly:

- Wrench 13mm
- Philips screwdriver
- Install Blade guard A to Riving knife C with part 1 and 2.
- Install Hose support rod B to right extension table with part 3, 4, 5 and 6.

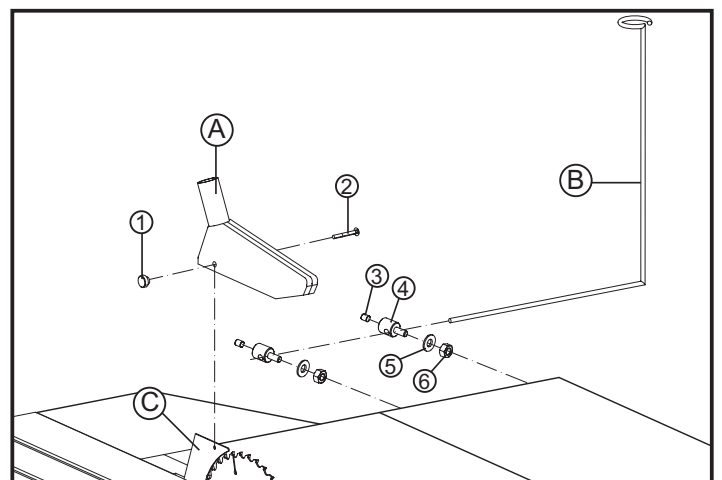

Fig.4.4.2

#### 4.4.3 INSTALL SQUARE SLIDING TABLE

- Put the square sliding table C into the slot of sliding table A.
- Put the support rod D into the hole of square sliding table C and the hole on support arm E.
- Lock the handle B.

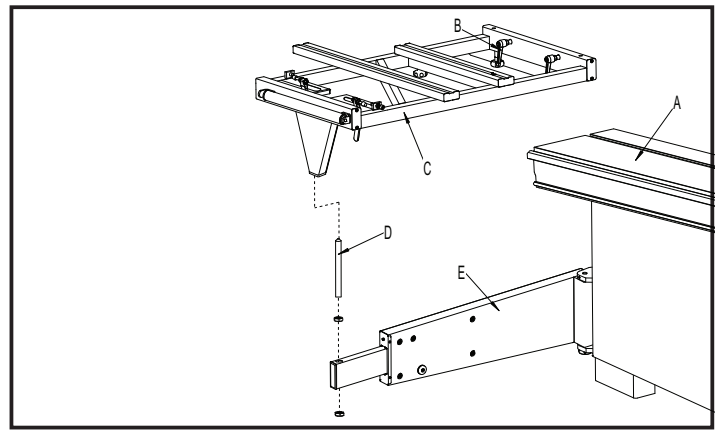

Fig.4.4.3

#### 4.4.4 INSTALL TELESCOPIC FENCE

- Put the pin A of telescopic fence into the hole which is on the square sliding table, and mount the handle B to the pin.
- Lock the knob C for stable tightening.
- The Knob D is designed to micro-adjust perpendicularity between telescopic fence and blade.

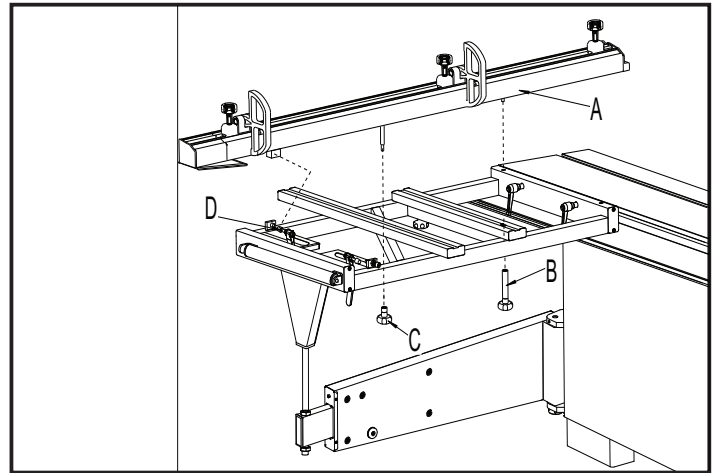

Fig.4.4.4

#### 4.4.5 INSTALL FENCE RAIL

Tools Required for Assembly:

- Wrench 18mm
- L Wrench 16mm

- Install scale seat B to tables with screw 1.
- Put the scale A into the slot of scale seat B.
- Install shaft 6 onto the guide rail C, and then mount the guide rail to tables with part 2, 3, 4, 5, 6 and 7.

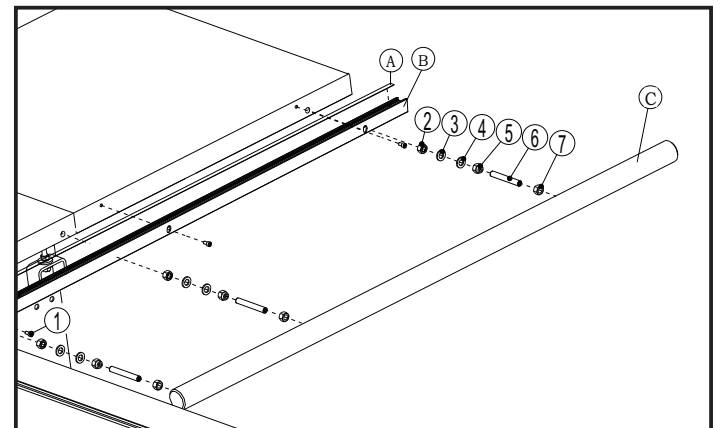

Fig.4.4.5

#### 4.4.6 INSTALL RIP FENCE

- Install the rip fence seat A to guide rail B as the picture shown.
- Install the screw C onto the guide rail B.
- Install the rip fence D to the fence seat A along its slot.

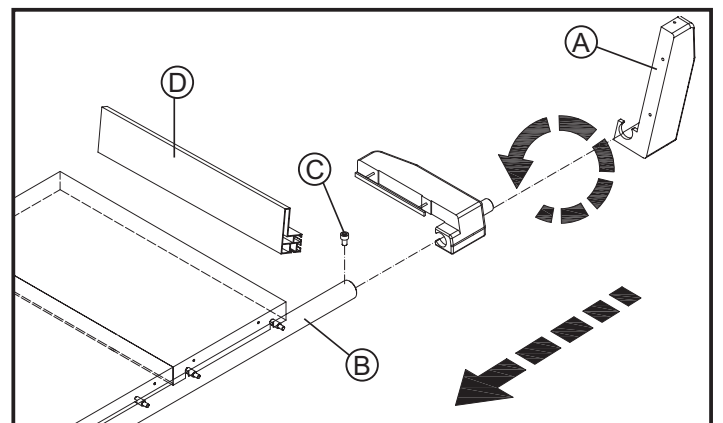

Fig.4.4.6

# 5. ADJUSTMENT



## WARNING

Handle the tools with protective gloves.

### 5.1 SCORER ADJUSTMENT



## CAUTION

For cutting panels coated with finishing material, you have to use the scorer D. Position the scoring saw blade in order to have an engraving equal to 1-1.5mm.

Proceed as follows if it is necessary to adjust scorer positioning with respect to the saw:

- Loosen the knob A, and then adjust scoring saw height using the knob C. Lock the knob A.
- Loosen the knob B, and then adjust scoring saw height using the knob D. Lock the knob B.

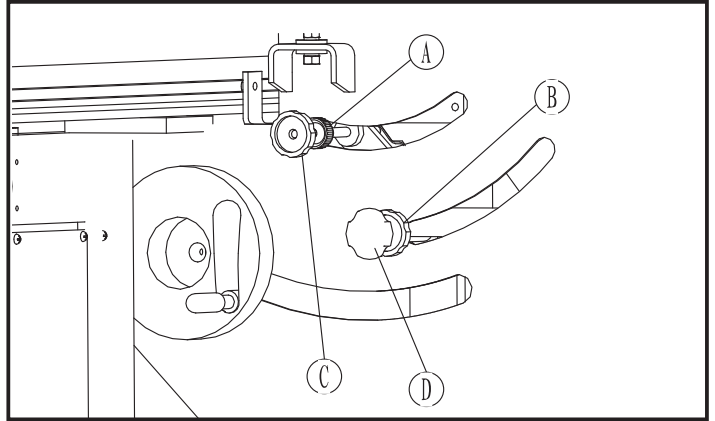
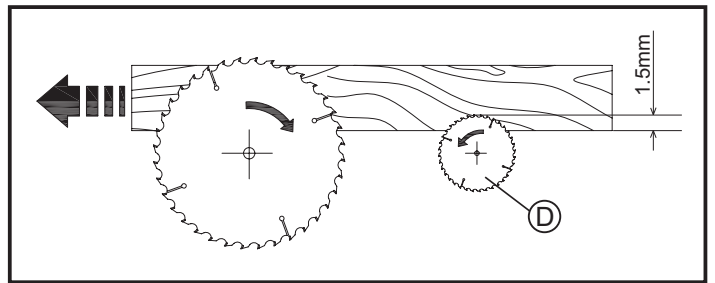

Fig.5.1

### 5.2 EXTENSION TABLE FLATNESS ADJUSTMENT

Tools Required for Assembly:

- Straight edge
  - Feeler gauge
  - L wrench 4mm
  - Wrench 16mm
- Put the straight edge B on the main table and extension tables, use feeler gauge to check the flatness.
- Re-tighten the bolts A to micro-adjust the flatness.

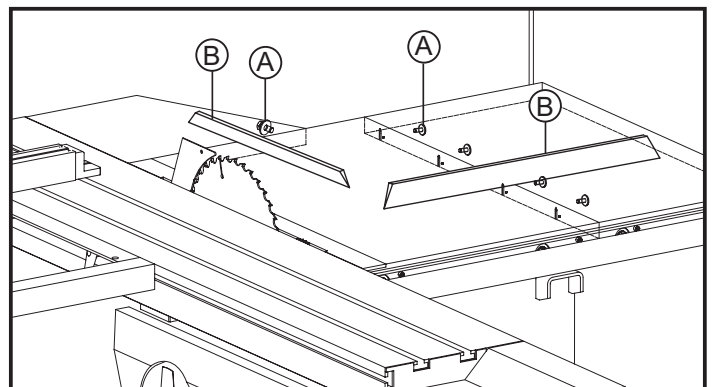

Fig.5.2

### 5.3 RIP FENCE PRECISION ADJUSTMENT

Tools Required for Assembly:

- Straight edge, Angle gauge, Depth gauge
  - Feeler gauge
  - Wrench 18mm
- Use Angle Gauge A and Feeler Gauge to check the verticality between table and rip fence. Loose 4pcs shaft B, and micro-adjust its position up and down to get better verticality.
- Use Straight Edge and Depth Gauge to check the parallel between blade and rip fence. Loose 4pcs shaft B, and micro-adjust its position forward and backward to get better parallel.

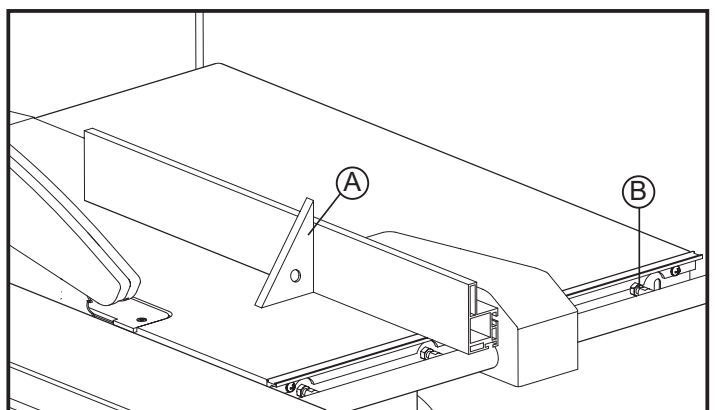

Fig.5.3

# 6. OPERATING PROCEDURES

## WARNING

Please be careful to operate the machine while saw blade is running and always DO NOT to use the machine unless all of the guards and other safety devices are in good working order.

### 6.1 MACHINE START AND STOP

The switch's position of the machine is as the picture shown.

- A is main power lamp.
- B is the button to stop main power
- C is the button to start main power and main blade running.
- D is the button to start scoring saw running.
- E is for emergency situation to turn off power absolutely.

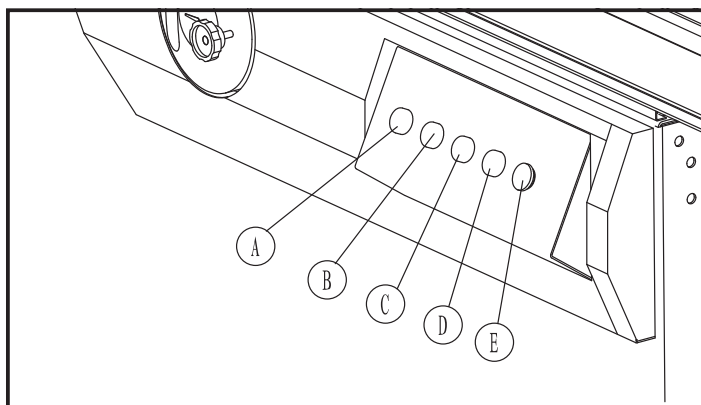

Fig.6.1

### 6.2 WORKING STATION

## WARNING

The machine has been designed to be used by one operator only. Plastic pusher shall be used when cutting small workpieces and in circumstances where it is necessary to push the workpiece against the fence.

- A - Working with the sliding table (squaring)
- B - Parallel cut side

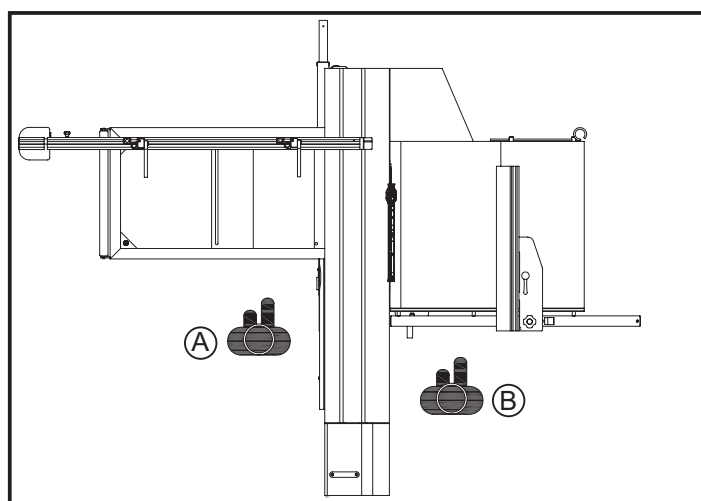

Fig.6.2

### 6.3 WORKING WITH THE MACHINE

The choice of the method to use to make a cut with the circular saw depends on the dimensions of the wood to be machined and the type of machining to be carried out. For cutting ennobled wood, use of the engraver is indispensable to prevent chipping. When the engraver is not needed, lower it completely underneath the table.

#### 6.3.1 WORKING WITH THE SLIDING TABLE

- Put workpiece on the sliding table. Fix it with the aluminium stopper B and gripping arm C.
- Stand on position A, push the operating lever which is on sliding table forward to across blade.

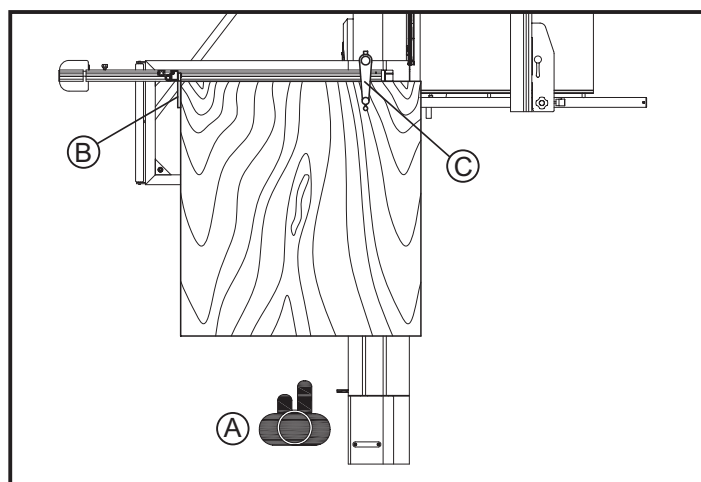

Fig.6.3.1

#### 6.3.2 WORKING WITH RIP FENCE

- Lock the sliding table. Put the workpiece against the side surface of rip fence. Push the workpiece forward across blade.
- For your safety, please use the plastic push block.
- When cutting off a small workpiece, please use the push stick to prevent accident cutting of hands.

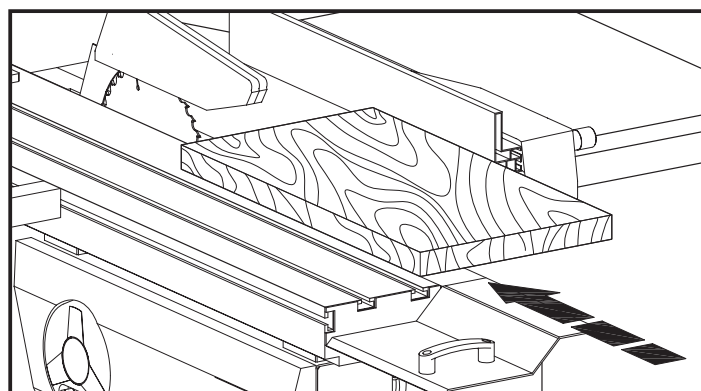

Fig.6.3.2

## 6.4 CORRECT USE FOR THIS MACHINE

- First make sure that the machine does not vibrate. Do not try to take off the material when the cut has already started; proceed with a continuous and uniform speed. Workpiece feeding towards the blade (especially where there are knots) should not be too fast (feeding speed should be in accordance with workpiece thickness). Do not let workpieces stop between the saw fence and the blade.
- Avoid contact of the tips against metallic objects. When necessary sharpen the saw blade. Often clean the steel body and the tips with proper liquid products. Let the saw blade in the bath, then clean it with brush: don't use metallic brushes. As regards the tothing at least 2-3 teeth shall cut at the same time A. If only one tooth cuts B, you don't get a good cutting. Whenever this is possible, it is also critical to lift the blade until the whole tooth cutting part protrudes from the wood thickness.



### WARNING

Before touching the machine parts, ensure to turn OFF the main switch and disconnect the general power supply.

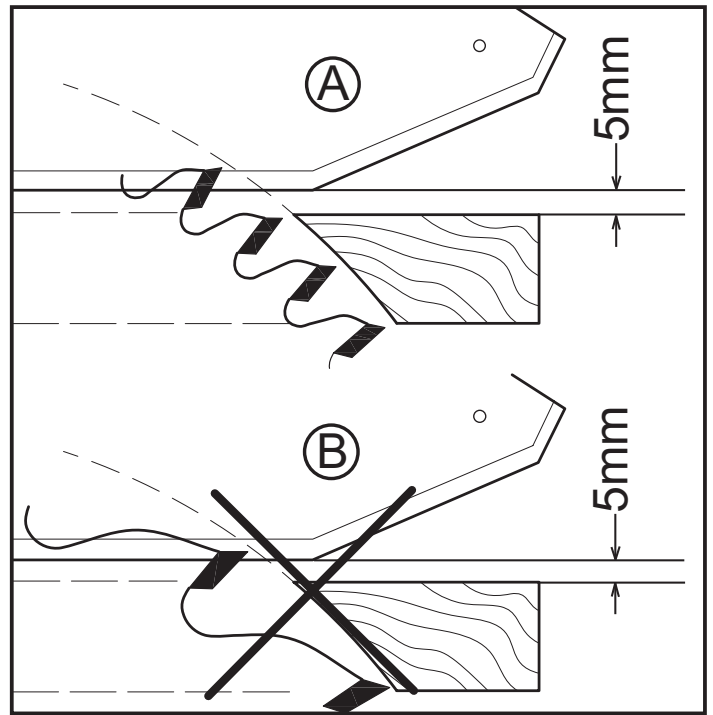

Fig.6.4

# 7. MAINTENANCE



**WARNING** Disconnect the general power supply before doing any maintenance.

## 7.1 REPLACE SAW BLADE



**WARNING**

Only correctly sharpened saw blades manufactured in accordance with the requirements of EN 847-1:2005 shall be used. Don't use the saw blade whose maximum marked speed is lower than the maximum rotational speed of the saw spindle. Please always keep the gap between the riving knife and the saw blade to be at least 3mm and not exceed 8mm.

- Rotate the blade lifting handwheel to move the blade to toppest position.
- Take out the blade guard A.
- Remove the table insert B.
- Push the sliding table to backmost position.
- Open the blade cover D.
- Unscrew the nut C to take out the blade for replacement.

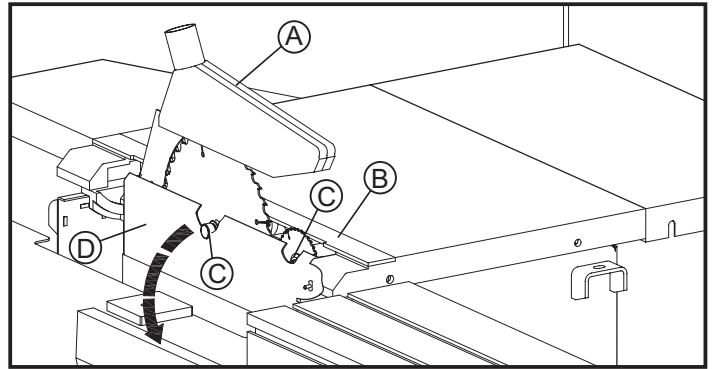

Fig.7.1

## 7.2 OVERALL CLEANING



**WARNING**

Please DO NOT to try removing chips while the saw blade is running.

After each working cycle, thoroughly clean the machine and all of its parts, vacuum the shavings and dust and remove any resin residues.

Use compressed air only when strictly necessary, using protective glasses and a mask.

In particular, clean the following parts:

- the sliding table rail A;
- the sliding support extension B;

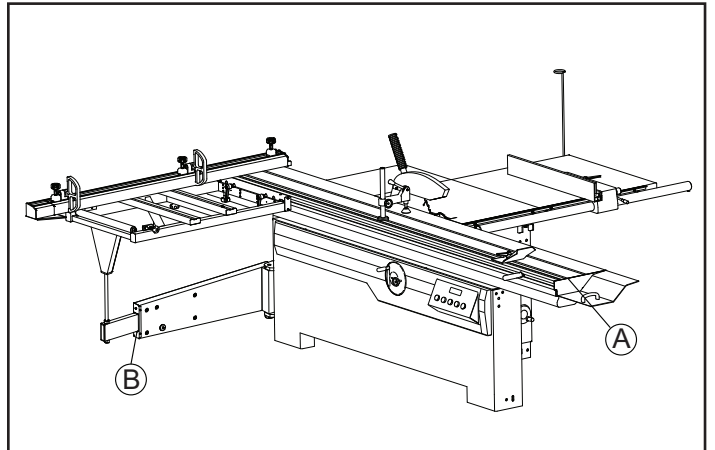

Fig.7.2

## 7.3 GENERAL LUBRICATION

- Weekly clean and lubricate all the mobile couplings of the machine A with a thin film of oil and grease.
- Protect all belts and pulleys to avoid contamination with oil.

## 7.4 REPLACEMENT AND DISPOSAL

Should replacement become necessary, the machine parts must be replaced with original components in order to guarantee their efficiency.

The replaced parts must be disposed of in compliance with the laws in force in the country of use.

Component replacement requires specific training and technical skills; for this reason, the above interventions must be carried out by qualified personnel to prevent damage to the machine and risks to the safety of persons.

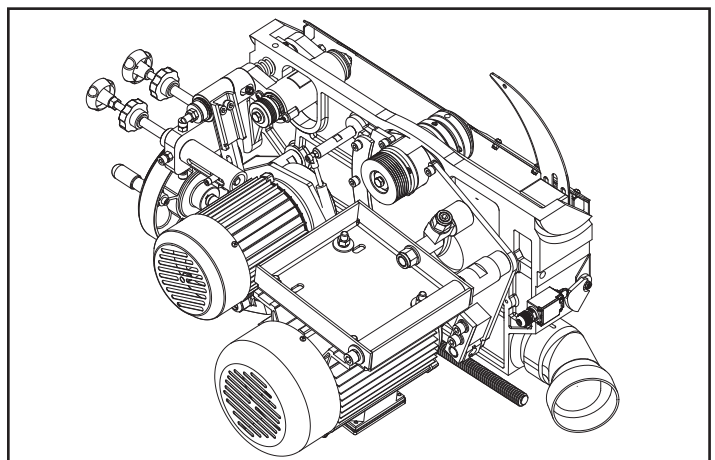

Fig.7.3



**CAUTION**

- In case of mechanical or functional faults in the machine, including guards or tools, please call the local authorized agent for technical assistance and maintenance.
- Any maintenance must be only done when the machine is isolated from all energy sources (plug out).

# 8. TROUBLE SHOOTING



## WARNING

- For any information or problem contact your area dealer or our technical service center. The necessary interventions must be carried out by specialised technical personnel.

- Before carrying out any fault service or maintenance work, please always TRUN OFF THE SWITCH, UNPLUG POWER CABLE, WAIT FOR SAW BLADE TO COME TO STANDSTILL.

Trouble	Possible Cause	Solution
Saw stops or will not start	<ol style="list-style-type: none"> <li>1. Overload tripped on motor</li> <li>2. Saw unplugged from wall or motor</li> <li>3. Fuse blown or circuit breaker tripped</li> <li>4. Cord damaged</li> </ol>	<ol style="list-style-type: none"> <li>1. Allow motor to cool and reset overload switch on motor</li> <li>2. Check all plug connections</li> <li>3. Replace fuse or reset circuit breaker</li> <li>4. Replace cord</li> </ol>
Does not make accurate 45° or 90° cuts	<ol style="list-style-type: none"> <li>1. Stops not adjusted correctly</li> <li>2. Angle pointer not set accurately</li> </ol>	<ol style="list-style-type: none"> <li>1. Check blade with square and adjust stops</li> <li>2. Check blade with square and adjust pointer</li> </ol>
Material binds blade when ripping	<ol style="list-style-type: none"> <li>1. Fence not aligned with blade</li> <li>2. Warped wood</li> <li>3. Excessive feed rate</li> <li>4. Splitter not aligned with blade</li> </ol>	<ol style="list-style-type: none"> <li>1. Check and adjust fence</li> <li>2. Select another piece of wood</li> <li>3. Reduce feed rate</li> <li>4. Align splitter with blade</li> </ol>
Saw makes unsatisfactory cuts	<ol style="list-style-type: none"> <li>1. Dull blade</li> <li>2. Blade mounted backwards</li> <li>3. Gum or pitch on blade</li> <li>4. Incorrect blade for cut</li> <li>5. Gum or pitch on table</li> </ol>	<ol style="list-style-type: none"> <li>1. Sharpen or replace blade</li> <li>2. Turn blade around</li> <li>3. Remove blade and clean</li> <li>4. Change blade to correct type</li> <li>5. Clean table</li> </ol>
Blade does not come up to speed	<ol style="list-style-type: none"> <li>1. Extension cord too light or too long</li> <li>2. Low shop voltage</li> <li>3. Motor not wired for correct voltage</li> </ol>	<ol style="list-style-type: none"> <li>1. Replace with adequate size cord</li> <li>2. Contact your local electrical company</li> <li>3. Refer to motor junction box</li> </ol>
Saw vibrates excessively	<ol style="list-style-type: none"> <li>1. Stand on uneven floor</li> <li>2. Damaged saw blade</li> <li>3. Bad V-belts</li> <li>4. Bent pulley</li> <li>5. Improper motor mounting</li> <li>6. Excessive play in raising mechanism</li> <li>7. Loose hardware</li> </ol>	<ol style="list-style-type: none"> <li>1. Reposition on flat, level surface</li> <li>2. Replace saw blade</li> <li>3. Replace V-belts</li> <li>4. Replace pulley</li> <li>5. Check and adjust motor</li> <li>6. Adjust worm and arbor bracket</li> <li>7. Tighten hardware</li> </ol>
Rip fence binds on guide rails	<ol style="list-style-type: none"> <li>1. Guide rails or extension wing not installed correctly</li> <li>2. Guide of rip fence not adjusted properly</li> </ol>	<ol style="list-style-type: none"> <li>1. Reassemble guide rails, refer to fence manual</li> <li>2. Adjust guides, refer to fence manual</li> </ol>
Material kicked back from blade	<ol style="list-style-type: none"> <li>1. Rip fence out of alignment</li> <li>2. Splitter not aligned with blade</li> <li>3. Feeding stock without rip fence</li> <li>4. Splitter not in place</li> <li>5. Dull blade</li> <li>6. Letting go of material before it is past blade</li> <li>7. Anti-kick back plates dull</li> </ol>	<ol style="list-style-type: none"> <li>1. Align rip fence with miter slot</li> <li>2. Align splitter with blade</li> <li>3. Install and use rip fence</li> <li>4. Install and use splitter (with guard)</li> <li>5. Replace blade</li> <li>6. Push material all the way past blade before releasing work</li> <li>7. Replace or sharpen anti-kick back plates</li> </ol>
Blade does not raise or tilt freely	<ol style="list-style-type: none"> <li>1. Too much tension in raising mechanism</li> <li>2. Sawdust and debris in raising and tilting mechanisms</li> </ol>	<ol style="list-style-type: none"> <li>1. Adjust raising worm and arbor bracket</li> <li>2. Clean and regrease</li> </ol>

# 9. DIAGRAMS & COMPONENTS

## Frame Assembly

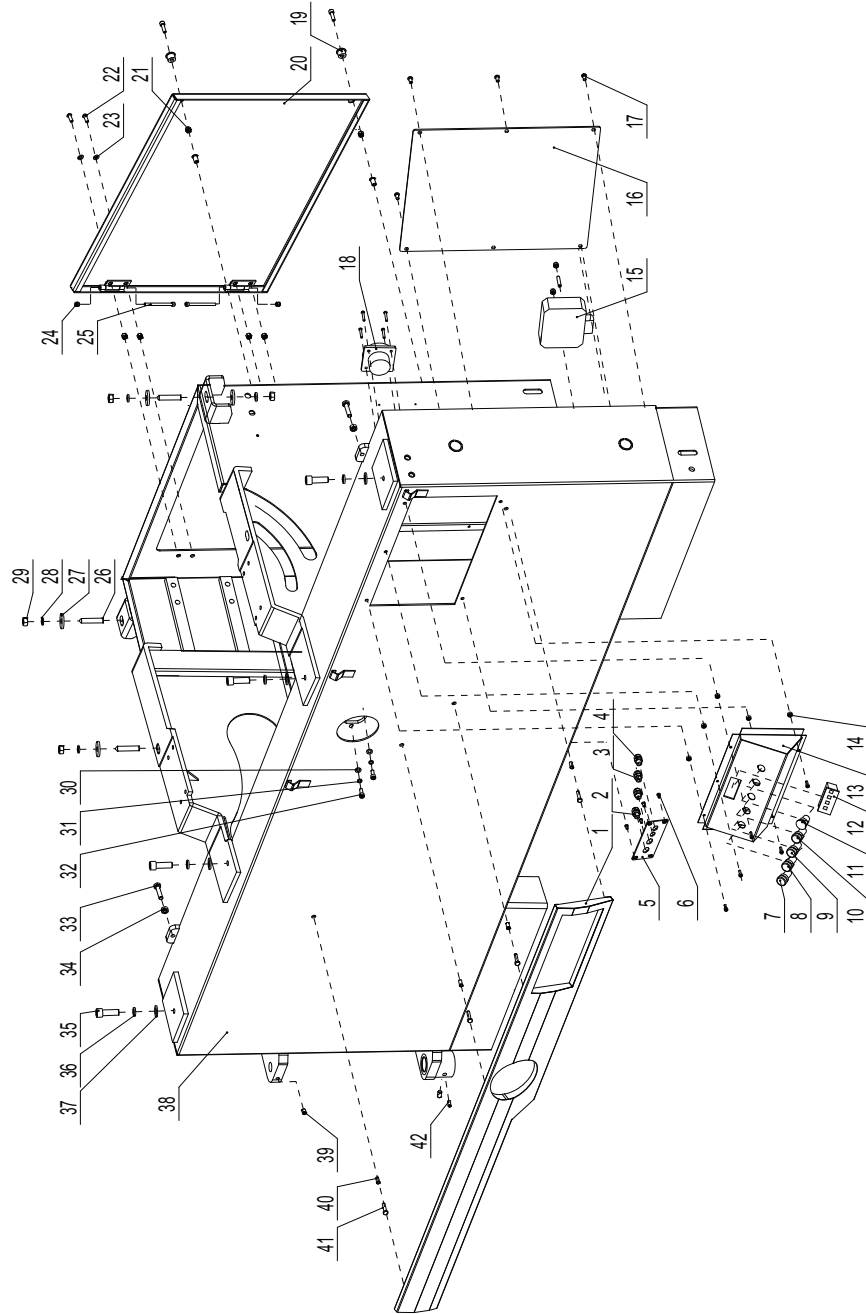

No.	Description	Part No.	Qty.
1	Iron tcover	JXPS1204012000C	1
2	Strain relief	JXSM0401010004	1
3	Strain relief	JXSM0401010003	2
4	Clip	7N-2	1
5	Threading plate	JXPS1201010016A	1
6	Screw M5	M5X12GB70D2Z	4
7	Power lamp	AD16	1
8	Button	LA39	1
9	Button	LA39-D	1
10	Button	LA39-D	1
11	Emergency switch Button	LA42	1
12	Digital readout	M30A	1
13	switch plate	JXPS1201011400A	1
14	Nut	M6GB6170Z	5
15	Wiring box assy	JXPS1201090009	1
16	Cover plate	JXPS1201010001A-060U	1
17	Screw M6	M6X12GB70D2Z	6
18	Switch	ZH-HD-2-01	1
19	Bolt sleeve	JXTH2501011028	2
20	Rear door plate	JXPS1201010002C-1	1
21	Lock nut M6	M6GB889D1Z	6
22	Screw M6	M6X16GB70D2Z	4
23	Flat washer	WSH66GB97D1Z	4
24	Lock nut M5	M5GB889D1Z	4
25	Screw M5	M5X70GB70D1B	2
26	Set screw M12	M12X100GB70B	4
27	Washer	SCPS1601061010	8
28	Spring washer	WSH12GB93Z	8
29	Nut M12	M12GB6170Z	12
30	Flat washer	WSH66GB97D1Z	3
31	Spring washer	WSH66GB93B	3
32	Screw M6	M6X16GB70Z	3
33	Bolt M10	M10X50GB5781Z	2
34	Nut M10	M10GB6170Z	2
35	Screw M12	M12X35GB70B	4
36	Spring washer	WSH12GB93B	4
37	Flat washer	WSH12GB97D1B	4
38	Frame assy	JXPS1201011000AA	1
39	Set screw M8	M8X12GB78B	1
40	Rivet nut M6	M6X16D5GB17880D3Z	9
41	Bolt M6	M6X16GB5789Z	4
42	Set screw M10	M10X25GB77B	3

# Spindle Assembly

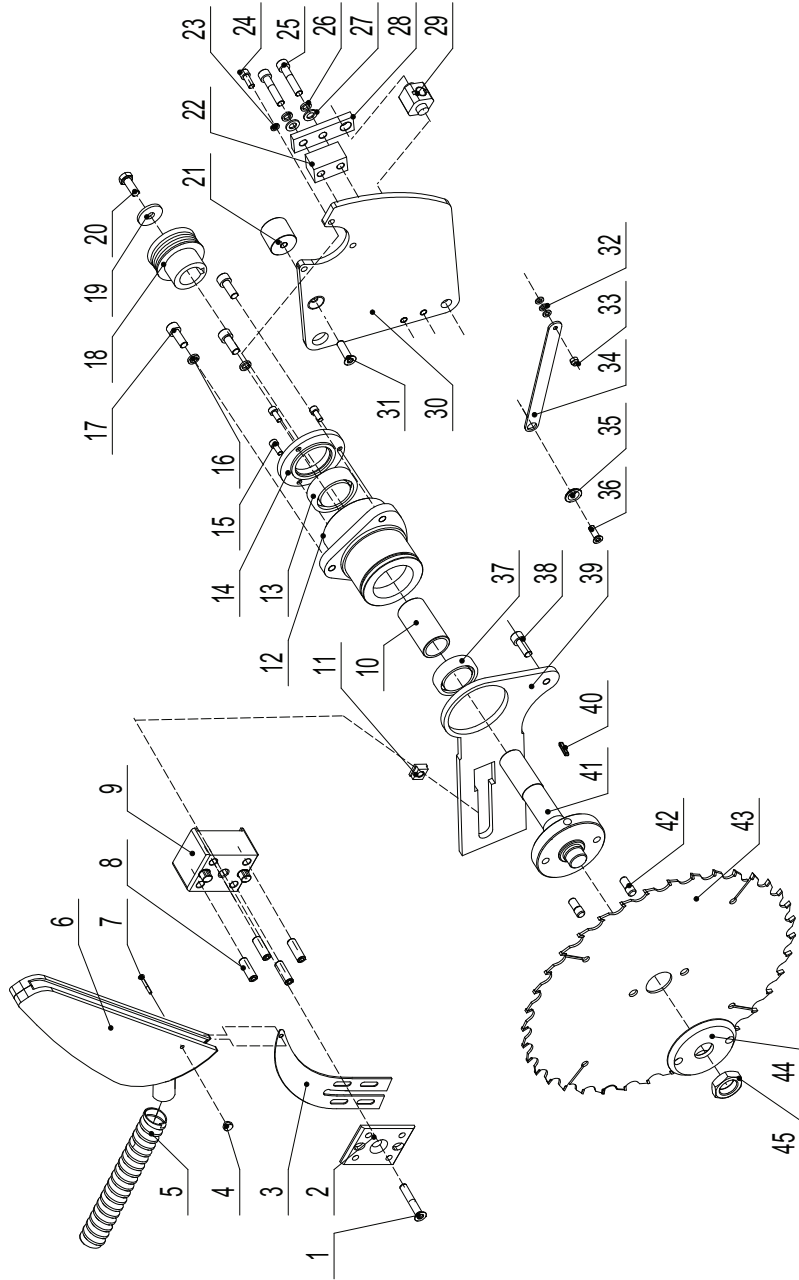

No.	Description	Part No.	Qty.
1	Screw	N10X55GB70D3Z	1
2	Lock plate	JXPS1201028008A	1
3	Riving Plate	JXPS1201028001A	1
4	Self-locking nut M6	M6GB889Z	1
5	Dust hose	JXTS1202020018	1
6	Blade guard assy	JXTS1201027000	1
7	Screw	M6X30GB70D3Z	1
8	Set screw	M8X25GB77B	4
9	Adjustable plate	JXPS1201028007A	1
10	Tube	JXPS1201021007	1
11	Lock bracket	JXPS1201028005	1
12	Shaft seat	JXPS1201021006C	1
13	Bearing	BRG6205-DDU	1
14	Plate	JXPS1201021010	1
15	Screw M5	M5X12GB70Z	3
16	Spring washer	WSH8GB93Z	3
17	Screw M8	M8X20GB70Z	3
18	Spindle pulley	JXPS1201021009C	1
19	Big washer	WSH8GB5287Z	1
20	Hex bolt	M8X20GB5783Z	1
21	Shaft	JXPS1201020009	1
22	Bracket	JXPS1201025007	1
23	Spring washer	WSH8GB90Z	3
24	Screw M8	M8X20GB70Z	2
25	Screw M8	M8X30GB70Z	3
26	Spring washer	WSH8GB93Z	3
27	Flat washer	WSH8GB97D1Z	3
28	Pressing plate	JXPS1201025008	1
29	Lifting nut	JXPS1201025009	1
30	Lifting plate	JXPS1201021008A	1
31	Screw M10	M10X25GB70D3Z	1
32	Flat washer	WSH6GB97D1Z	3
33	Self-locking nut M6	M6GB889Z	1
34	Connecting rod	JXPS1201028004	1
35	Tube	JMTS1001024006	1
36	Screw M6	M6X20GB70D3Z	1
37	Bearing	BRG6005-ZZGB276	1
38	Screw M6	M6X20GB819Z	1
39	Riving plate seat	JXPS1201028002	1
40	flat key	PLN8X7X20GB1096	1
41	Spindle	JXPS1201021005	1
42	Pin	JXPS1201021003	2
43	Main blade	JXPS1201021004	1
44	Blade flange	JXPS1201021002	1
45	Lock nut	JXPS1201021001	1

# Lift & tilt Handwheel Assembly

No.	Description	Part No.	QTY.
1	Lock handle	JXPS1201026010-001S	1
2	Screw	M8X12GB70D2Z	1
3	Washer	JXPS1201026012	1
4	Tilting handwheel	JXPS1602027020	1
4	Tilting handwheel	JXPS1201026006-001S	1
5	Screw	M6X6GB77B	1
6	Screw	M6X20GB70Z	2
7	Washer	WSH6GB96Z	2
8	Shaft	FDPS1201026008	2
9	Tube	JXPS1201026009	1
10	Bearing	BRG51101GB301	2
11	Threaded rod	JXPS1201025006	1
12	Pin	PIN5X24GB879D1B	2
13	Gimbal	JXPS1201025100	1
14	Gasket	JL91010016	1
15	Nut	JXPS1201025010	1
16	Threaded rod	JXPS1201026004A	1
17	Limit nut	JXPS1201026011B	1
18	Screw	M6X8GB80B	2
19	Flat washer	WSH8GB97D1Z	3
20	Spring washer	WSH8GB93Z	3
21	Flat washer	M8X30GB70Z	3
22	Handle bolt	JL84032003	1
23	Handle	JL84032002-001S	1
24	Cover	JXPT1201040019-001S	1
25	Hex nut	M10GB6170Z	1
26	Lifting handwheel	JXPT1201040018-001S	1
27	Shaft	JXPS1201025001C	1
28	Set screw	M8X12GB78B	1
29	Tube	JXPS1201025003	1
30	Set screw	M6X6GB78B	2
31	Thrust needle	BRG1730AXKASGB4605	1
32	Lifting bracket	JXPS1201025005B	1
33	Tube	P19X17X15GB12613	2
34	Set screw	M6X6GB77B	2

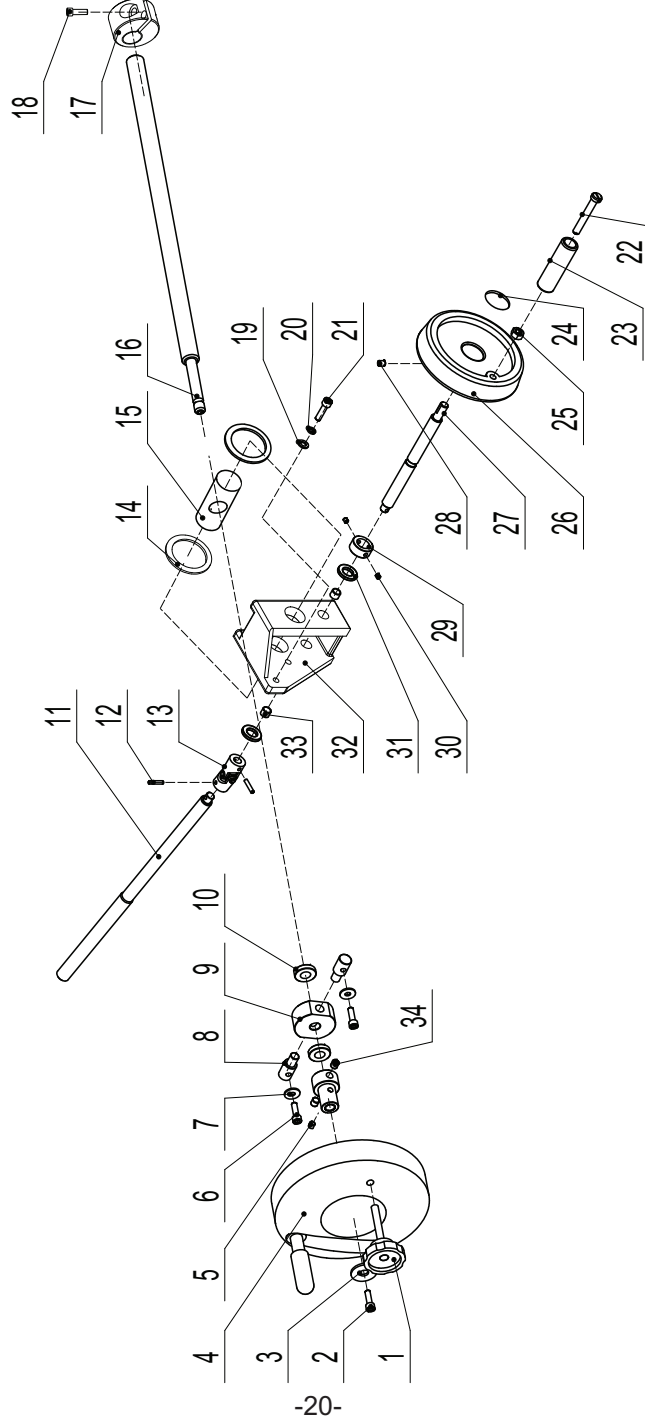

# Main Motor Assembly

No.	Description	Part No.	Qty.
1	Poly V-belt	6PK675GB16588	1
2	Washer	JXPS1202070005	1
3	Motor wheel (400V/50Hz)	JXPS1201023001N	1
	Motor wheel (230V/50Hz)	JXPS1201023001P	1
	Motor wheel (400V/60Hz)	JXPS1201023001Q	1
	Motor wheel (230V/60Hz)	JXPS1201023001S	1
4	Flat key	PLN8X7X20GB1096	1
5	Motor (400V)	YSA105402/A	1
	Motor (230V)	YYA900302B	1
6	Hexagon bolt M10	M10X35GB5783Z	4
7	Flat washer	WSH10GB97D1Z	4
8	Spring washer	WSH10GB93Z	4
9	Hex nut M10	M10GB6170Z	8
10	Screw M12	M12X20GB70Z	1
11	Spring washer	WSH12GB93Z	1
12	Big washer	WSH12GB96Z	1
13	Motor base	JXPS1201023002C	1
14	Shaft	JXPS1201020006B	1
15	Self-locking nut M16	M16B889Z	1
16	Flat washer	M16GB97D1Z	1
17	Tension block	JXPS1201023004B	1
18	Screw	JXPS1201023006B	1
19	Adjusting nut	JXPS1201023005	1
20	Flat washer	WSH16GB97D1Z	1
21	Hexagon lock nut M16	M16GB889D1Z	1
22	Spring washer	WSH8GB93Z	1
23	Screw	JL820800003	1

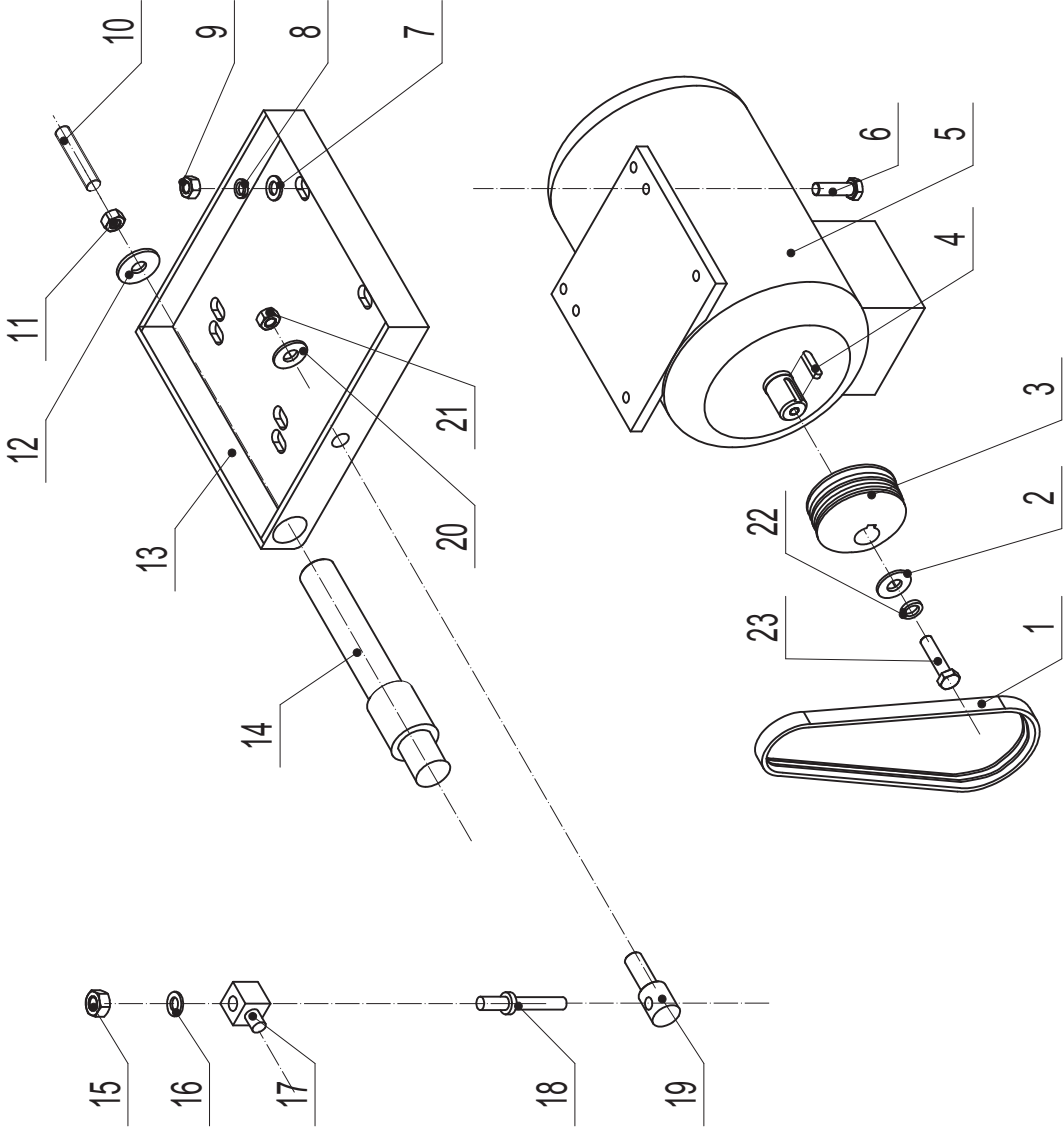

# Inside Assembly

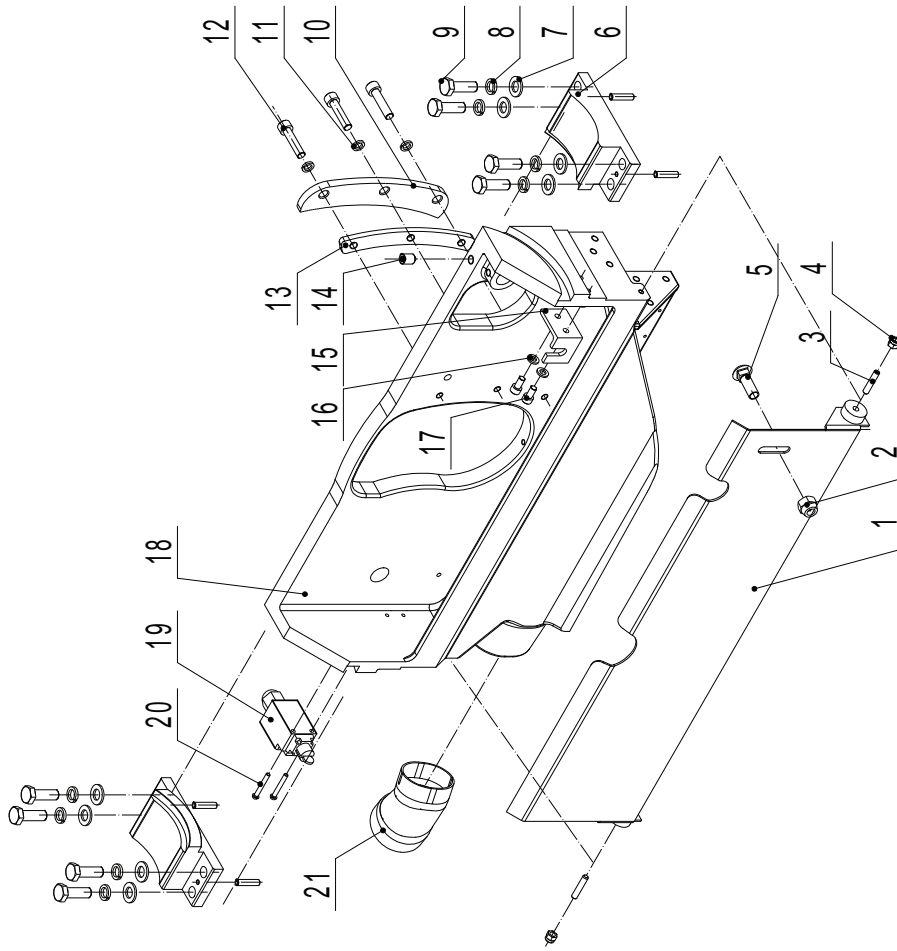

No.	Description	Part No.	Qty.
1	Blade guard	JXPS1201020100	1
2	Self-locking nut	M8GB889Z	1
3	Screw M6	M6X20GB77B	2
4	Lock nut M6	M6GB889D1Z	2
5	Bolt M8	M8X25GB12Z	1
6	Rotary bearing seat	JXPS1201020002E	2
7	Flat washer	WSH10GB97D1Z	4
8	Spring washer	WSH10GB93Z	4
9	Hexagon bolt M10	M10X30GB5783Z	5
10	Pressing plate	JXPS1201020008	1
11	Spring washer	WSH8GB93Z	3
12	Screw M8	M8X35GB70Z	3
13	Clapboard	JXPS1201020007A	1
14	Screw M10	M10X16GB78B	1
15	L plate	JMTS1001020004	1
16	Flat washer	WSH6GB97D1Z	2
17	Screw M6	M6X12GB70Z	2
18	Frame	JXPS1201020001B	1
19	Safety switch	QKS7-01	1
20	Screw M4	M4X30GB818Z	2

# Scoring Shaft seat Assembly

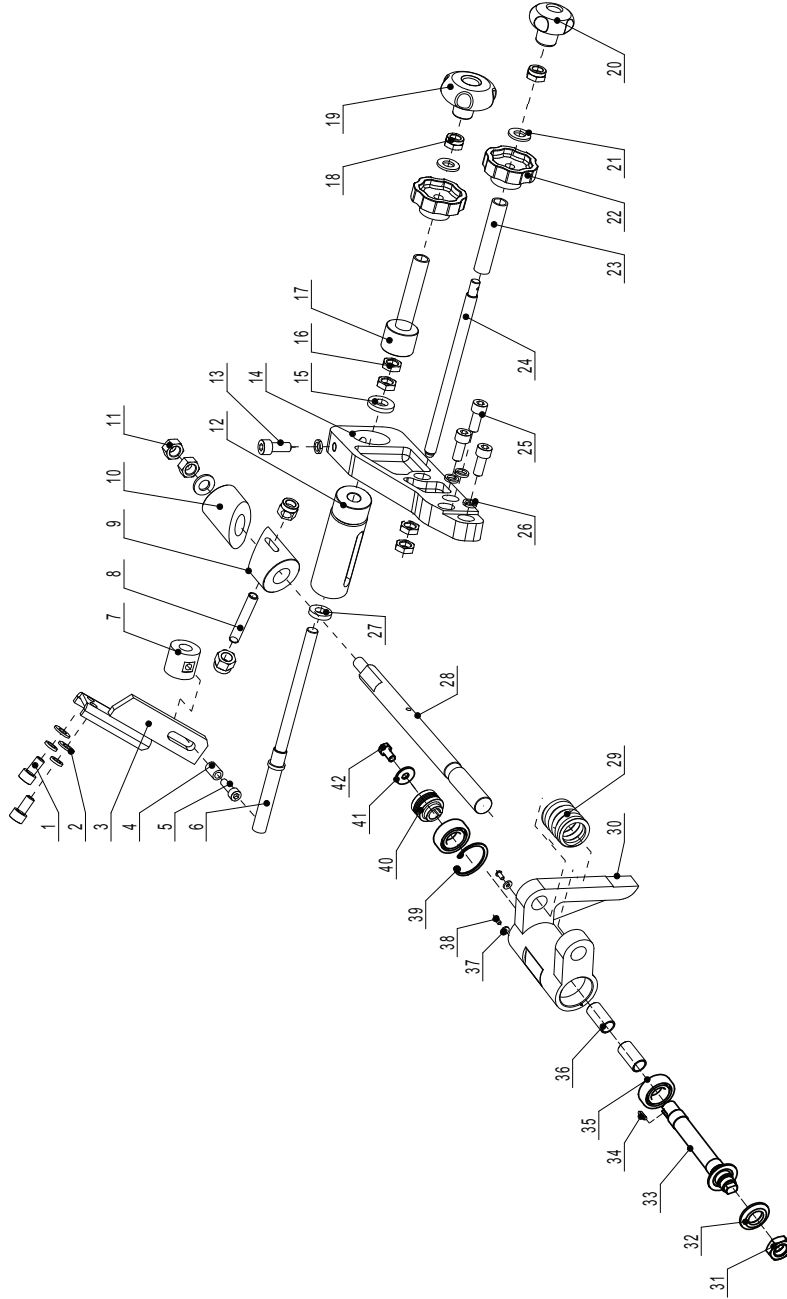

No.	Description	Part No.	Qty.
1	Screw M8	M8X25GB70D1Z	2
2	Spring washer	WSH8GB93Z	2
3	Adjust plate	JXPS1201027005B	1
4	Sliding sleeve	JXPS1201027008	2
5	Screw M6	M6X20GB70D1Z	2
6	Adjusting rod	JXPS1201027004C	1
7	Adjusting nut	JXPS1602028011	1
8	Stud	JXPS1201027015	1
9	Adjusting wedge 1	JXPS1201027013A	1
10	Adjusting wedge 2	JXPS1201027014A	1
11	Hexagon thin nut M10	M10GB6172D1Z	2
12	Sleeve	JXPS1201027006C	1
13	Screw M8	M8X25GB70D1Z	3
14	Scoring adjust seat	JXPS1201027002G	1
15	washer	WSH10GB97D1Z	1
16	Hexagon thin nut M10	M10GB6172D1Z	2
17	Casing pipe assy	JXPS1201027001E	1
18	Hex nut M10	M10GB6170Z	1
19	Round handle M10	JXPS1203025004	1
20	Round handle	JL50064002	1
21	Nut M10	M10GB6172D1Z	2
22	Lock wheel	JXTS1201028004	2
23	Tube	JXPS1201027001D	1
24	Handle lever	JXPS1602028101	1
25	Screw M8	M8X30GB70D1Z	3
26	Spring washer	WSH8GB93Z	3
27	Thrust bearing	BRG1226AXKASGB4605	1
28	Support shaft	JXPS1201022017B	1
29	Pressure spring	JXPS1201027009B	1
30	Scoring shaft seat	JXPS1201022005C	1
31	Hexagon thin nut M18	M18GB6173Z	1
32	Scoring blade flange	JXPS1201022002	1
33	Scoring shaft	JXPS1201022004C	1
34	flat key	PLN6X6X25GB1096	1
35	Deep groove ball bearing	BRG6004-2NSE	2
36	Sleeve	JXPS1201022008A	2
37	Washer	JXBS1603010003	2
38	Screw M6	M6X12GB70D2Z	2
39	Circlip	CLP42GB893D1B	1
40	Scoring spindle pulley	JXPS1201022009C	1
41	Big washer	WSH8GB96D1Z	1
42	Screw	JL82080003	1



# Table Assembly

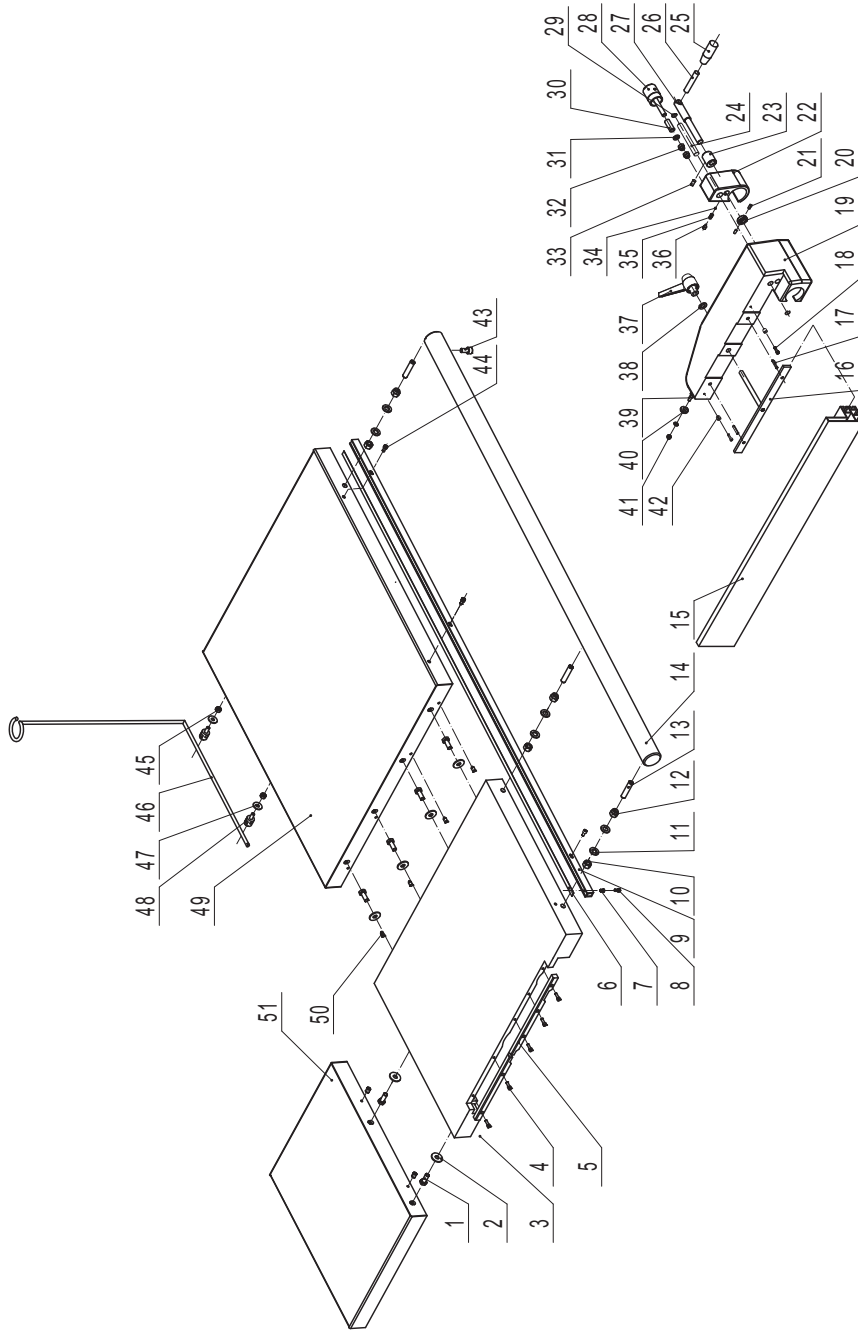

No.	Description	Part No.	QTY.
1	Bolt	M10x25GB5783Z	6
2	Flat washer	WSH10GB96Z	6
3	Main table	JXPS1201030001D	1
4	Screw	M5x16GB70Z	5
5	Table insert	JXPS1201030002	1
6	Scale	SCPS1601060003	1
7	Nut	M6X15GB/T17880D3Z	1
8	Screw	M6X20GB70D1Z	1
9	Bracket	JXPS1201060002D	1
10	Hex nut	M16GB6170Z	3
11	Flat washer	WSH16GB97D1Z	6
12	Nut	M16GB889D1Z	3
13	Screw	JXPS1201060006	3
14	Guide rail	JXPS1201060001B	1
15	L shaped rip fence	JXPS1201060004A	1
16	Lock plate	JXPS1201061006B	1
17	Roll pin	PIN6X26GB879B	2
18	Screw	M5X20GB70Z	2
19	Fence seat	JXPS1201061001A	1
20	Ring	JXPS1201061011	1
21	Lock screw	M4X6GB77B	2
22	Micro adjustment bracket	JXPS1201061002A	1
23	Eccentric bushing	JXPS1201061013	1
24	Shaft	JXPS1201061012	1
25	Handle groove	JXPT1201020007-001S	1
26	lock rod	GRPS1401061001	1
27	lock handle rod	JXPS1201061014	1
28	Micro adjustment handle	JXPS1201061010-001S	1
29	Ring	CLP14GB893D1B	2
30	Tube	JXPS1201061015	2
31	Flat washer	WSH8GB97D1Z	2
32	Nut	M8GB6172Z	2
33	screw	M6X12GB78B	1
34	Steel ball	6D5G10GB/T308	1
35	Spring	JXPS1203023009	1
36	Screw	M8X16GB77B	1
37	Adjustable handle	KTSB-1-A-M10X80	1
38	Flat washer	WSH10GB97D1Z	1
39	Eccentric shaft	JXPS1201061004	1
40	Wheel	JXPS1201061005A	1
41	Nut	M8GB6170Z	1
42	Tube	JXPS1602061006	2
43	Set screw	M5X10GB70Z	1
44	Set screw	M6X12GB70D2Z	4
45	Hex nut	M8GB6170Z	2
46	Hose Bracket	JXTS1201050003	1
47	Big washer	WSH8GB96Z	2
48	Bracket block	JXPS1201050004	2
49	Right Table Extension	JXPS1201030003D	1
50	screw	M8X10GB77B	8
51	Rear Table Extension	JXPS1201030004C	1

# Sliding Table Assembly

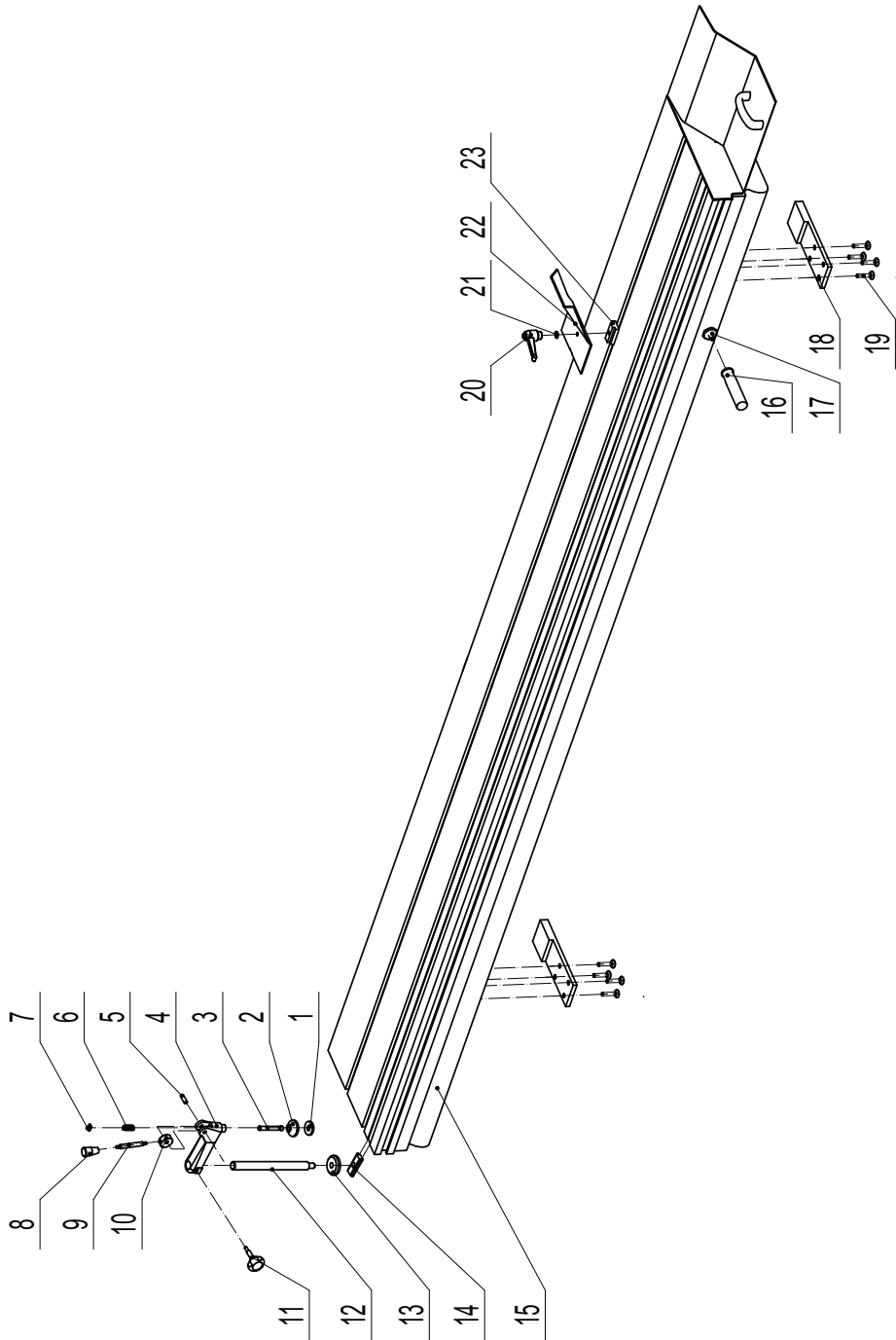

No.	Description	Part No.	QTY.
1	Rubber feet	JXSM0401042108	1
2	Plate	JXSM0401042107-001S	1
3	Rod	JXSM0401042106	1
4	Rod	JXSM0401042101	1
5	Shaft	JXSM0401042103	1
6	Spring	JXSM0401042105	1
7	Retaining ring	CLP12GB894D1B	1
8	Handle groove	JXPT1201020007-001S	1
9	Handle rod	JXSM0401042104	1
10	Cam	JXSM0401042102	1
11	Round handle	JXSM0401083002-001S	1
12	Rod	JXSM0401042003	1
13	Plate	JXSM0401042001	1
14	Slide bracket	JXSM0401042002	1
15	Slide table	JXPS1201041000A	1
16	Handle	JXPS1201040002	1
17	Hex slider	JXPS1201040001	1
18	Slide table plate	JXPS1201040009	2
19	Set screw	M6X16GB70D3B	8
20	Lock handle	JXCM2501012100-001S	1
21	Flat washer	WSH8GB97D1Z	1
22	Plate	JXPS1201040003	1
23	Slider	JXPS1201040004	1

# Square Sliding Table Assembly

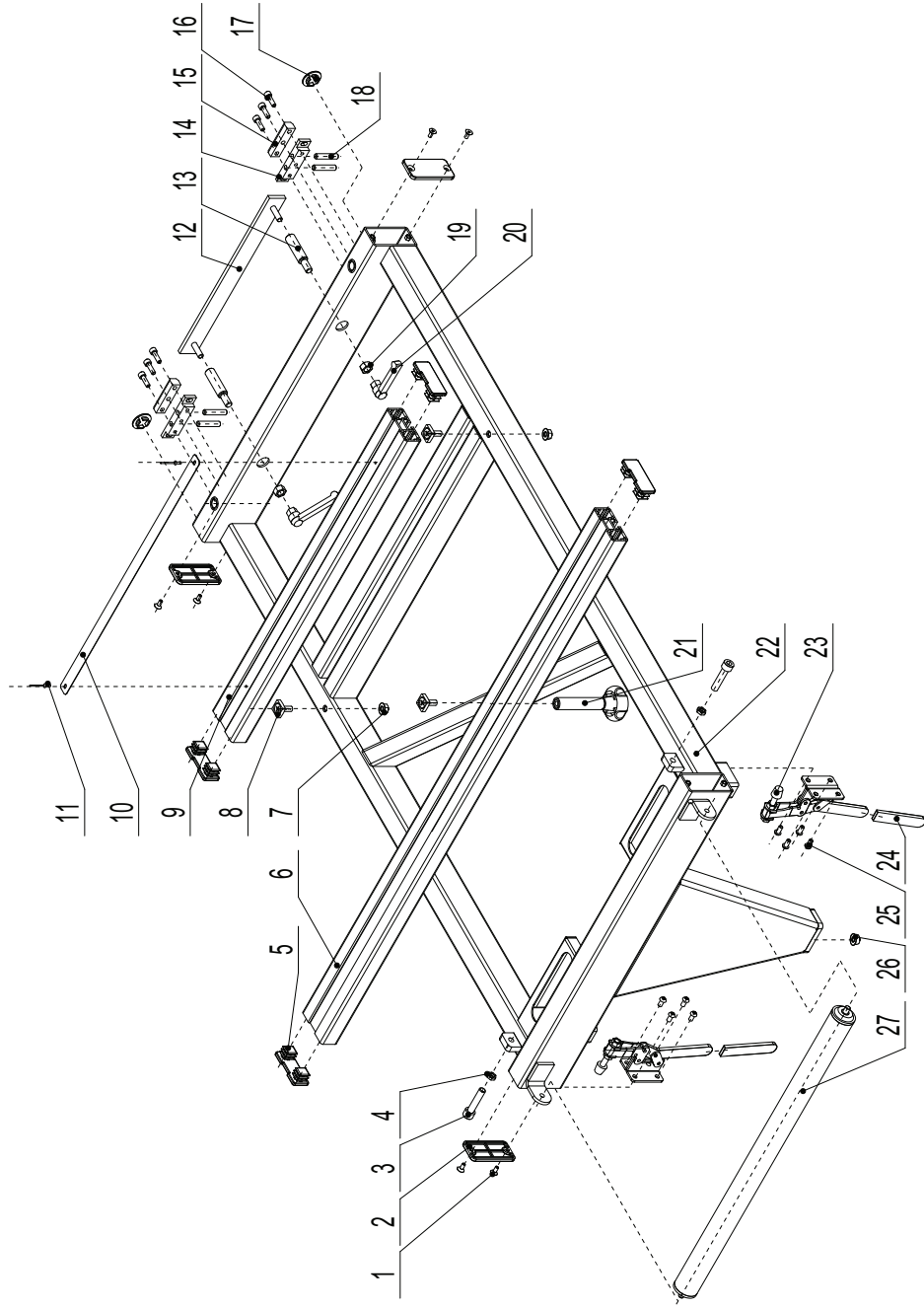

No.	Description	Part No.	QTY.
1	Screw	M5X12GB70D3B	8
2	End cap	JXPS1201051014	4
3	Screw	M10X45GB70Z	2
4	Nut	M10GB6172Z	2
5	End cap	GRPS1401051003	4
6	Long plate	JXPS1201051011A	1
7	Nut	M8GB6177D1Z	2
8	lock block	JL84100003	3
9	Scale plate	JXPS1201051012	1
10	Angle gauge	JXPS1201051003B	1
11	rivet	RVT3X7GB12618A	2
12	Lock plate	JXPS1201051002	1
13	Lock shaft	JXPS1201051201	2
14	lock block	JXPS1201051016	2
15	Guide block	JXPS1201051015A	2
16	Screw	M6X20GB70Z	6
17	Mat	JXPS1201051010	2
18	Screw	M8X40GB77B	4
19	Nut	M10GB6170Z	2
20	Adjustable handle	KTSB-1-A-M10X80	2
21	lock handle	JL84102000	1
22	Slide bracket assy	JXPS1201051100F	1
23	Tool holder	JXPS1201051006	2
24	Tool holder tube	JXPS1201051007-001S	2
25	Screw	M6X16GB70D2Z	8
26	tube	P12X10X8-AGB12613	1
27	roller	SCPS1601051010	1

# Support Bracket Assembly

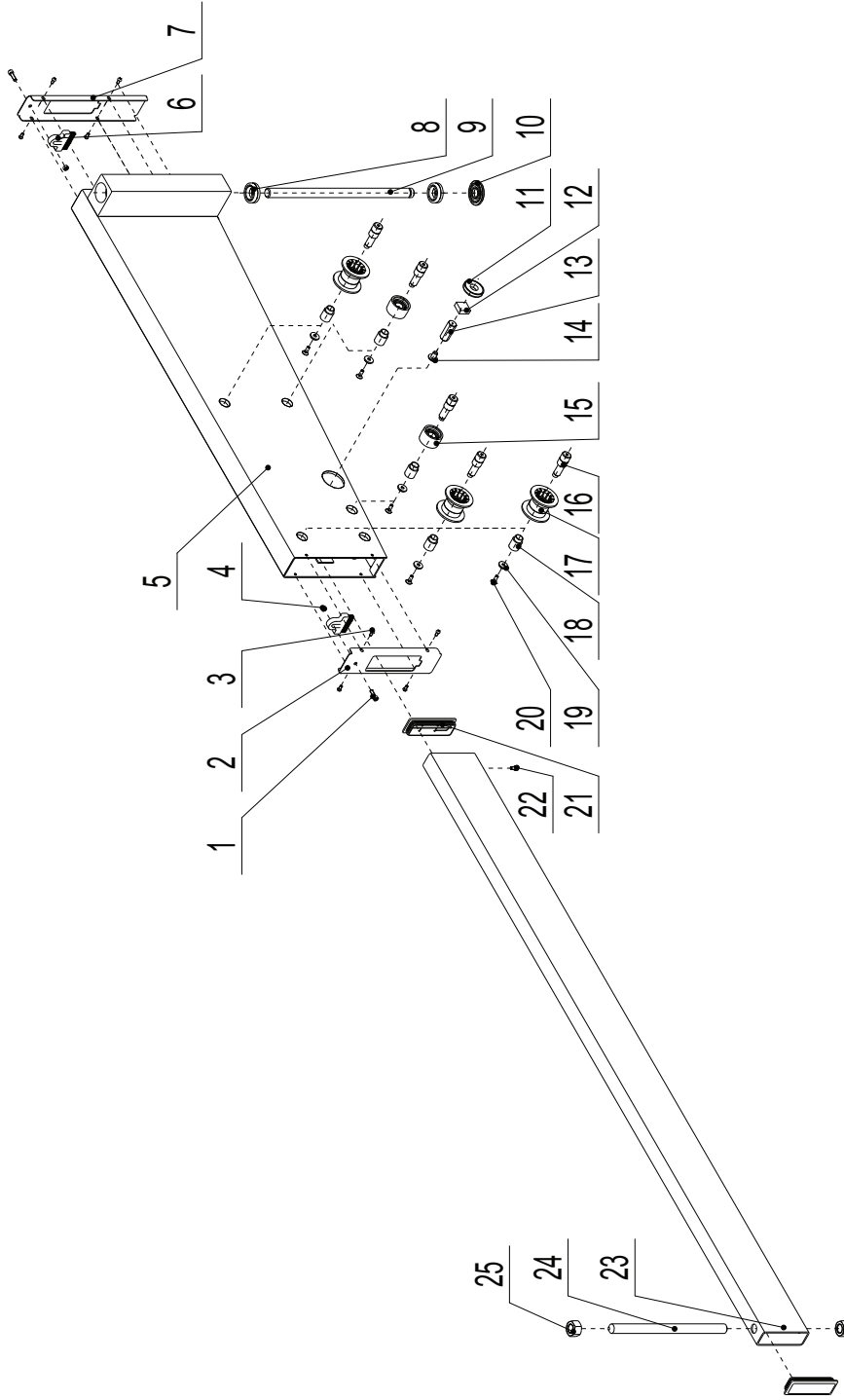

No.	Description	Part No.	QTY.
1	Screw	M6X20GB70D2Z	2
2	Cover	JXPS1602052005	1
3	Screw	M5X10GB818Z	8
4	Hex nut	M6GB6170Z	2
5	Support bracket	JXPS1602052003B	1
6	Brush	JXTS1201052005	2
7	Cover	JXPS1602052006	1
8	Bearing	BRG6004-2RZ	2
9	Shaft	JXPS1201052005B	1
10	Washer	JXPS1201052006A	1
11	Magnet	SCPS1601052014	1
12	Sponge	SCPS1601052020	1
13	Hexagonal prism	SCPS1601052016	1
14	Screw	SCPS1601052015	1
15	Bearings rolling wheel	SCPS1601052007	2
16	Eccentric shaft	SCPS1601052004	5
17	Bearings rolling wheel	SCPS1601052019	3
18	Position tube	JXPS1602052205A	5
19	Washer	JXPS1602052206	5
20	Screw	M6X16GB70D3Z	5
21	Plastic end-cap	JXPS1602052008	2
22	Screw	M6X10GB70Z	1
23	Telescopic arm	JXPS1602052004	1
24	Telescopic arm	JXPS1602052004A	1
25	Hex nut	M20x1D5GB6173Z	2
25	Support rod	JXPS1201052001B	1

# Telescopic Fence Assembly

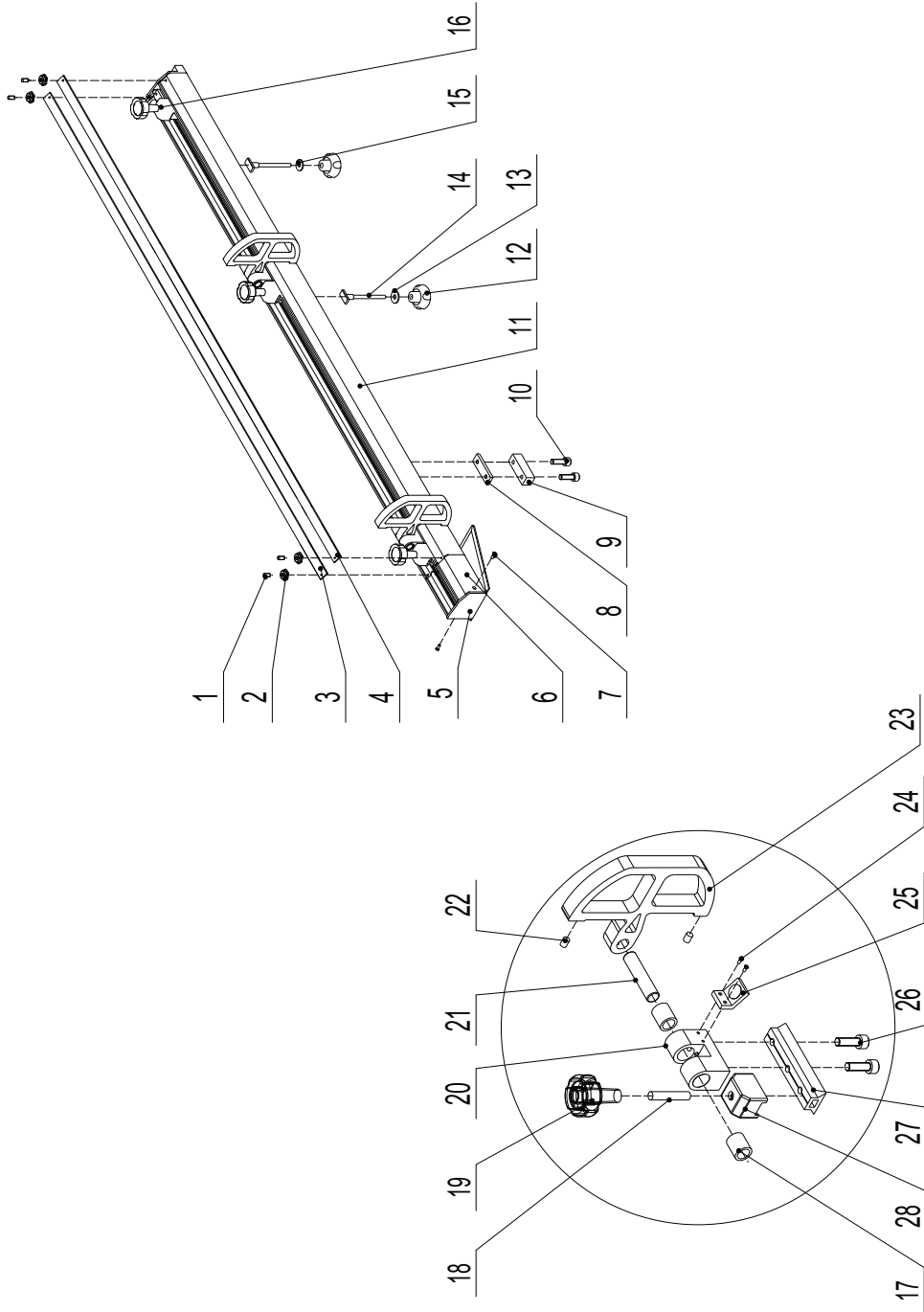

No.	Description	Part No.	QTY
1	Screw	M5X4GB80B	4
2	Lock slider	JXPS1201053009	4
3	Scale	JXPS1201053006C	1
4	Scale	JXPS1201053006D	1
5	End cap	JXPS1201053105A	1
6	Bracket	JXPS1201053101	1
7	Screw	ST4D2X13GB846Z	2
8	Slider	JXPS1201053005H	1
9	Position bracket	JXPS1201053007A	1
10	Screw	M8X25GB70Z	2
11	Bracket	JXPS1201053102	1
12	Handle	JXTS1201131001-001S	2
13	Washer	WSH8GB5287Z	1
14	Slider	JXPS1201053005D	2
15	Washer	WSH8GB96Z	1
16	Scale bracket	JXPS1201053120	1
17	Tube	JXPS1201053118	4
18	Double-end bolt	M10X70GB/T889B	2
19	Lock button	JXPS1201053111	2
20	Position block	JXPS1201053114	2
21	Shaft	JXPS1201053116	1
22	Plastic screw	M8X20GB73S	4
23	Bracket	JXPS1201053104	2
24	Screw	M4X6GB819Z	4
25	Lens	JXPS1201053115	1
26	Screw	M8X12GB70Z	4
27	Guide block	JXPS1201053117	1
28	Lock press block	JXPS1201053112	2